

# **SC-R5000 Series**

# **SC-R5000L Series**

# **User's Guide**

---

---

## Copyrights and Trademarks

---

### **Copyrights and Trademarks**

No part of this publication may be reproduced, stored in a retrieval system, or transmitted in any form or by any means, electronic, mechanical, photocopying, recording, or otherwise, without the prior written permission of Seiko Epson Corporation. The information contained herein is designed only for use with this Epson printer. Epson is not responsible for any use of this information as applied to other printers.

Neither Seiko Epson Corporation nor its affiliates shall be liable to the purchaser of this product or third parties for damages, losses, costs, or expenses incurred by the purchaser or third parties as a result of accident, misuse, or abuse of this product or unauthorized modifications, repairs, or alterations to this product, or (excluding the U.S.) failure to strictly comply with Seiko Epson Corporation's operating and maintenance instructions.

Seiko Epson Corporation shall not be liable for any damages or problems arising from the use of any options or any consumable products other than those designated as Original Epson Products or Epson Approved Products by Seiko Epson Corporation.

Seiko Epson Corporation shall not be held liable for any damage resulting from electromagnetic interference that occurs from the use of any interface cables other than those designated as Epson Approved Products by Seiko Epson Corporation.

EPSON and EPSON EXCEED YOUR VISION or EXCEED YOUR VISION and their logos are registered trademarks or trademarks of Seiko Epson Corporation.

Microsoft®, Windows®, and Windows Vista® are registered trademarks of Microsoft Corporation.

Mac, macOS are registered trademarks of Apple Inc.

Intel® is a registered trademark of Intel Corporation.

Adobe and Reader are either registered trademarks of Adobe in the United States and/or other countries.

Bemcot™ is a trademark of Asahi Kasei Corporation.

YouTube® and the YouTube logo are registered trademarks or trademarks of YouTube, LLC.

*General Notice: Other product names used herein are for identification purposes only and may be trademarks of their respective owners. Epson disclaims any and all rights in those marks.*

© 2020 Seiko Epson Corporation

## **Note for North American and Latin American Users**

**IMPORTANT:** Before using this product, make sure you read the safety instructions in the online *Notices*.

**Contents**

**Contents**

**Copyrights and Trademarks**

Note for North American and Latin American Users. . . . . 2

**Notes on Manuals**

Meaning of Symbols. . . . . 5  
 Screenshots. . . . . 5  
 Illustrations. . . . . 5  
 Manual Organization. . . . . 5  
 Viewing Video Manuals. . . . . 6  
 Viewing PDF Manuals. . . . . 6

**Introduction**

Printer Parts. . . . . 8  
     Front Section. . . . . 8  
     Inside. . . . . 11  
     Back. . . . . 12  
     Ink Unit. . . . . 14  
 Control panel. . . . . 16  
 Understanding and Operating the Display. . . . . 17  
     Understanding the Display. . . . . 17  
     Operating procedure. . . . . 24  
 Understanding the Signal Lamps. . . . . 25  
 Notes on Usage and Storage. . . . . 26  
     Installation space. . . . . 26  
     Notes when using the printer. . . . . 26  
     Notes when not using the printer. . . . . 27  
     Notes on handling the ink supply units. . . . . 27  
     Notes on handling the ink unit. . . . . 28  
     Precautions When Handling and Storing Media. . . . . 28  
 Introducing the Supplied Software. . . . . 30  
     Supplied software. . . . . 30  
     Pre-installed software. . . . . 31  
 Using Epson Edge Dashboard. . . . . 32  
     Starting Procedure. . . . . 32  
     Registering the Printer. . . . . 32  
     Checking and Managing the Printer's Status. . . . . 33  
     Closing Procedure. . . . . 33  
 Using Epson Edge Print. . . . . 34  
     Configuration of main screen. . . . . 34  
     Printing with the appropriate settings for the media being used (printing using EMX). . . . . 37

Dividing a large image into parts to print it (tiling). . . . . 40  
 Using EPSON Software Updater. . . . . 44  
     Checking software update availability. . . . . 44  
     Receiving update notifications. . . . . 44  
 Using Web Config. . . . . 44  
     Starting Procedure. . . . . 44  
     Closing Procedure. . . . . 45  
 Uninstalling Software. . . . . 45

**Basic Operations**

Workflow for Correct Printing. . . . . 46  
 Notes on loading media. . . . . 47  
 Notes on Loading Media. . . . . 47  
 Loading media. . . . . 47  
 Settings for Loaded Media. . . . . 53  
 Using the Auto Take-up Reel Unit. . . . . 55  
     Attaching the Roll Core. . . . . 55  
     Take-up with the Printed Side Facing Out. . . . . 57  
     Take-up with the Printed Side Facing In. . . . . 59  
 Optimizing Media Settings (Automatic Adjustment). . . . . 61  
     Precautions when performing Print Adjustments. . . . . 61  
     Automatic Adjustment Procedure. . . . . 61  
     If you cannot perform Automatic Adjustment . . . . . 62  
 Replacing the Media. . . . . 64  
     Replacing Expended Media. . . . . 64  
     Replacing Media that is not Expended . . . . . 65  
 Removing the Take-up Roll. . . . . 66  
 Before Printing. . . . . 67  
 Changing settings during printing. . . . . 68  
     Changing the temperature for each heater. . . . . 68  
     Correcting Banding. . . . . 68  
 Printable area. . . . . 70

**Maintenance**

When to Perform Various Maintenance Operations. . . . . 73  
     Components Requiring Regular Cleaning and Cleaning Timing. . . . . 73  
     Locations of Consumables and Replacement Timing. . . . . 74  
     Other maintenance. . . . . 75

## Contents

What You'll Need. . . . .	76
Precautions regarding maintenance. . . . .	77
Performing Regular Cleaning. . . . .	77
Daily Cleaning. . . . .	77
Using Cleaning liquid. . . . .	78
Cleaning Around the Print Head. . . . .	79
Cleaning the anti-drying caps. . . . .	80
Cleaning the Suction Cap. . . . .	83
Cleaning Around the Flushing Pad. . . . .	84
Cleaning the Media Cleaner. . . . .	85
Shaking and Replacing Ink Supply Units. . . . .	87
Shaking. . . . .	87
Replacement procedure. . . . .	88
Disposing of Waste Ink. . . . .	89
Preparing and Replacement Timing. . . . .	89
Waste Ink Counter. . . . .	90
Replacing the Waste Ink Bottle. . . . .	90
Replacing the Wiper Unit. . . . .	91
Preparing and Replacement Timing. . . . .	91
Replacing the Wiper Unit. . . . .	92
Replacing the Media Edge Plates. . . . .	93
Disposal of used consumables. . . . .	94
Print Head Nozzle Check. . . . .	95
Types of Nozzle Checks. . . . .	95
How to Print a Nozzle Check Pattern. . . . .	95
Print Head Cleaning. . . . .	96
Types of Cleaning. . . . .	96
Performing Print Head Cleaning. . . . .	96
Long-term Storage (Pre-storage Maintenance). . . . .	97
Pre-storage Maintenance Timing. . . . .	97
Performing Pre-storage Maintenance. . . . .	97
Restarting use of the printer. . . . .	98
Cleaning the inside surface of the printer cover. . . . .	98
Cleaning pressure rollers. . . . .	99

### Control Panel Menu

Menu List. . . . .	100
Details of the Menu. . . . .	106
General Settings menu. . . . .	106
Media Settings menu. . . . .	112
Maintenance menu. . . . .	118
Supply Status menu. . . . .	119
Replacement Part Information menu. . . . .	119
Printer Status/Print menu. . . . .	120

### Problem Solver

When a Message is Displayed. . . . .	121
--------------------------------------	-----

When a Maintenance Call/Printer Error Occurs . . . . .	121
Troubleshooting. . . . .	122
You cannot print (because the printer does not work). . . . .	122
The printer sounds like it is printing, but nothing prints. . . . .	122
The prints are not what you expected. . . . .	123
Media. . . . .	124
Others. . . . .	127

### Appendix

Options and Consumable Products. . . . .	128
Ink Supply Unit. . . . .	128
Maintenance Items. . . . .	132
Supported Media. . . . .	134
Moving and Transporting the Printer. . . . .	134
Moving the Printer. . . . .	134
Transport. . . . .	138
Print Lengths by Pass Number and Creating a Job . . . . .	139
Table of Print Lengths by Pass Number. . . . .	139
Creating a job. . . . .	139
System Requirements. . . . .	140
Epson Edge Dashboard. . . . .	140
Epson Edge Print. . . . .	141
Web Config. . . . .	141
Specifications Table. . . . .	143

### Where To Get Help

Technical Support Web Site. . . . .	145
Contacting Epson Support. . . . .	145
Before Contacting Epson. . . . .	145
Help for Users in North America. . . . .	145
Help for Users in Latin America. . . . .	146
Help for Users in Europe. . . . .	147
Help for Users in Taiwan. . . . .	147
Help for Users in Australia/New Zealand. . . . .	148
Help for Users in Singapore. . . . .	148
Help for Users in Thailand. . . . .	148
Help for Users in Vietnam. . . . .	149
Help for Users in Indonesia. . . . .	149
Help for Users in Hong Kong. . . . .	149
Help for Users in Malaysia. . . . .	150
Help for Users in India. . . . .	150
Help for Users in the Philippines. . . . .	150

Notes on Manuals

# Notes on Manuals

## Meaning of Symbols

 <b>Warning:</b>	Warnings must be followed to avoid serious bodily injury.
---	---

 <b>Caution:</b>	Cautions must be followed to avoid bodily injury.
---	---

 <b>Important:</b>	Important must be followed to avoid damage to this product.
---	---

<b>Note:</b>	Notes contain useful or additional information on the operation of this product.
--------------	--

	Indicates related reference content.
---	--------------------------------------

## Screenshots

- Screenshots used in this manual may differ slightly from the actual screens.
- Unless otherwise stated, the Windows screenshots used in this manual are from Windows 10.

## Illustrations

Unless otherwise specified, the illustrations in this manual are for the SC-R5000 Series.

The illustrations may differ slightly from the model you are using. Please be aware of this when using the manual.

# Manual Organization

## Regions other than North America and Latin America

The manuals for the product are organized as shown below.

You can view the PDF manuals using Adobe Reader or Preview (Mac).

Setup Guide (booklet)	Provides information on how to setup the printer after unpacking it from the box. Make sure you read this manual to perform operations safely.
User's Guide (Excerpt) (PDF)	This manual explains the necessary basic operations and maintenance for daily use.
Online Manual	
User's Guide (this guide)	This manual explains basic operations, necessary items for daily use, maintenance operations, and troubleshooting.
Troubleshooting & Tips	This manual provides some frequently asked questions and tips to help you use the printer efficiently.
Epson Video Manuals	These videos show you how to load media and perform maintenance.
Network Guide (PDF)	This manual provides information on using the printer over a network.

## North America

To view user manuals, visit the support site for your region and search for your product.

- <https://www.epson.com/support> (U.S.)
- <http://www.epson.ca/support> (Canada)

## Latin America

To view user manuals, visit the support site for your region and search for your product.

- <http://www.latin.epson.com/support> (Caribbean)
- <http://www.epson.com.br/suporte> (Brazil)

Notes on Manuals

❑ <http://www.latin.epson.com/soporte> (other regions)

## Viewing Video Manuals

We have also posted video manuals on YouTube showing you how to load media and perform basic maintenance operations.

You can view the video manuals by clicking **Epson Video Manuals** from the top page of the *Online Manual*, or by clicking the following blue text.

[Epson Video Manuals](#)

You can also access the manuals from a smartphone or tablet by scanning the QR code attached to the printer.

If the subtitles are not displayed when you play the video, click the subtitles icon shown in the image below.

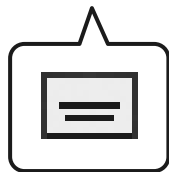

## Viewing PDF Manuals

This section uses the Adobe Acrobat Reader DC as an example to explain the basic operations for viewing the PDF in Adobe Reader.

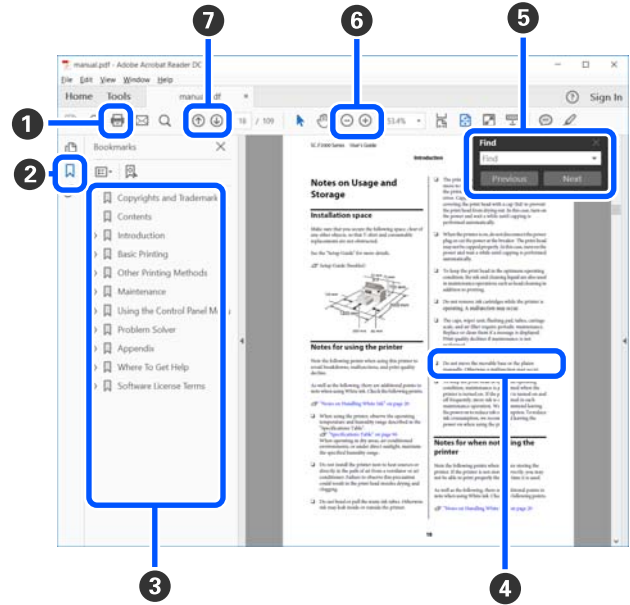

- ❶ Click to print the PDF manual.
- ❷ Each time it is clicked the bookmarks are hidden or shown.
- ❸ Click the title to open the relevant page.  
Click [+] to open the titles lower in the hierarchy.
- ❹ If the reference is in blue text, click the blue text to open the relevant page.

To return to the original page, do the following.

**For Windows**

While pressing the [Alt] key, press the [ ← ] key.

**For Mac**

While pressing the [command] key, press the [ ← ] key.

## Notes on Manuals

- 5 You can input and search for keywords, such as the names of items you want to confirm.

### For Windows

Right click on a page in the PDF manual and select **Find** in the menu that is displayed to open the search toolbar.

### For Mac

Select **Find** in the **Edit** menu to open the search toolbar.

- 6 To enlarge the text in the display that is too small to see well, click  $\oplus$ . Click  $\ominus$  to reduce the size. To specify a part of an illustration or screenshot to enlarge, do the following.

### For Windows

Right click on the page in the PDF manual and select **Marquee Zoom** in the menu that is displayed. The pointer changes to a magnifying glass, and you can use it to specify the range of the place you want to enlarge.

### For Mac

Click **View** menu - **Zoom** - **Marquee Zoom** in this order to change the pointer to a magnifying glass. Use the pointer as a magnifying glass to specify the range of the place you want to enlarge.

- 7 Opens the previous page or next page.

# Introduction

## Printer Parts

### Front Section

The illustration shows the SC-R5000 Series.

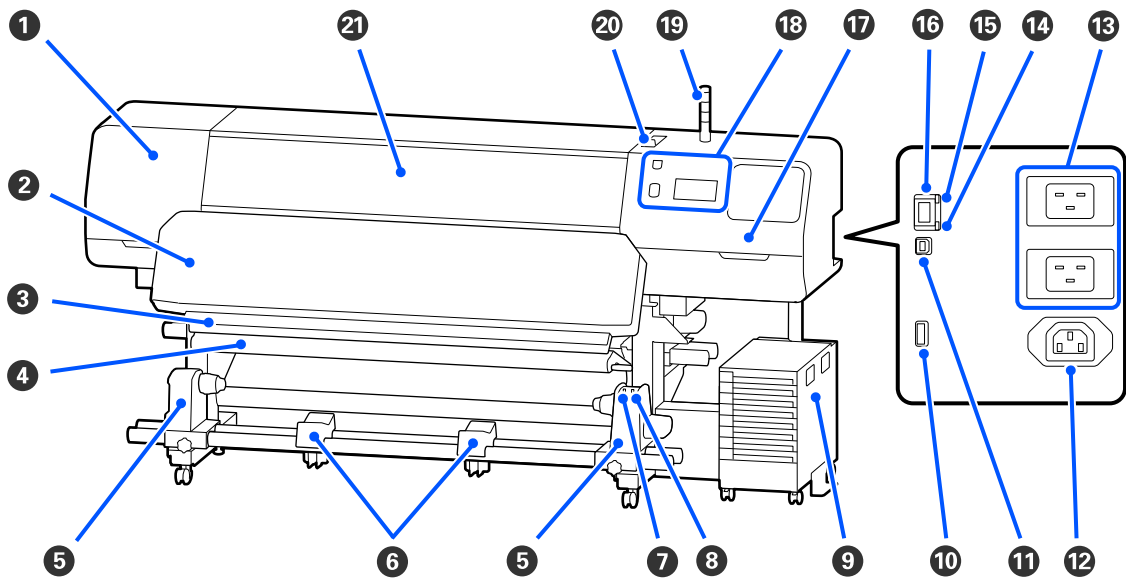

#### 1 Maintenance cover (left)

Open this cover to clean the area around the print head. Normally closed when using the printer.

 [“Cleaning Around the Print Head” on page 79](#)

#### 2 Curing heater

Cures and fixes the ink in the printouts. If you touch print outs containing ink that has not been cured, your hands will be soiled with ink.

#### 3 Cutter groove

Pass the blade of a cutter (available in the market) down this groove to cut media.

 [“Replacing Media that is not Expended ” on page 65](#)

#### 4 Tension bar

The tensioner maintains tension to prevent the media sagging as it is taken up.

 [“Using the Auto Take-up Reel Unit” on page 55](#)



## Introduction

### 5 Media holder

Place the roll core for media take-up on these holders. There are same parts on both the left and the right.

 [“Using the Auto Take-up Reel Unit” on page 55](#)

### 6 Media support

Rest media temporarily on these supports when removing the take-up roll. There are same parts on both the left and the right.

### 7 Auto switch

Use this switch to select the auto take-up direction. If Off is selected, the paper is not taken up.

### 8 Manual switch

Use this switch to take-up manually. You can use this when the Auto switch is in the Off position.

### 9 Ink unit

 [“Ink Unit” on page 14](#)

### 10 Optional port

Connect the connection cable supplied with the ink unit.

Regions other than North America and Latin America:  [Setup Guide](#) (booklet)

North American and Latin American users: Contact your dealer for product installation. The product must be installed by an authorized dealer. Damage to the product from unauthorized installation will not be covered by your Epson warranty.

### 11 USB port

Connect to your computer with a USB cable.

### 12 AC outlet #3

Connect the power cable supplied with the ink unit.

Regions other than North America and Latin America:  [Setup Guide](#) (booklet)

North American and Latin American users: Contact your dealer for product installation. The product must be installed by an authorized dealer. Damage to the product from unauthorized installation will not be covered by your Epson warranty.

### 13 AC inlet #1/AC inlet #2

Connect the power cable supplied with the printer. Be sure to connect both cables.

### 14 Data lamp

The data lamp lights or flashes to indicate the network connection status and whether the printer is receiving data.

On : Connected.

Flashing : Connected and receiving data.

## Introduction

### 15 Status lamp

The color indicates the network's communication speed.

Red : 100Base-TX

Green : 1000Base-T

### 16 LAN port

Connects the LAN cable. Use a shielded twisted pair cable (category 5 or higher).

### 17 Maintenance cover (right)

Open this when replacing the wiper unit or when cleaning around the caps. Normally closed when using the printer.

 [“Cleaning the anti-drying caps” on page 80](#)

 [“Cleaning the Suction Cap” on page 83](#)

### 18 Control panel

 [“Control panel” on page 16](#)

### 19 Signal lamp

The status of the printer is indicated by whether or not the three color lamps are lit or flashing. When all of the lamps are off, the printer is off.

The following explains the basic meanings for the color of the lamps.



Red : Cannot print as an error has occurred.

Yellow : The printer is being operated while a warning message is displayed, maintenance is being performed, or the printer is paused.

Green : Ready to print or currently printing.

The combination of lamp colors and whether they are lit or flashing provides detailed information about the status of the printer.

See the following for more details on understanding the signal lamp.

 [“Understanding the Signal Lamps” on page 25](#)

### 20 Media loading lever

Once media has been loaded, move the media loading lever to the front to press down on the media. Move the media loading lever to the back to release the media prior to removal.

### 21 Printer cover

Open when loading media, cleaning the inside of the printer, or removing jammed media. Normally closed when using the printer.

## Introduction

### Inside

Dirt on any of the following parts may reduce print quality. Regularly clean or exchange these parts as described in the chapters listed in the reference sections below.

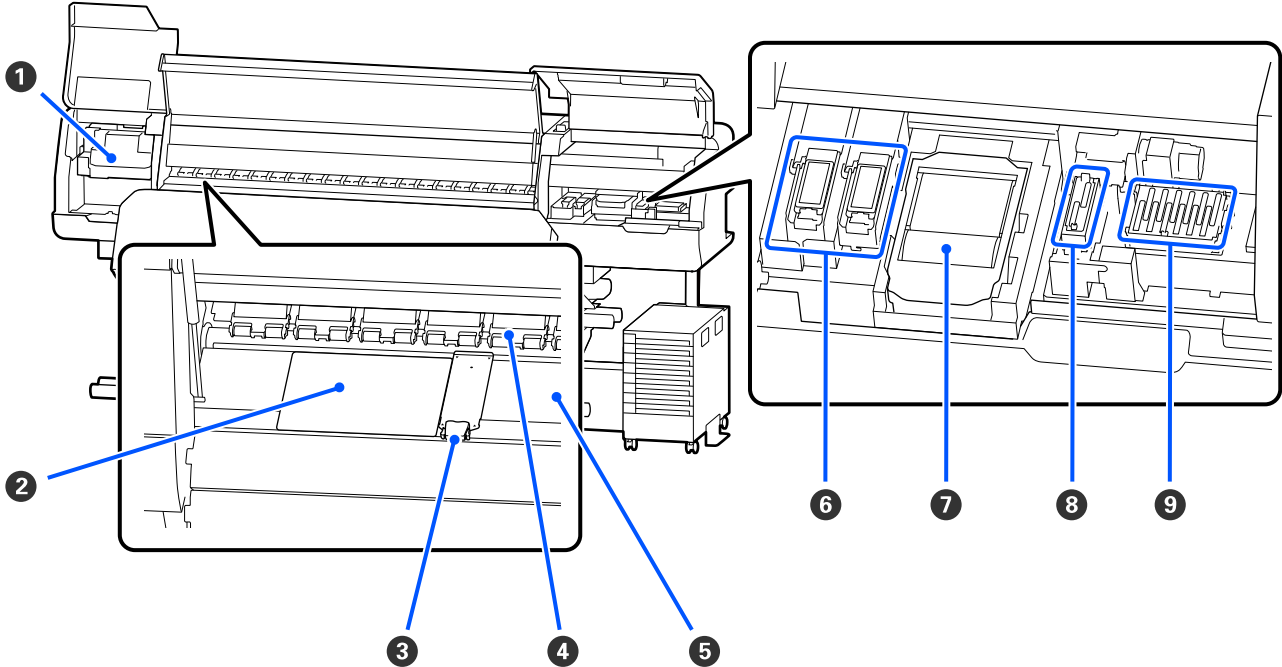

#### 1 Print head

The print head prints by moving left and right while emitting ink. Follow the messages on the control panel to perform cleaning.

 [“Cleaning Around the Print Head” on page 79](#)

#### 2 Thermal sheet

Prevents uneven heat distribution in the platen heater thereby preventing poor quality prints. Make sure you use a thermal sheet if the width of the loaded media is 54 inches or less.

#### 3 Media edge plates

The media edge plates prevent the media riding up and keeps fibers on the cut edge of the media from touching the print head. Position the plates at either side of the media before printing.

 [“Loading media” on page 47](#)

#### 4 Pressure rollers

These rollers press down on the media during printing. These moves up and down in conjunction with the media loading lever.

## Introduction

### 5 Platen heater

The platen heater ensures that the ink adheres evenly. If lint, dust, or ink adheres to this, it could cause clogged nozzles or ink drops to occur, so be sure to clean it daily.

☞ [“Daily Cleaning” on page 77](#)

### 6 Flushing pad

Color ink and Optimizer (OP) are discharged onto this pad during flushing. The right side is for OP, and the left side is for ink. Check this during regular cleaning and clean it if it is dirty.

☞ [“Cleaning Around the Flushing Pad” on page 84](#)

### 7 Wiper Unit

Used to wipe off ink that is stuck to the surface of the print head nozzles. The wiper unit is a consumable item. Replace when a message is displayed on the control panel prompting you to do so.

☞ [“Replacing the Wiper Unit” on page 91](#)

### 8 Suction Cap

Use this cap to suck the ink out of the print head. Follow the messages on the control panel to perform cleaning.

☞ [“Cleaning the Suction Cap” on page 83](#)

### 9 Anti-drying caps

Except during printing, these caps cover the print head nozzles to prevent them drying out. Clean when a message is displayed on the control panel prompting you to do so.

☞ [“Cleaning the anti-drying caps” on page 80](#)

---

## Back

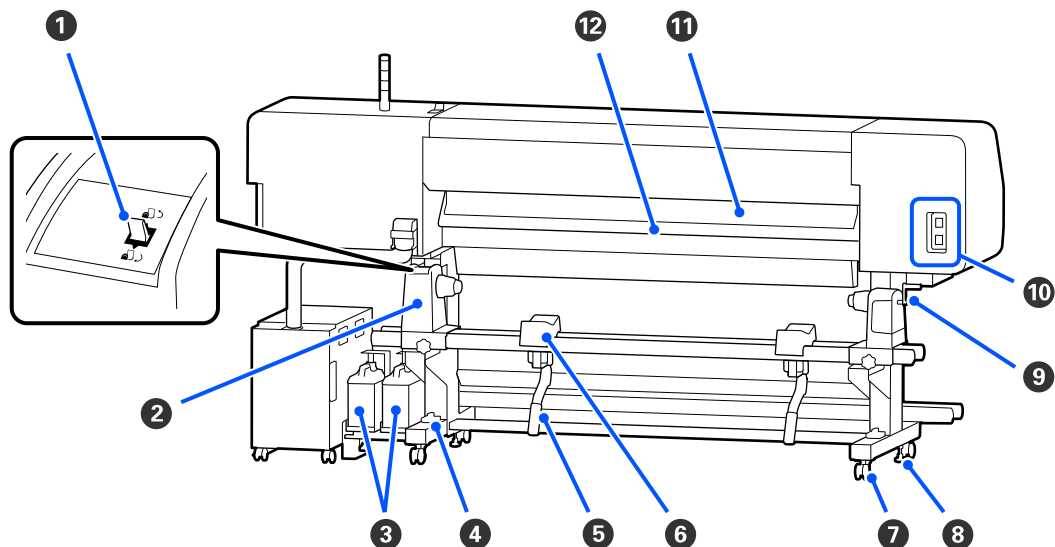

## Introduction

### 1 Drive switch

Rewinds media during media replacement.

### 2 Media holder

Place media on these holders. There are same parts on both the left and the right.

### 3 Waste Ink Bottle

Waste ink collects in this bottle. There are two waste ink bottles; for color ink on the left and Optimizer (OP) on the right.

Replace it with a new waste ink bottle when a message is displayed on the control panel prompting you to do so.

 [“Disposing of Waste Ink” on page 89](#)

### 4 Level gauge

When installing on a carpeted floor or a sloping floor, check the horizontal level of the printer. There are same parts on both the left and the right.

Regions other than North America and Latin America:  [Setup Guide](#) (booklet)

North American and Latin American users: Contact your dealer for product installation. The product must be installed by an authorized dealer. Damage to the product from unauthorized installation will not be covered by your Epson warranty.

### 5 Lift lever

If the media to be mounted on the media holder seems heavy, use these levers to raise the media to the level of the media holder. There are same parts on both the left and the right.

### 6 Media support

Rest media on these supports before placing it on the media holder. There are same parts on both the left and the right.

### 7 Casters

There are two casters on each leg. Once installation is complete, the casters should be kept locked while the printer is in use.

### 8 Adjusters

There are two adjusters on each leg. When installing on a carpeted floor or a sloping floor, check level gauge of the printer and adjust these to keep the printer stable. If you perform horizontal adjustment during installation, make sure you raise the levelers above the casters before moving the printer.

 [“Moving the Printer” on page 134](#)

### 9 Handle

After placing media on the right media holder, rotate the handle to press the media holder and apply pressure to the roll core.

## Introduction

### 10 AC outlet #4/AC outlet #5

Connect the power cable supplied with the curing heater. Be sure to connect both cables.

### 11 Media cleaner

Removes lint and dust from the surface of the media.

 [“Cleaning the Media Cleaner” on page 85](#)

### 12 Pre-heater

Heats the media before printing so that the print area is not subject to sudden changes in temperature.

## Ink Unit

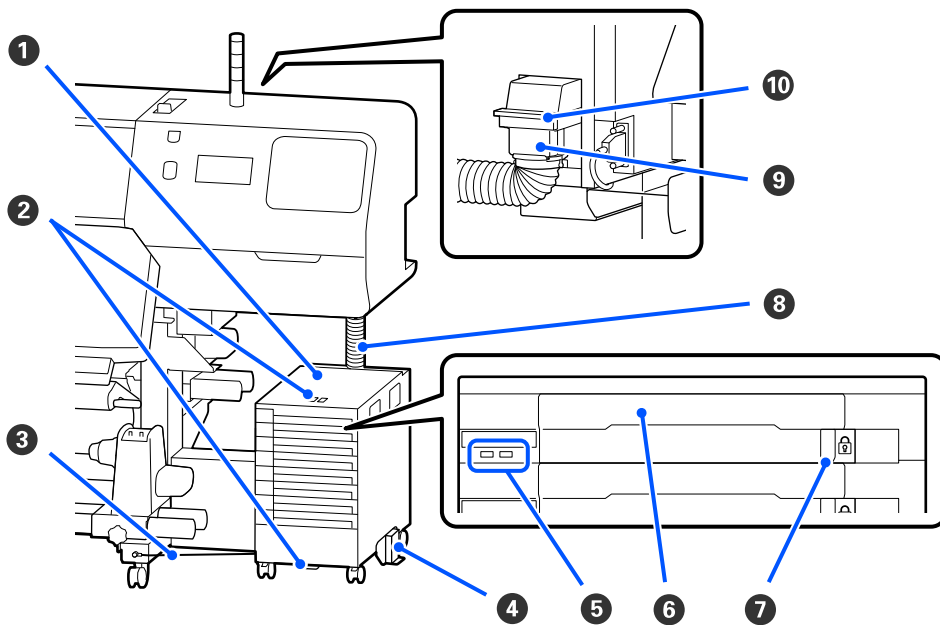

### 1 Ink unit

The ink unit supplies ink to the printer. Insert ink supply units into all the ink supply unit trays.

### 2 Security cable bracket

Pass a commercially available security cable through the upper and lower mounting parts to prevent the ink supply unit from being stolen.

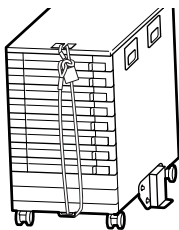

## Introduction

### 3 Ink unit wire

When in use, be sure to use screws to fasten the ink unit wire to the front and back of the printer's legs. The ink tube may break if you move the ink unit while it is connected to the printer without being fastened with the ink unit wire.

### 4 Overturn-prevention plate

Make sure the ink unit is used with an overturn-prevention plate attached to both sides to prevent the ink unit from overturning.

### 5 LED light

The LED lamp indicates, by lighting or flashing, the ink supply units inserted into their ink supply unit trays and the ink unit, as shown below.

Lit blue : Ink is being supplied to the printer. Do not pull out the ink supply unit tray.

Flashing blue : It is time to shake the ink supply unit. Pull out the ink supply unit tray and shake it.

 [“Shaking” on page 87](#)

Lit or flashing orange: An error or warning has occurred. The type of error or warning is indicated by how the lamp lights or flashes. You can check the details of the error or warning on the control panel's screen.

Off : No error. You can pull out the ink supply unit tray if necessary.

### 6 Ink supply unit tray

Insert the ink supply unit for the color indicated on the label. Place all of the ink supply unit trays in the ink unit.

### 7 Lock switch

To pull out an ink supply unit tray, unlock it by moving the lock switch to the right. After placing the ink supply unit tray in the ink unit, lock it by moving the lock switch to the left.

### 8 Ink tube

This tube supplies ink from the ink supply unit to the printer.

### 9 Ink tube connector

This connector connects the ink tube and the printer. This is used with the ink tube and printer connected normally, except for when transporting the printer.

### 10 Connector lock levers

Locks the ink tube connector. Do not use this after it is locked during setup.

**Introduction**

# Control panel

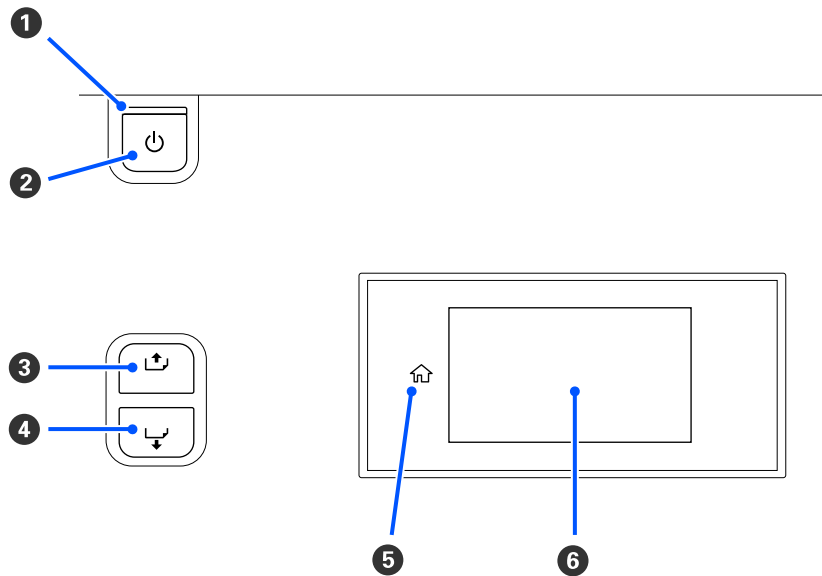

**1  light (power light)**

The printer's operational status is indicated by a lit or flashing light.

On  : The power is on.

Flashing : The printer is operating such as receiving data, shutting down, or performing Print Head Cleaning.

Off  : The power is off.

**2  button (power button)**

Turns the power on and off.

**3 [  ] button (rewind button)**

Depending on the status of the media loading lever, operations differ as shown below.

- When the media loading lever is moved to the front  
You can rewind the media by holding down the button. Rewinding stops when the leading edge of the media reaches the print start position. Rewind can be resumed by releasing the button and then pressing it again. Press and hold the button to speed up the rewinding. This is useful when fine-tuning media alignment as you can rewind the media in increments of 0.4 mm by pressing the button briefly.
- When the media loading lever is moved to the back  
You can rewind media that has been loaded with the printable side out by holding down the button.

**4 [  ] button (feed button)**





## Introduction

Depending on the status of the media loading lever, operations differ as shown below.

- ❑ When the media loading lever is moved to the front  
You can feed the media by holding down the button. Press and hold the button to speed up the feeding. This is useful when fine-tuning media alignment as you can feed the media in increments of 0.4 mm by pressing the button briefly.
- ❑ When the media loading lever is moved to the back  
You can rewind media that has been loaded with the printable side in by holding down the button.

### 5 (Home)

Press to return to the home screen during menu operations and so on (when  is lit).

 (Home) is not lit when it cannot be used

### 6 **Screen**

Displays the printer's status, menus, error messages, and so on.  [“Understanding and Operating the Display” on page 17](#)

# Understanding and Operating the Display

---

## Understanding the Display

This section explains how to view the following two screens.

### Home screen

You can check the current status of the printer.

### Startup adjustment screen

You can quickly change the major adjustment values. This is useful when you need to make frequent adjustments to stabilize the print quality, such as when you start using new media.

You can switch between the home screen and the startup adjustment screen each time you press .

## Introduction

### Home screen

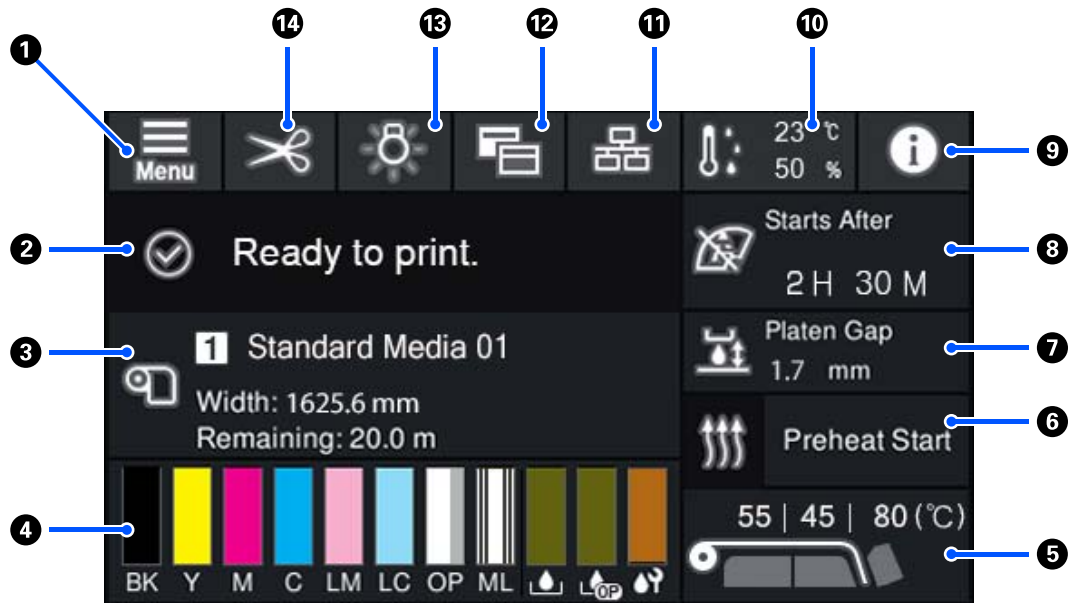

#### 1 (Menu)

The settings menu will be displayed.

[“Control Panel Menu” on page 100](#)

#### 2 **Status display area**

Displays the printer's status and warning messages. Only the most recent notifications are shown in this area. You can check all warning notifications by pressing .

When a print job is received, the displayed content changes as shown below. The following provides an explanation of each display.

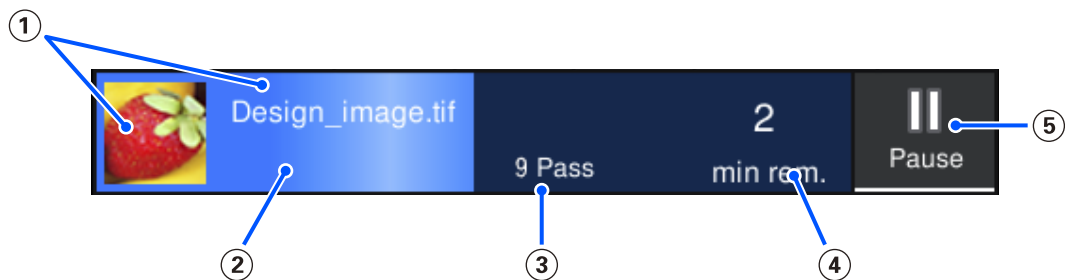

① Displays a preview of the image being printed and the file name.

② Displays a progress bar showing the printing progress.

③ Displays the number of print passes.

④ Displays the estimated time until printing is complete. This includes the heating time necessary for the heater to reach the set temperature, the curing time after printing, and, depending on the settings, the warm-up time for the print head.

## Introduction

- ⑤ This is the Pause (Suspend) button.

Press this button and select whether to stop printing immediately (**Immediate pause**) or stop after printing the current page (or job if it is a single page) (**Pause between pages**). Pressing **Resume** on the screen during a pause resumes printing. However, if you select **Immediate pause**, printing may become disrupted when printing restarts.

Appears as the **Cancel** button while warming up, until the heater reaches the set temperature. Press this button to cancel the job. This button appears as **Start** while warming up when printing an adjustment pattern, and you can press this to start printing even if the temperature of the heater is low.

### ③ Media info

Displays the name and number of the currently selected registered media, as well as the width of the currently loaded media. When **Remaining Amount Management** is set to **On**, the remaining amount of the loaded media is also displayed. Pressing this area displays the **Media Settings** from the settings menu where you can change to a different registered media number or change the settings for the media number that is currently selected.

### ④ Status of consumables

Displays the approximate amount remaining and the status of consumables such as the ink supply unit. Pressing this area allows you to check details for the amount remaining and the part number of each consumable.

If you are using the SC-R5000L Series, pressing this area allows you to perform the following checks and settings.

- Check which ink supply unit is currently operating or supplying ink
- Check the status of non-operational ink supply units
- Manually switch the operational ink supply unit

The following provides an explanation of each display.



#### Ink supply unit status

Indicates the approximate amount of ink remaining. The bar goes lower as the remaining ink runs low. The letters under the bar are abbreviations of the colors. The relation of the abbreviations and the ink colors is shown below.

BK : Black

Y : Yellow

M : Magenta

C : Cyan

LM : Light Magenta

LC : Light Cyan

OP : Optimizer

ML : Maintenance Liquid

Depending on the status of the ink supply unit, the display of the bar changes as shown below.

## Introduction



: Ink is low. You need to prepare a new ink supply unit.

If you are using the SC-R5000L Series, the ink supply automatically switches to another ink supply unit of the same color, so make sure that the ink supply unit that is being switched to has enough ink.



: Ink is expended. Replace the old ink supply unit with a new one.

If you are using the SC-R5000L Series, when ink is expended, the ink supply automatically switches to another ink supply unit of the same color.



: It is time to shake the ink supply unit. Remove the ink supply unit tray for any ink unit whose LED light is flashing blue, and then shake the tray. Do not pull out the ink supply unit tray if the light is lit blue.



: Only displayed when using the SC-R5000L Series.

An ink supply unit tray without an ink supply unit attached has been installed in the ink unit. Attach the ink supply unit as soon as possible, otherwise the ink unit could malfunction.



: Only displayed when using the SC-R5000L Series.

Make sure all of the ink unit lock switches are locked, and then follow the instructions displayed on the screen.



: The cleaning ink supply unit is installed.



### Waste Ink Bottle status

Indicates the approximate amount of space available in the waste ink bottle. The bar goes lower as the amount of remaining space decreases. The letters under the bar are identification abbreviations of the waste ink bottles. The meanings of the abbreviations are shown below.



: Waste ink bottle for color ink



: Waste ink bottle for Optimizer (OP)

Depending on the status of the waste ink bottle, the display of the bar changes as shown below.



: The waste ink bottle is almost full. Ready a new Waste Ink Bottle.



### Wiper unit status

Indicates the approximate amount of wiper unit remaining. The bar goes lower as the remaining ink runs low.





: The wiper unit is running low, so you need to prepare a new wiper unit.

## Introduction

### 5 Heater temperature

Displays the temperature set for each heater. The temperatures are displayed in the following order from the left: pre-heater, platen heater, curing heater. The icon under the number changes as shown below depending on the temperature of each heater.

 : Heating.

 : Cooling.

### 6 Preheat Start/Stop

Each heater starts heating when a job is sent, and printing starts when all heaters reach a set temperature.

Press **Preheat Start** to start pre-heating each heater, and then the pre-heater and platen heater maintain a constant set temperature. The curing heater maintains a standby temperature.

Pre-heating allows you to start printing quickly once a job has been sent.

You can start/stop pre-heating for all heaters each time you press this area. Additionally, all heaters turn off after the time set in **Heater Off Timer** in the settings menu has elapsed. Heating starts when a print job is sent, but you can still press **Preheat Start** if necessary.

Also, if **Heater** from **Temperature** is set to **Off** in the settings menu, pressing **Preheat Start** does nothing and pre-heating does not start. Heaters that are set to **Off** do not heat up even if a job is sent. You can make **Heater** settings for each heater.

### 7 Platen Gap

Displays the Platen Gap settings for the current media information (3). Press this area to display the settings screen where you can change the values.

### 8 Notice on when to perform maintenance or Periodic Cleaning

Displays the remaining print time until maintenance or Periodic Cleaning is performed.



The printer estimates how long it will take to print the job, and if the print time is longer than the displayed time, Print Head Cleaning is automatically performed before printing starts.

You can press this area to perform Print Head Cleaning if necessary.

Depending on the temperature around the print head and the status of ink ejection during printing, this may be performed sooner to protect the print head.

Also, maintenance cleaning may be performed regardless of the notification when the printer is turned back on.

### 9 (Printer Status)

If a warning notification has been generated,  is displayed on the right just like . Press **Message List** on the screen displayed when you press this area to display a list of warning notifications. You can check detailed information and the handling procedure for each item by pressing it in the list. Items are removed from the list as those actions are taken.

## Introduction

### 10 (environmental temperature and humidity)

Displays the current temperature and humidity. Press this area to view a range of the printer's operating temperature and humidity. You may not be able to print correctly unless you use the printer under the appropriate environmental conditions.

### 11 (Switch connection status)

The following icons indicate the connection status between the computer and the printer.

Connection :   
on

Connection :   
off

The connection turns on or off every time this area is pressed.

For example, you can finish work more efficiently by turning the connection off to prevent jobs from being received before performing maintenance such as printing a nozzle check pattern or executing Print Head Cleaning after cleaning around the print head.

Note that you may not be able to switch depending on the operating status of the printer. In this situation, the icon is grayed out indicating that the function is disabled.

### 12 (Switch screens)

Switch between the home screen and the startup adjustment screen every time this area is pressed.

### 13 (Inside light)

Switches the internal lamp on or off. Press this area to turn off the inside light, when it is on. Pressing it while the inside light is off, turns it on.

You may not be able to turn this on/off depending on the operating status of the printer. In this situation, the icon is grayed out indicating that the function is disabled.

### 14 (feed media to cutting position)

Depending on the settings for the currently selected registered media, the end of the print may be on the platen after printing is complete.

If you want to send the end of the print to the cutting position, you can press this area to feed the media to the cutting position. Furthermore, if you perform an operation to feed the end of the print to the cutting position while it is in the cutting position, the print start position on the platen is fed to the cutting position.

## Introduction

### Startup adjustment screen

The following section only describes parts that differ from the home screen. You can change the value for each adjustment item even while printing. Results of the adjustments are registered to the currently selected media settings.

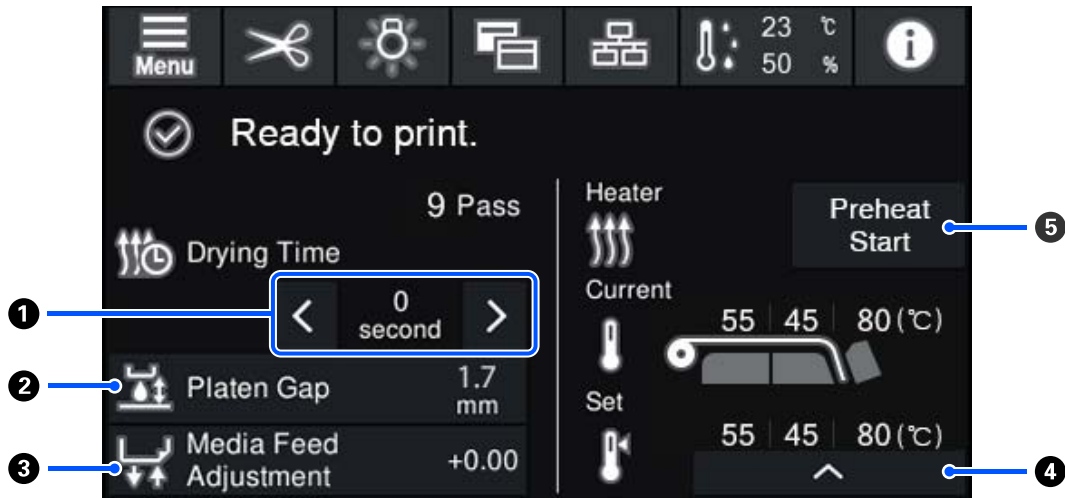

#### 1 Adjusting the Drying Time

When **Drying Action** is set to **Follow Drying Time Setting**, the **Drying Time** setting for the selected Pass Mode for the currently selected registered media number is displayed. Press the following to change the value.

◀ : To reduce the display time

▶ : To increase the display time

#### 2 Adjusting the Platen Gap

Displays the Platen Gap setting for the current media settings. Press this area to change the setting.

#### 3 Correcting the media feed

To correct banding that occurs during printing, press this area to perform media feed corrections.

If the feed amount is too small, black bands (dark stripes) appear; correct the feed amount upwards (+).

In contrast, if the feed amount is too large, white bands (pale stripes) appear; correct the feed amount downwards (-). The value indicates the amount of feed that has been corrected as a percentage or as a positive (+) or negative (-) value.

#### 4 Adjusting the heater temperature

Press ▲ to change the set temperature for the pre-heater, platen heater, or curing heater. Depending on the media loaded and the current number of print passes, if the temperature for curing heater is too low, the ink will not be cured correctly and the back of the media will be stained with ink when winding. On the other hand, if the temperature is too high, it will cause the media to shrink and warp. If the temperature of the platen heater is raised too high, the nozzles may become clogged. When changing the temperature, make sure you adjust to an appropriate temperature.

## Introduction

### 5 Preheat Start/Stop

Each heater starts heating when a job is sent, and printing starts when all heaters reach a set temperature.

Press **Preheat Start** to start pre-heating each heater, and then the pre-heater and platen heater maintain a constant set temperature. The curing heater maintains a standby temperature.

Pre-heating allows you to start printing quickly once a job has been sent.

You can start/stop pre-heating for all heaters each time you press this area. Additionally, all heaters turn off after the time set in **Heater Off Timer** in the settings menu has elapsed. Heating starts when a print job is sent, but you can still press **Preheat Start** if necessary.

Also, if **Heater** from **Temperature** is set to **Off** in the settings menu, pressing **Preheat Start** does nothing and pre-heating does not start. Heaters that are set to **Off** do not heat up even if a job is sent. You can make **Heater** settings for each heater.

---

## Operating procedure

The black background area on the home screen and the startup adjustment screen does not respond even if you press it. When you press the gray tiled area in the operation area, the screen or the value changes.

Depending on the printer's operating status, you may not be able to perform the function for every button displayed at the top of the screen. If the function is unavailable, the icon is grayed out and the button does not respond.

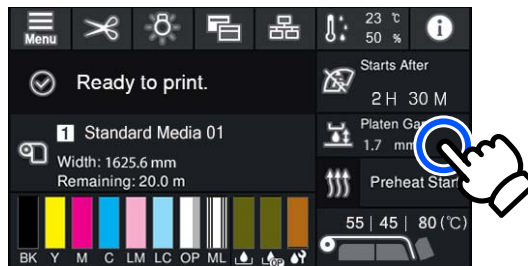

Operation areas do operations when pressed. However, when a scroll bar is displayed as shown below, you can scroll the screen by moving (sliding) your finger up and down on the screen. You can also scroll by pressing on the up and down icons on the scroll bar.

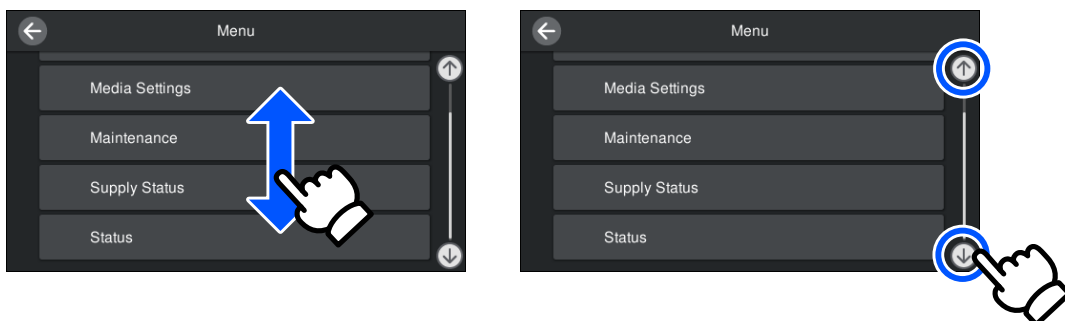



## Introduction

If the following **How To...** button is displayed on a message screen and so on, you can press this button to view a guide for the operating procedure.

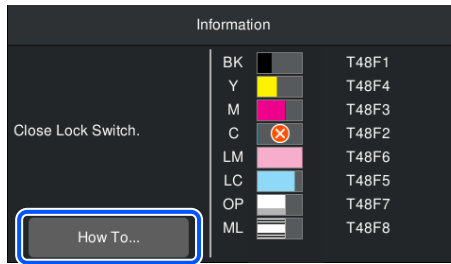

## Understanding the Signal Lamps

The status of the printer is indicated by whether or not the three color lamps are lit or flashing. The lamp colors are red, yellow, and green from top to bottom. When red or yellow is lit or flashing, an error or warning has occurred on the printer. You can check the details of the error or warning on the control panel's screen.

Lamp Status			Printer Status
Red	Yellow	Green	
Off	Flashing	Off	Performing startup/shutdown operations
Off	Off	On	Standing by (printer is ready)
Off	Off	Flashing	Middle Of Page
Off	On	Light/Flash	Consumables need to be replaced soon
Off	On	Off	Cannot start printing
On	Off	Off	Error occurred Check the content of the error on the screen.
Flashing	Off	Off	Errors that cannot be cleared After confirming the message displayed on the screen, contact your dealer or Epson Support for assistance.
Off	Flashing	Off	Performing maintenance
Off	On	On	Paused (printing stopped)
Off	On	Flashing	Paused (printing)
Off	On	Off	Connection off (cannot accept jobs)

## Introduction

## Notes on Usage and Storage

### Installation space

Make sure that you secure the following space, clear of any other objects, so that paper ejection and consumable replacement are not obstructed.

See the "Specifications Table" for the external dimensions of the printer.

 ["Specifications Table" on page 143](#)

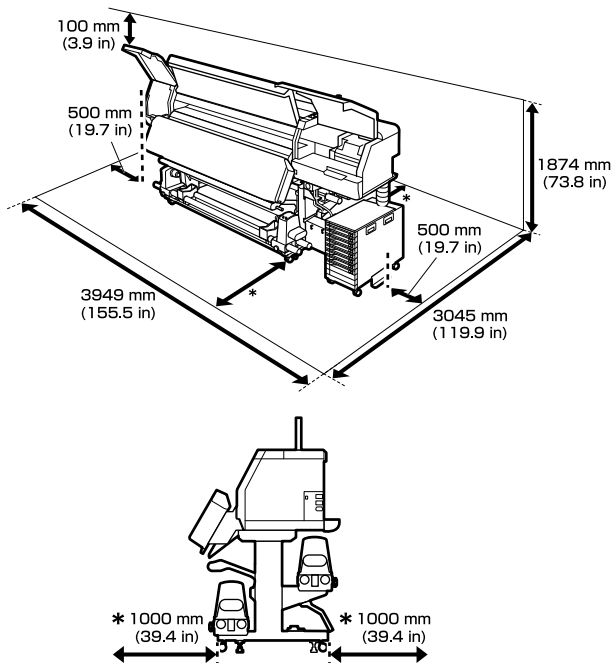

### Notes when using the printer

Note the following points when using this printer to avoid breakdowns, malfunctions, and print quality decline.

- ❑ We recommend keeping the printer turned on at all times to prevent the print head from clogging. If the printer is turned off, make sure you turn it on once a week.

- ❑ When using the printer, observe the operating temperature and humidity range described in the "Specifications Table".  ["Specifications Table" on page 143](#)

Note, however, that the desired results may not be achieved if the temperature and humidity are within the limits for the printer but not within those for the media. Be sure the operating conditions suit the media. For more information, see the documentation supplied with the media.

Also, when operating in dry areas, air conditioned environment, or under direct sunlight, maintain the appropriate humidity.

- ❑ Avoid using the printer in locations with heat sources or that are exposed to direct draughts from ventilators or air conditioners. The print head nozzles could dry out and clog.

- ❑ Do not bend or tug the waste ink tube. Ink could spill inside or around the printer.

- ❑ Maintenance such as cleaning and replacement must be performed according to usage frequency or at recommended intervals. Failure to perform regular maintenance could result in loss of print quality. In the absence of the appropriate maintenance, continued use could damage the print head.

 ["Components Requiring Regular Cleaning and Cleaning Timing" on page 73](#)

- ❑ The print head may not be capped (the print head may not return to the right side) if the printer is turned off when media is jammed or an error has occurred. Capping is a function that automatically covers the print head with a cap (lid) to prevent the print head from drying out. In this case, turn on the power and wait a while until capping is performed automatically.

- ❑ When the power is on, do not remove the power plug or cut the power at the breaker. Otherwise, the print head may not be capped properly. In this case, turn on the power and wait a while until capping is performed automatically.

- ❑ Print Head Cleaning is performed automatically for the print head at a fixed interval after printing to keep the nozzles from clogging. Be sure that the Waste Ink Bottle is placed whenever the printer is on.

## Introduction

- ❑ As well as being expended during printing, ink is used during Print Head Cleaning and other maintenance operations required to keep the print head in working order.

---

### Notes when not using the printer

If you are not using it, note the following points when storing the printer. If it is not stored correctly, you may not be able to print properly the next time it is used.

- ❑ If the printer will not be used for more than two weeks (and will be turned off at this time), use the cleaning ink supply unit (sold separately) and perform pre-storage maintenance. Leaving the heads unwashed causes permanent clogs. See the following for more information.
  - 🔗 [“Long-term Storage \(Pre-storage Maintenance\)” on page 97](#)
- ❑ If you do not print for a long time and do not perform pre-storage maintenance, turn the printer on at least once a week.
 

If you do not print for a long time, the print head nozzles may become clogged. Print Head Cleaning will be performed automatically after the printer is turned on and started. Print Head Cleaning prevents clogged print heads and maintains print quality. Do not turn the printer off until Print Head Cleaning is complete.
- ❑ If you have not used the printer for a long time, check the print head for clogging before you start printing. Perform Print Head Cleaning if the print head is clogged.
  - 🔗 [“How to Print a Nozzle Check Pattern” on page 95](#)
- ❑ When storing the printer in an environment below -15°C (5°F), make sure you execute **Keeping Preparation** in the settings menu. If the printer is stored without executing this procedure, the print head could be damaged.
  - 🔗 [“Long-term Storage \(Pre-storage Maintenance\)” on page 97](#)
- ❑ The pressure rollers may crease media left in the printer. The media may also become wavy or curled, causing jams or resulting in the media coming into contact with the print head. Remove the media before putting the printer in storage. After removing the media, move the media loading lever to the front.

- ❑ Store the printer after confirming that the print head has been capped (the print head is positioned at the far right). If the print head is left uncapped for a long time, the print quality may decline.

**Note:**

*If the print head is not capped, turn the printer on, and then turn it off.*

- ❑ Close all covers before placing the printer in storage. If you are not using the printer for a long time, put an anti-static cloth or cover on the printer to prevent dust. The print head nozzles are very small, and they can become clogged easily if fine dust gets on the print head, and you may not be able to print properly.
- ❑ When storing the printer, be sure that it is level: do not store it on an angle, on end, or upside down.



---

### Notes on handling the ink supply units

Note the following points when handling ink supply units to maintain good print quality.

- ❑ Extra ink is required to fully charge the print head nozzles the first time the printer is used; therefore, replacement ink supply units will be needed earlier than usual.
- ❑ Store ink supply units at room temperature out of direct sunlight.
- ❑ To ensure print quality, we recommend using all of the ink before whichever of the following dates is earlier:
  - ❑ The expiry date shown on the ink supply unit packaging
  - ❑ One year from the date the ink supply unit was installed in the ink unit
- ❑ If you move the ink supply units from a cold place to a warm place, leave them at room temperature for more than four hours before using them.
- ❑ Do not touch the ink supply unit IC chip. You may not be able to print properly.

## Introduction

- ❑ Do not leave the ink unit without any ink supply units installed. The ink in the printer will dry out and the printer will not function as expected. Leave ink supply units installed even when the printer is not in use.
- ❑ Because the IC chip manages the ink supply unit's own information, such as the remaining ink level, you can still re-insert and use them if you removed them before the replacement message appears.
- ❑ Before you store ink supply units that you remove during use, use a cleaning stick from the supplied Cleaning Kit to absorb any ink stuck to their ink supply ports. Dried ink on the supply port may cause ink leaks when the ink cartridge/ink supply unit is reinserted and used. See the following for more information on cleaning methods.  
 [“Long-term Storage \(Pre-storage Maintenance\)” on page 97](#)  
 While ink cartridges/ink supply units are in storage, keep the ink supply ports free of dust. The ink supply port has a valve in it so it does not need to be capped.
- ❑ Removed ink supply units may have ink around the ink supply port, so be careful not to get any ink on the surrounding area when removing the ink supply units.
- ❑ To maintain the quality of the print head, this printer stops printing before ink supply units are completely expended.
- ❑ Although the ink supply units may contain recycled materials, this does not affect printer function or performance.
- ❑ Do not dismantle or remodel ink supply units. You may not be able to print properly.
- ❑ Do not drop or knock an ink supply unit against hard objects; otherwise, the ink may leak from the ink supply unit.
- ❑ Remove the ink supply units installed in the ink unit once a week and shake them thoroughly. You do not need to shake the ink supply units for OP or ML.  
 [“Shaking” on page 87](#)

---

## Notes on handling the ink unit

- ❑ Use the ink unit wire to fasten the ink unit to the front and back of the printer's legs. The ink tube may break if you move the ink unit while it is connected to the printer without being fastened with the ink unit wire.
- ❑ Do not remove the ink tube connector once it has been connected during setup. Ink may leak if you remove this without paying close attention.

---

## Precautions When Handling and Storing Media

Note the following when handling or storing media. Media that are in poor condition will not produce good quality prints.

Be sure to read the documentation provided with each type of media.

## Precautions when handling and storing

- ❑ Do not fold the media or damage the printable surface.
- ❑ Do not touch the printable surface. Moisture and oils from your hands can affect print quality.
- ❑ When handling media, hold it by both edges. We recommend wearing cotton gloves.
- ❑ Keep the media dry.
- ❑ Packaging materials can be used to store media and should not be thrown away.
- ❑ Avoid locations that are subject to direct sunlight, excessive heat, or humidity.
- ❑ When not in use, media should be removed from the printer, rewound, and inserted in its original packaging for storage.

## Introduction

- ❑ Do not place exposed media directly on the floor. Media should be rewound and inserted in its original packaging for storage.

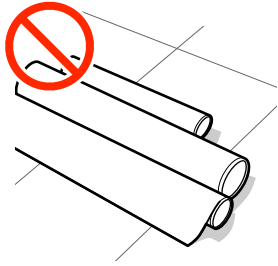

- ❑ Do not carry media with the media surface pressed against clothing. Handle media in its individual packaging until just before loading the media in the printer.

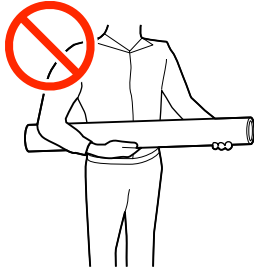

- ❑ Do not store the media uncovered. Otherwise, the edges of the media may become wavy or curled resulting in the media coming into contact with the print head during printing which could cause a malfunction to occur.
- ❑ Leaving media in the printer for extended periods may cause it to deteriorate.

## Handling Media After Printing

To maintain long lasting, high quality print results, note the following points.

- ❑ Do not rub or scratch the printed surface. If they are rubbed or scratched, the ink may peel off.
- ❑ Do not touch the printed surface, as this may remove the ink.
- ❑ Avoid direct sunlight.
- ❑ To prevent discoloration, display and store prints as instructed in the documentation supplied with the media.

## Introduction

# Introducing the Supplied Software

### Regions other than North America and Latin America

The following CD and software package is included with this printer.

- ❑ Software disc  
See the following table for descriptions of the software that has been supplied.
- ❑ Epson Edge Print (software package)  
Epson Edge Print is a software RIP that can be effortlessly used with easy-to-understand operations. This can be installed over the Internet. See the *Setup Guide* (booklet) for how to install the software.

## Supplied software

The following table shows the software supplied.



Windows versions are provided on the software disc supplied. If you are using a Mac or a computer without a disc-drive, you can download and install the software from the following link: <http://epson.sn>.

For information about the software, see the on-line help for the application or the *Network Guide* (Online Manual).

**Note:**

*Printer drivers are not provided. A software RIP is required for printing. The Epson Software RIP, "Epson Edge Print", is included with this printer on a separate CD.*

*The Epson Web site provides supported plug-in software for the printer.*

Software Name	Summary
Epson Edge Dashboard*	<p>After installation, it operates as resident software. Hands off or updates the print settings file (EMX) in Epson Edge Print, and sends notifications on the status of registered printers. You can also perform the following control operations for supported Epson printers.</p> <ul style="list-style-type: none"> <li>❑ You can easily acquire the following variety of information provided by Epson on the internet. <ul style="list-style-type: none"> <li>❑ Print settings files (EMX)</li> <li>❑ Update information for the printer firmware (you can update the firmware easily from Epson Edge Dashboard)</li> <li>❑ Update information for software and manuals installed from the supplied software disc and Epson Setup Navi (When you receive an update information, you can quickly update the software by starting EPSON Software Updater.)</li> <li>❑ Information from Epson</li> </ul> </li> <li>❑ You can monitor the status of the printer connected to a computer with Epson Edge Dashboard installed over a network or USB connection.</li> <li>❑ You can easily make and change media settings from a computer and write to the printer.</li> </ul> <p> <a href="#">"Starting Procedure" on page 32</a></p> <p> <a href="#">"Closing Procedure" on page 33</a></p>
EPSON Software Updater	<p>The software checks if new software or update information is available on the Internet and installs it. You can also update the manuals, Epson Edge Dashboard, and Epson Edge Print for this printer.</p>

## Introduction

Software Name	Summary
Epson communications drivers (Windows only)	Epson communications drivers is required when using Epson Edge Dashboard, Epson Edge Print and when connecting a computer to the printer via USB. Make sure these are installed.
EpsonNet Config SE	With this software, you can configure various network settings for the printer from your computer. This is useful as it allows you to enter addresses and names using the keyboard.

\* Download and install the software from the Internet. Connect your computer to the Internet and install the software.

### North America

To view and download software options, visit the support site for your region and search for your product:

- ❑ <https://www.epson.com/support> (U.S.)
- ❑ <http://www.epson.ca/support> (Canada)

### Latin America

To view and download software options, visit the support site for your region and search for your product:

- ❑ <http://www.latin.epson.com/support> (Caribbean)
- ❑ <http://www.epson.com.br/suporte> (Brazil)
- ❑ <http://www.latin.epson.com/soporte> (other regions)

---

## Pre-installed software

This software is pre-installed on the printer. You can start it from a web browser via a network.

Software Name/ Function	Function
Web Config	<p>This software is for network administrators.</p> <p>The network security settings can be configured from Web Config. It also provides an e-mail notification function to inform you when errors and so on occur in the printer.</p> <p> <a href="#">"Using Web Config" on page 44</a></p>

## Introduction

# Using Epson Edge Dashboard

This section explains the basic operations of Epson Edge Dashboard. The software supplied with the printer is updated as needed to make it more useful and to improve functions. See the software help for the latest details.

## Starting Procedure

Epson Edge Dashboard is a Web application.

- 1 The application can be launched using either of the following two methods.

### Windows

- ❑ Click the **Epson Edge Dashboard** icon on the Desktop toolbar and select **Show Epson Edge Dashboard**.

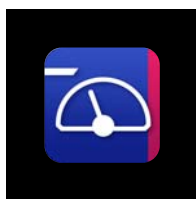

- ❑ Click **Start-All Programs (or Programs)-Epson Software-Epson Edge Dashboard**, in this order.

### Mac

- ❑ Click the **Epson Edge Dashboard** icon on the menu bar of the Desktop and select **Show Epson Edge Dashboard**.



### Linux

Click **Applications-Other-Epson Edge Dashboard**.

- 2 Epson Edge Dashboard starts.

## Registering the Printer

The Epson Edge Dashboard can monitor, manage, and copy media settings to registered printers.

On Windows computers, printers are registered automatically. This allows you to monitor and manage them immediately after starting the Epson Edge Dashboard. If your printer is not automatically registered, check that you are using it under the following conditions, and then register it manually.

- ❑ A communication driver provided with the printer has been installed on a computer
- ❑ The computer and printer are connected
- ❑ The printer is on standby

Printers are not registered automatically for Mac or Linux. Register your printer manually from the Register Printer screen. This screen is displayed when you start Epson Edge Dashboard for the first time.

### Manual registration procedure

- 1 Check the printers displayed on the printer list.

#### Windows

Make sure that the printer you want to register is on the printer list. Click **Add Search** as needed to search for printers you can register. Any printers that are found are added to the printer list.

#### Mac/Linux

- ❑ If your computer and printers are connected via USB  
Click **Add Search** to place the printers on the list.
- ❑ If your computer and printers are connected via a network  
Click **Search Option**, enter the IP address of the printer on the network, and click **+**. Next, click **Add Search** to place the printer you want on the list.

- 2 Place a ✓ beside the **Printer Name** of the printer you want to register.

- 3 Click **Apply**.

The changes made to the printer list are applied.



## Introduction

# Checking and Managing the Printer's Status

**1** In the Home screen, click the area surrounding the printer that you want to check.

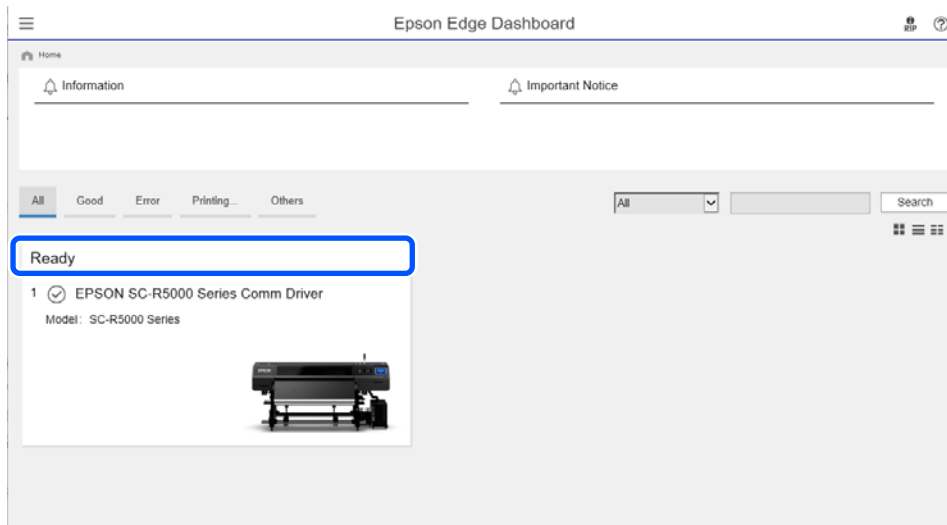

**2** Make sure that the **Printer Status** tab (1) is selected.

The Printer Operation screen is displayed. Understanding the status icons for consumables is the same as for the icons on the printer's control panel screen.

When multiple printers are registered with this software, you can switch the printer being monitored in the registered printers list (2).

You can execute some maintenance functions from this software by clicking the buttons (3) at the bottom of the screen. The content executed is the same as from the printer's Settings menu.

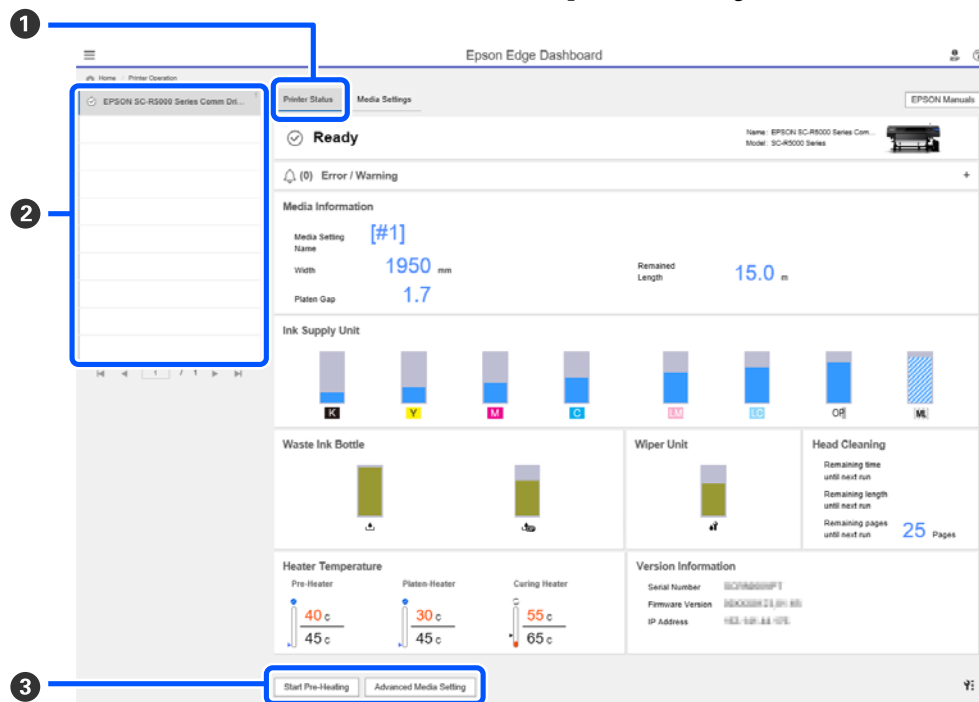

## Closing Procedure

Close the Web browser. However, since Epson Edge Dashboard is a resident software, it does not stop running.

## Introduction

# Using Epson Edge Print

This section explains the basic operations of Epson Edge Print. The software supplied with the printer is updated as needed to make it more useful and to improve functions. See the software help for the latest details.

## Configuration of main screen





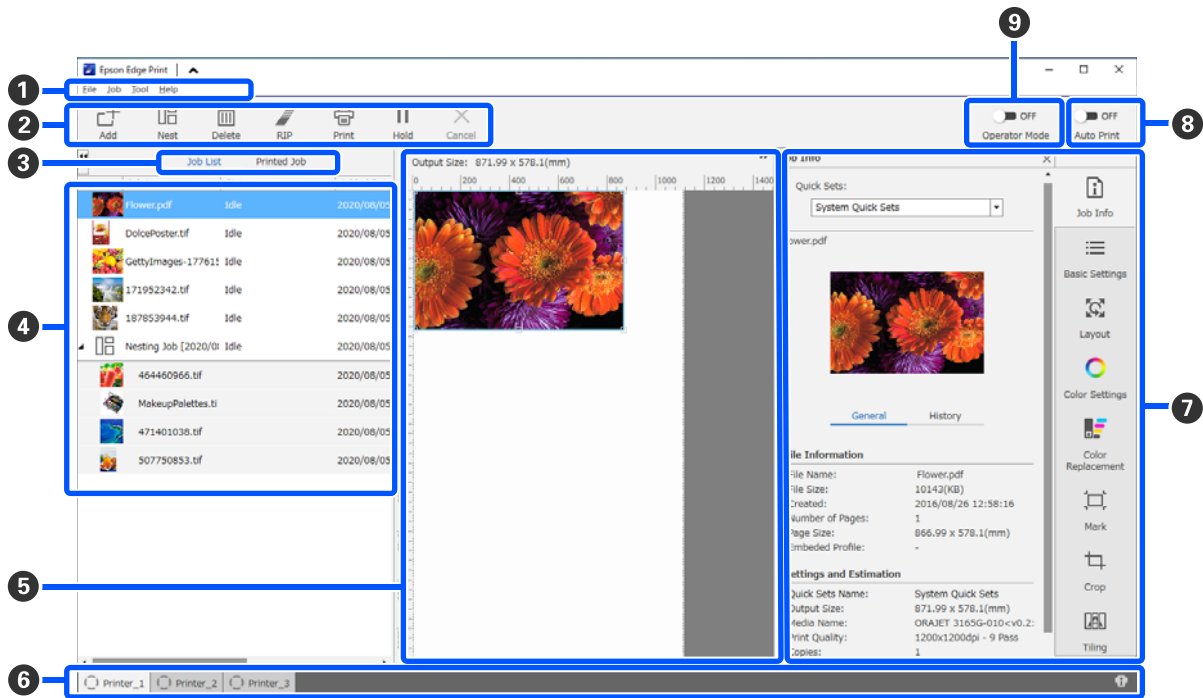

















The following main screen appears when you start Epson Edge Print.

The configuration and functions of the main screen are shown below.



	Names of parts	Function
1	Menu bar	You can do settings and operations in the various menus. By clicking ^ or v in the title line, you can show or hide the menu bar.

## Introduction

	Names of parts	Function
2	Job toolbar	<p>You can perform the following operations for jobs that you select in the Job List/Printed Job lists (4).</p> <p>: Select and add print data to the Job List.</p> <p> / : Create a single nest job from multiple jobs that you select.</p> <p>When you select a nest job,  changes to  and you can do UnNest.</p> <p>: Delete selected jobs from the list.</p> <p>: Do only RIP processing to selected jobs.</p> <p>: Do RIP while printing selected jobs. When you select a job for which RIP is already complete, only printing is done.</p> <p>: Stop printing or RIP processing that is being executed.</p> <p> / : Put the selected job on hold. Held jobs are not printed when you set the Auto Print switching button (3) to  ON to perform auto printing.</p> <p>When you select a job being held,  changes to  and you can cancel the hold. If you cancel a hold during automatic printing, the job becomes idle and is printed at the end of the queue.</p>
3	List switching button	<p>Switch the Job List/Printed Job Lists.</p> <p>The name of the currently selected list is shown in a frame.</p>
4	Job List/Printed Job Lists	<p>In the Job List, a thumbnail, name of the source data, and the status are shown for jobs that are printing or waiting to be printed. Jobs that are finished printing are automatically moved to the Printed Job list.</p>
5	Preview area	<p>You can check a preview of a job that you select in the Job List (4).</p> <p>The white area shows the media. The width of the media changes according to the settings in  (Basic Settings) - <b>Media Size</b> in the Job Settings menu. The distance from the left and right edges of the media to the dotted lines are the margins.</p> <p>You can also drag the preview image to change the printing position.</p> <p>By clicking  or  at the bottom of the preview area, you can reduce or enlarge the preview area display.</p>
6	Switch printer tab	<p>Shows the status and name of printers that are registered in this software.</p> <p>Click a tab to change the printer to operate. The white tab is the printer that is currently being operated.</p> <p>The meanings of the status icons is as follows.</p> <p>: Printing is possible (ready).</p> <p>: Currently printing.</p> <p>: Warning or something has occurred.</p> <p>: Error has occurred.</p> <p>: Currently performing an operation other than printing, such as Print Head Cleaning or operating the control panel.</p> <p>: The power is off or not connected.</p>
7	Job Setting menu & Setting area	<p>Perform settings, such as printing, layout, and Input/output profile, for idle jobs that are selected in the Job List (4).</p> <p>The icons on the right are the Job Setting menu. The content of the setting area changes depending on the items that are selected.</p>

## Introduction

	Names of parts	Function
8	Auto Print switching button	<p>Each time this button is clicked, it turns on or off.</p> <p>By setting it to <input checked="" type="checkbox"/> ON , the print jobs start printing in order just by adding print data to the Job List (4). When there are idle jobs in the Job List, idle jobs are also printed in order.</p> <p>By setting it to <input type="checkbox"/> OFF , the jobs are not printed until after the print data is added to the Job List, selected, and then printed.</p> <p>When multiple jobs are put together and nesting or RIP is done before printing, set <input type="checkbox"/> OFF to do the nesting and RIP work, and then change it to <input checked="" type="checkbox"/> ON .</p>

## Introduction

### Printing with the appropriate settings for the media being used (printing using EMX)

You must register the print information and the media setting values that are appropriate for the media you are using to the printer and the Epson Edge Print to print correctly on the media you are using.

This is because media has various unique characteristics. For example, there is media that needs large amounts of ink or that requires time to dry. If you do not print with the settings that match the media, the print results will not be satisfactory.

However, to do the settings to get the optimum printouts on the media you are using by finding the optimum values for each of the multiple setting items is complicated, and requires an extreme amount of time and work.

Here, we use the print files (EMX files) provided free from Epson to explain a method to easily print and get the print quality of the expert settings.

### Preparing to print

#### Checking the operating environment

Check the following points.

- The printer and Epson Edge Print are connected correctly, and the power is on.
- The computer on which the RIP server (Epson Edge Print) is installed is connected to the Internet.
- Epson Edge Print is running.
- The printer is registered in Epson Edge Print.
- Media is loaded in the printer and it is ready to print.

#### Preparing the print data

Prepare print data in a data format that is compatible with Epson Edge Print.

For details on supported data formats, see the Epson Edge Print help.

Generally, we recommend PDF for the following reasons.

- There are no broken links to images or disrupted layouts.
- Text does not need to be outlined.
- The appearance does not change, even for different versions of image processing software.

### Preparing EMX files

An EMX file is a print settings file for each media type and includes the following information that is necessary to print appropriately on commercially available media.

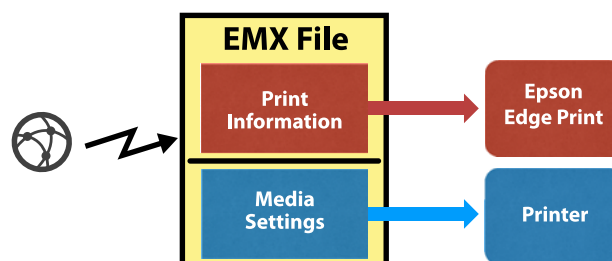

#### Print Information

The settings that are registered in Epson Edge Print, such as the media's ICC profile, number of passes, and resolution.

#### Media Settings

The settings that are registered to the printer's Media Management for the heater temperature, Platen Gap, Feeding Tension, and so on, that are appropriate for the media you are using.

In this section, we explain the procedure to acquire and register EMX files in Epson Edge Print.

To acquire an EMX file, the RIP server must be connected to the internet.

- 1 Click Tool menu - **Manage Preset** - (Manage Print Info) in this order.

The screen changes to the Manage Print Info screen.

- 2 Click (Add).

Adding Print Information starts.

## Introduction

**3** Select **Acquire EMX File** and click **Proceed**.  
A list of the EMX files provided for free by Epson is displayed.

**4** Select the EMX file that is compatible with the media you are using.

Select one EMX file. You cannot select multiple EMX files at one time.

The EMX files that you have already acquired are greyed out and cannot be selected.

The ones that show **Update Available** in **Status** indicate that an EMX has been updated after you acquired it.

If you select and acquire an EMX that shows **Update Available**, the file that was already acquired is overwritten.

**5** Click **Proceed**.

You can copy the media setting value for the acquired EMX file to the printer. To copy the file, select **Copy Media settings** and proceed to step 6.

If you are not copying the file, then proceed to step 7.

**6** Select where to copy the media setting values within the EMX file, and then click **Execute**.

The media numbers (1 to 50) that are registered to the selected printer are displayed. Specify where to copy the media setting values (media numbers) within the EMX file acquired in step 4.

Selecting a number that is blank adds the values. Selecting a number that has already been registered overwrites the registered information.

**7** Click **Finish**.

Acquisition and registration are done.

When registration is finished, the registered print information is added to the print information list.

Print information is identified by the media name.

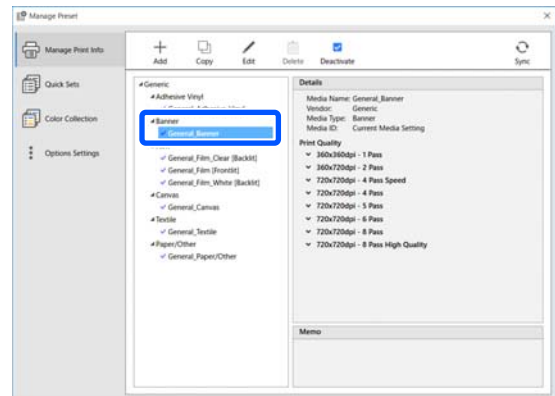

The  on the left of the media name indicates that it is enabled. You can select enabled print information by using its **Media Name** in  (Basic Settings) in the Job Settings menu. If there are so many items displayed for a **Media Name** that it becomes difficult to choose, select print information that is not needed on this screen, and then click  (Deactivate). The  on the left side of the media name disappears and the print information is disabled.

You can customize settings based on acquired print information or create new print information.

See the Epson Edge Print help for detailed information about editing and adding print information.

## Preparing the printer

After copying the media settings for the acquired EMX file to the printer, perform Print Adjustments from the printer's Settings menu.

Print Adjustments optimizes the media settings to correct individual differences in your media and printer so that you can perform optimal printing using your media and printer combination.

If you do not execute Print Adjustments, banding or graininess may appear in the print results.

**1** Load the media you are actually using on the printer.

When you have finished loading the media, the settings screen for the media you have loaded is displayed on the control panel screen.

## Introduction

- 2 Select the number selected in step 6 from "Preparing EMX files".  
When the media information settings are complete, the home screen is displayed.  
Check that the specified media number is displayed, and that the message **Ready to print.** is displayed.

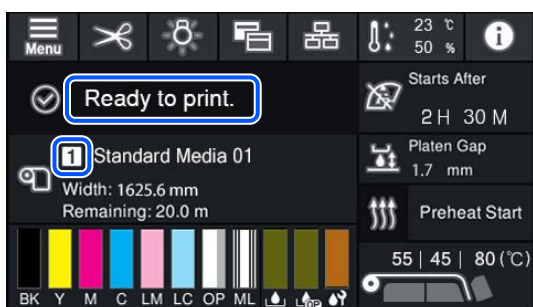

- 3 Execute **Print Adjustments** in the Settings menu.  
See the following for a detailed procedure.  
[🔗 “Optimizing Media Settings \(Automatic Adjustment\)” on page 61](#)

## Printing procedure

- 1 Click (Add) in the Job toolbar and add the print data to the Job List.  
Or, drag and drop the print data onto the Job List.  
The name of the data and a thumbnail for the print data that was added appear in the Job List.

**Note:**

When you click (Add) and select the print data, you can also select Quick Sets at the same time.



Quick Sets are a saved batch of print job settings. Jobs are generated according to these settings.

For details on Quick Sets, see the Epson Edge Print help.

- 2 Select a job to print from the Job List.  
An image of the printout appears in the preview area.
- 3 Click (Basic Settings) in the Job Setting menu.  
The setting area changes to Basic Settings, and you can set the media size, media name (print information), and print quality (resolution and number of passes).  
For details, see the Epson Edge Print help.
- 4 Click (Print) in the Job toolbar to start printing.

### To print large jobs

While it depends on the performance of your server, with large jobs, such as long jobs or nested jobs, the print heads may stop and start during printing. In this situation, we recommend performing RIP processing before printing.  
For details, see the Epson Edge Print help.

### When you want to print jobs in order in batches

When there are multiple jobs in the Job List, you can decide on an order and then specify batch printing.  
When you have specified batch printing, you can sort the Job List in the order for printing.  
For details, see the Epson Edge Print help.

During printing, **Printing** appears in the **Status** column in the Job List. A progress bar for the remaining print time also appears in the preview area.

**Note:**

Check the status of the switch printer tab before starting to print. You cannot print if the status icon is one of the following.

: Error has occurred.

: Currently performing an operation other than printing, such as Print Head Cleaning or operating the control panel.

: The power is off or not connected.

Prepare the printer for printing.

Jobs that are finished printing are automatically moved to the Printed Job list.

## Introduction

See the Epson Edge Print help for details on how to use the Printed Job list.

Use the Job Setting menu to enlarge or reduce jobs, to print only a portion of an image, or to print an image that is wider than the media.

For details, see the Epson Edge Print help.

### Stopping printing

Use the following procedure if you want to stop printing while a job is printing.

- 1 Select the job to stop printing from the Job List, and click  (Cancel) in the Job toolbar. Or, open the right click menu on the name of the job to stop printing and select **Cancel**.
- 2 When the confirmation screen appears, click **Yes**.

### Dividing a large image into parts to print it (tiling)

This section explains the typical features of Epson Edge Print.

When printing a large image that is wider than the media on which you are printing, you can divide the large image into several parts and print it on the media.

You can also add overlaps for pasting so that after printing the image can be pasted together into one image.

The procedure for dividing an image is explained below.

### How to divide an image

- 1 Select a job to divide from the Job List.
- 2 Click  (Tiling) in the Job Setting menu. The setting area changes to Tiling settings.
- 3 Select **Enable Setting**. The settings items are enabled.

- 4 Set the size of the divisions in **Tiling Setting**. Each of the divided images are called “tiles”.

To set the number of pieces in which to divide the image, select **Specify by Number of Tiles**.

To set the size of tiles and then divide the image, select **Specify by Tile Size**.

To set the number of tiles, advance to step 5.

To set the size of tiles, advance to step 7.

- 5 Set how many divisions to make in **Number of Tiles**.

Example: 3 divisions in Horizontal

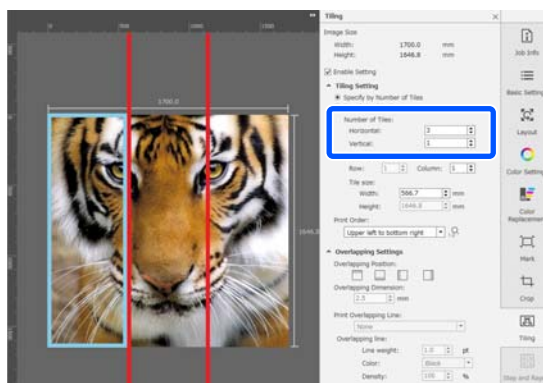

Example: 2 divisions in Horizontal and Vertical

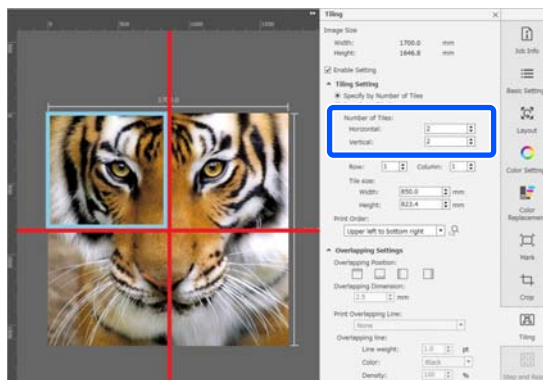

- 6 You can make fine adjustments to the size of tiles that you are dividing.

If you want to avoid generating a pasted edge in any position, such as where the eye is located in the example of 3 divisions in Horizontal in step 5, use the following procedure to select the upper left tile and adjust the tile size.



**Introduction**

- (1) Use the mouse cursor to click the tile you want or specify the position of the tile you want in **Tile to Specify Size**.

The tile targeted to be adjusted is indicated by a light blue frame.

- (2) To adjust the size, drag the light blue frame or enter a value in **Tile size**.

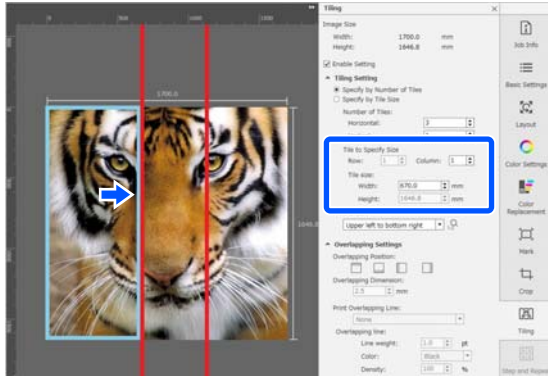

Advance to step 8, and set the overlap.

- 7** Set the size of divisions in **Specify by Tile Size**.  
Example: Set to A2 size

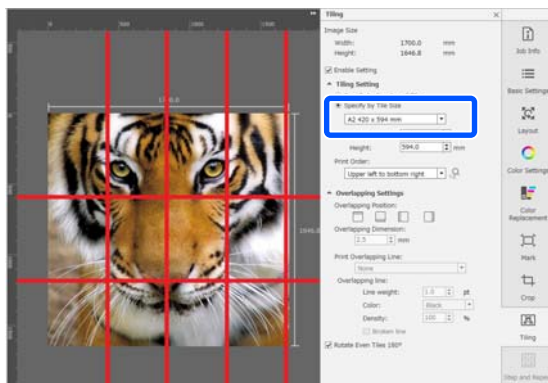

Example: Set to Width 1000 mm and Height 700 mm in User Defined

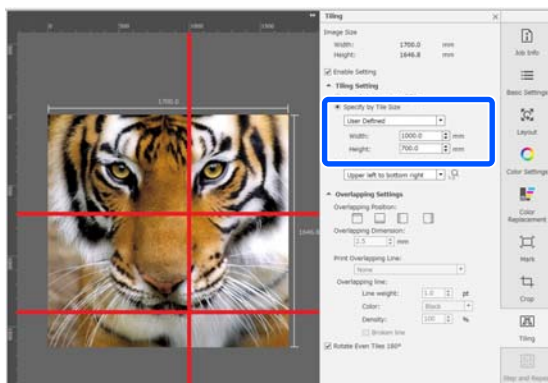

- 8** Set the order in which tiles are printed in **Print Order**.

When you select **Print Order** and then click , a number indicating the print order is displayed on each tile in the preview area.

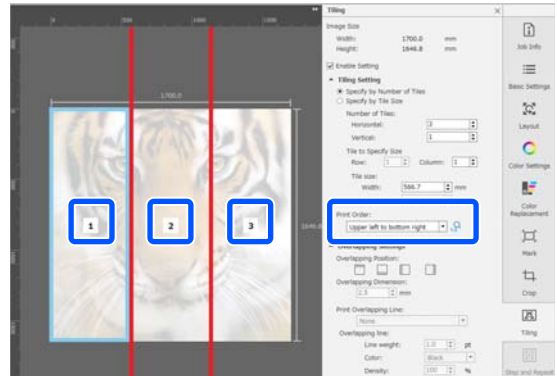

- 9** Set the overlap for pasting the images together in **Overlapping Settings**.

- (1) Set where to set the overlap in **Overlapping Position**.
- (2) Set the width of the overlap in **Overlapping Dimension**.

Example: **Overlapping Dimension** is 10 mm and the **Overlapping Position** is on the left side

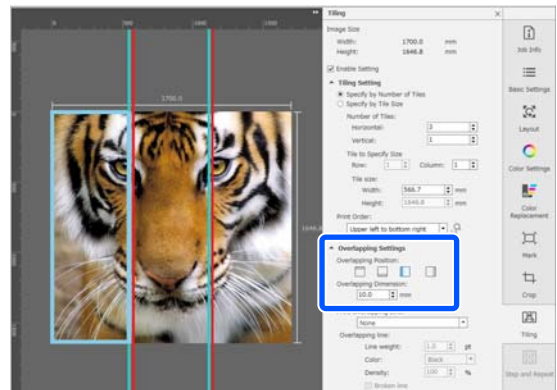

If you want to print boundary lines between the image and the overlap, go to step 10.

If you do not want to print boundary lines between the image and the overlap, go to step 11.

- 10** In **Print Overlapping Line**, select **Print on Image and Margins** or **Print only on Margins**.

Boundary lines are printed between the image and the overlap and can be used as guides to paste the image together.

## Introduction

You can use **Overlapping line** to change the thickness, color, and density of the boundary lines to make them easier to see. If you select **Broken line**, you can change the boundary line from a solid to a broken line.

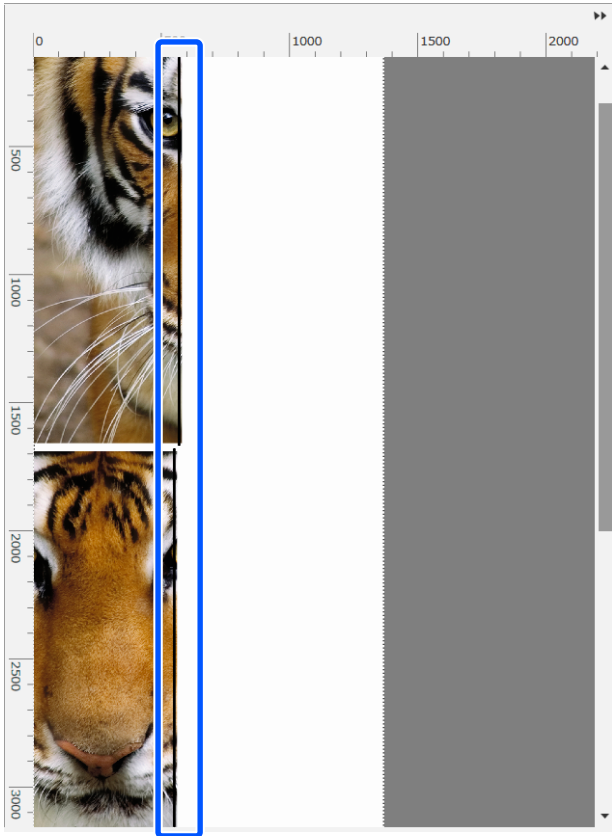

Example: **Print on Image and Margins** is set

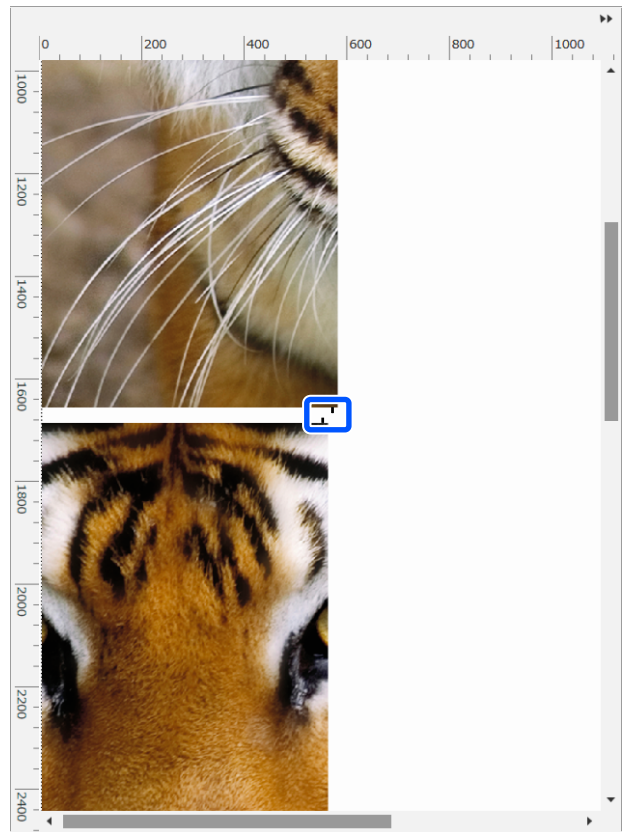

Example: **Print only on Margins** is set



11

When the settings for dividing the image are complete, select something other than  (Tiling),  (Color Replacement), or  (Crop) in the Job Settings menu to change the preview area into the print preview.

Example: When  (Job Info) is selected

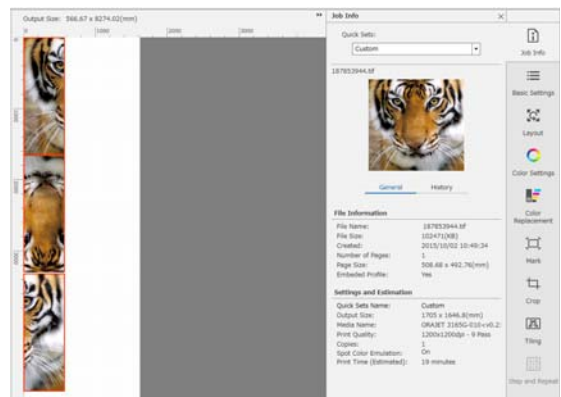

## Introduction

**Note:**

Click  (Layout) in the Job Settings menu to change the tile arrangement.

For example, you can reduce wasted media by arranging tiles horizontally that were initially arranged vertically to match the width of the media, and then printing.

However, depending on the arrangement of the tiles, there may be color deviation at the seams when the images are pasted together.

### When not printing a specified tile

You can cancel printing with the following procedure when you do not want to print a specific tile after an image is divided in the **Tiling** settings.

- 1 Open the right click menu on the tile not to print.
- 2 Clear the **Print** checkbox.  
When you clear the **Print** checkbox, an icon is displayed on the tile.  
Select the checkbox to print the tile.

**Note:**

If you right-click on a tile and select **Clear All** from the menu displayed, none of the tiles are printed.

If you only want to print one tile, right-click on the tile you want to print, select **Clear All** from the menu displayed, and then select **Print**.

### When color deviation at the seams stands out

When images are pasted together and the color deviation at the seams is conspicuous, check if the **Rotate Even Tiles 180°** checkbox in the **Tiling** settings is cleared.

When this is selected, the tiles are alternately printed top to bottom so the discoloration becomes less conspicuous.

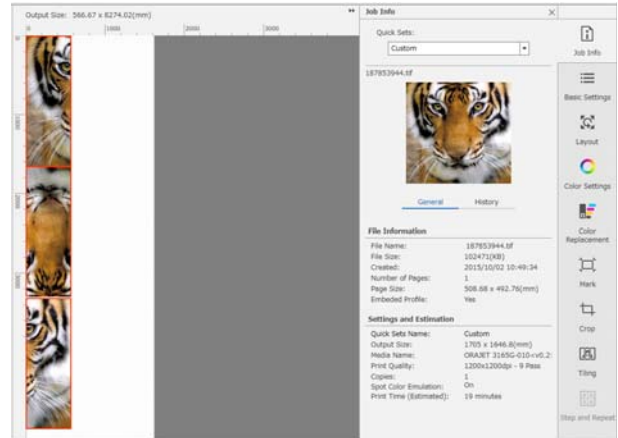

You can also improve the issue of color deviation by setting **Print Head Warm Up** to **On** in the printer's settings menu.

 [“Media Management items” on page 114](#)

## Introduction

# Using EPSON Software Updater

**Note:****North America**

To check for software updates, visit:

- <https://www.epson.com/support> (U.S.)
- <http://www.epson.ca/support> (Canada)

**Latin America**

To check for software updates, visit:

- <http://www.latin.epson.com/support> (Caribbean)
- <http://www.epson.com.br/suporte> (Brazil)
- <http://www.latin.epson.com/soporte> (other regions)

## Checking software update availability

- 1 Check the following status.
  - The computer is connected to the Internet.
  - The printer and the computer can communicate.

- 2 Start EPSON Software Updater.

**Windows 8.1/Windows 8**

Enter the software name in the search charm, and select the icon displayed.

**Except for Windows 8.1/Windows 8**

Click Start > **All Programs** (or **Programs**) > **Epson Software** > **EPSON Software Updater**.

**Mac OS X**

Click **Go - Applications - Epson Software - EPSON Software Updater**.

**Note:**

In Windows, you can also start by clicking the printer icon on the desktop toolbar and selecting **Software Update**.

- 3 Update the software and manuals.  
Follow the on-screen instructions to continue.

**! Important:**

Do not turn off the computer or printer while updating.

**Note:**

Software that is not displayed in the list cannot be updated using EPSON Software Updater. Check for the latest versions of the software from the Epson Web site.

<https://www.epson.com>

## Receiving update notifications

- 1 Start EPSON Software Updater.
- 2 Click **Auto update settings**.
- 3 Select an interval for checking for updates on the printer's **Interval** box, and then click **OK**.

## Using Web Config

Provides an overview of starting the software and the functions provided.

## Starting Procedure

Start the software on a computer that is connected to the same network as the printer.

- 1 Check the printer's IP address.  
Confirm that the printer is ready to print. Press  (menu), and then select **General Settings - Network Settings - Wired LAN Status**.
- 2 Start a Web browser on the computer that is connected to the printer over the network.

**Introduction**

**3** Enter the IP address of the printer in the address bar of the Web browser and press the **Enter** or **Return** key.

Format:  
 IPv4: http://IP address of printer/  
 IPv6: http://[IP address of printer]/

Example:  
 IPv4: http://192.168.100.201/  
 IPv6: http://[2001:db8::1000:1]/

---

**Closing Procedure**

Close the Web browser.

**Uninstalling Software**

 **Important:**

- Log into a "Computer administrator" account (an account with Administrator privileges).
- Enter the administrator password when prompted and then proceed with the remainder of the operation.
- Exit any other applications that may be running.

**Windows**

This section describes how to uninstall Epson Edge Dashboard and the Epson communications drivers using them as an example.

- 1** Turn off the printer, and disconnect the cable from the computer.
- 2** On the computer on which the software is installed, click **Control Panel**, and then click **Uninstall a program** from the **Programs** category.
- 3** Select the software you want to remove and then click **Uninstall/Change** (or **Change/Remove**).  
 Selecting the following deletes the Epson communications drivers. The model number appears in XXXXX.
  - EPSON SC-RXXXXX Series Comm Driver Printer Uninstall

To uninstall **Epson Edge Dashboard**, select Epson Edge Dashboard.

- 4** Select the target printer icon, and then click **OK**.
- 5** Follow the on-screen instructions to continue.  
 When the delete confirmation message appears, click **Yes**.

If you are reinstalling the Epson communications drivers, restart the computer.

**Mac**

The following describes how to remove Epson Edge Dashboard.

- 1** Quit **Epson Edge Dashboard**.
- 2** Double-click **Applications - Epson Software - Epson Edge Dashboard - Epson Edge Dashboard Uninstaller**.  
 Follow the on-screen instructions to continue.

# Basic Operations

## Workflow for Correct Printing

Follow the instructions below to print correctly on your media.

### 1. Register media settings to the printer and print information to the RIP

Register the media settings to the printer based on the characteristics of your media, and register the print information in the RIP.

Epson provides an EMX file that combines media settings and print information for most major commercially available media.

You can easily perform the following operations in wizard format using the software RIP "Epson Edge Print" supplied with the printer.

- Download the EMX file
- Automatically register print information to Epson Edge Print
- Register media settings to the printer

See the following for details.

 ["Printing with the appropriate settings for the media being used \(printing using EMX\)" on page 37](#)



### 2. Set the RIP for jobs with a print length longer than three hours so that it is within three hours

The printer cannot print continuously for more than three hours. The print length that you can print within three hours depends on the number of passes set in the print quality of the RIP.

See the following for more information on the print length determined by the number of passes. Also, see the following for more information on making a job fit within three hours.

 ["Print Lengths by Pass Number and Creating a Job" on page 139](#)



### 3. Load media into the printer and make media settings

Load the media, select the number to which you registered the media settings in step 1, and then enter the media length.

 ["Loading media" on page 47](#)

 ["Settings for Loaded Media" on page 53](#)



### 4. Attach the media to the Auto Take-up Reel Unit

To print while winding up the media, you need to attach the media to the Auto Take-up Reel Unit.

 ["Using the Auto Take-up Reel Unit" on page 55](#)



### 5. Optimize the media settings (when using new media)

Perform this once before using the media settings registered to the printer in step 1.

Optimize the media settings (Print Adjustments) to correct individual differences in your media and printer so that you can perform optimal printing using your media and printer combination.

 ["Optimizing Media Settings \(Automatic Adjustment\)" on page 61](#)



### 6. Check the status of the printer

Before starting work, check the amount of ink remaining and the status of the nozzles for the print head.

 ["Before Printing" on page 67](#)



### 7. Print

Start printing using the RIP.

See the following for details on printing using the software RIP "Epson Edge Print" supplied with the printer.

 ["Printing with the appropriate settings for the media being used \(printing using EMX\)" on page 37](#)

## Basic Operations

## Notes on loading media

When storing and handling media, be sure to observe the following points to keep the surface of the media free of dust and lint. Using media when there is dust or lint on it can cause nozzles to clog and ink to come off in the print results.

See the following for more information on handling and storing media.

 [“Precautions When Handling and Storing Media” on page 28](#)

### Do not place exposed media directly on the floor.

Media should be rewound and inserted in its original packaging for storage.

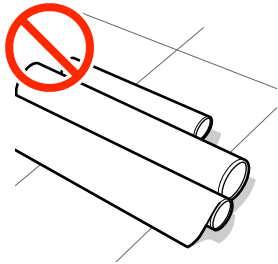

### Do not carry media with the media surface pressed against clothing.

Handle media in its individual packaging until just before loading the media in the printer.

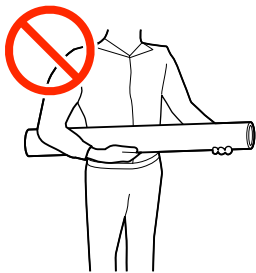

## Notes on Loading Media

### **Caution:**

- The curing heater, heaters, and media edge plates may be hot; observe all necessary precautions. Failure to observe the necessary precautions could result in burns.*
- Because the media is heavy, it should not be carried by one person.*
- Be careful not to trap your hands or fingers when opening or closing the printer cover. Failure to observe this precaution could result in injury.*
- Do not rub your hands along the edges of the media. The edges of the media are sharp and can cause injury.*

### Load the media just before printing.

Media left in the printer may also become wavy or curled, causing jams or resulting in the media coming into contact with the print head. This could cause the printer to malfunction or print quality to decline.

### Do not load media if the right and left edges are uneven.

If media is loaded and the right and left edges of the roll are uneven, media feeding problems may cause the media to move around during printing. Either rewind to align the edges or use a roll without any issues.

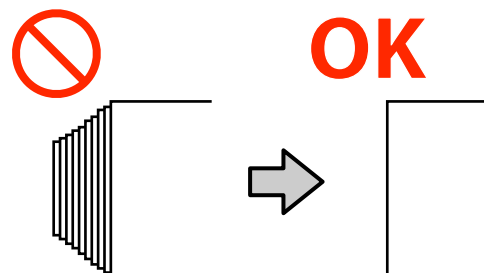

## Loading media

You can check the procedure in a video on YouTube.

[Epson Video Manuals](#)

### Basic Operations

- 1 Check that **Open Printer Cover and load the media.** is displayed on the home screen.
- 2 Open the printer cover, and then move the media loading lever to the back.

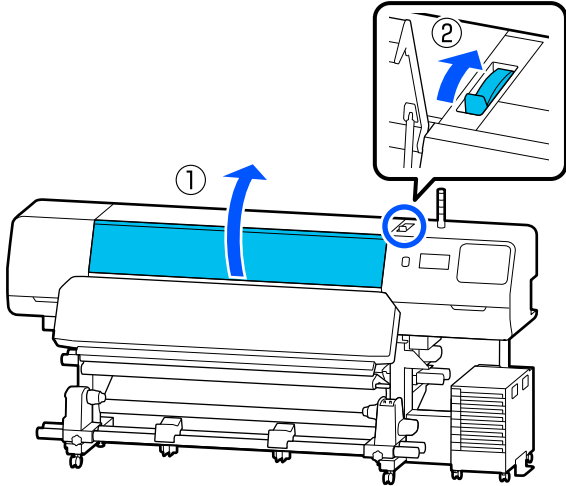

- 3 While holding the tabs of the media edge plates on both sides, move the plates to the edge of the media so that they are on the media.

If there is a thermal sheet on the platen, remove it before moving the media edge plates.

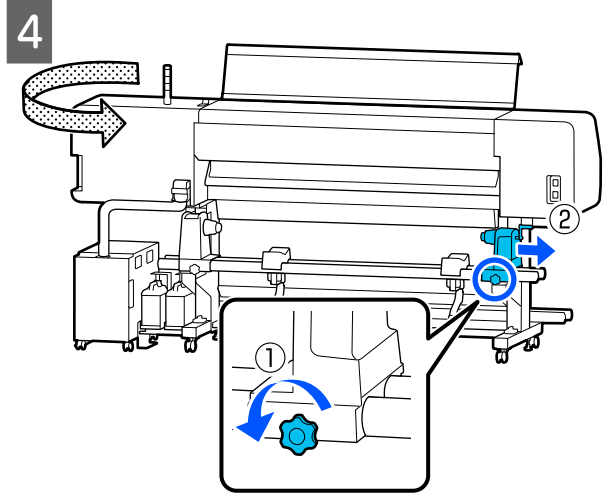
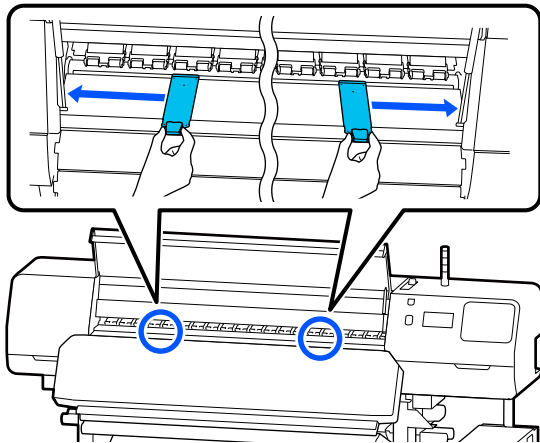

**! Important:**

*If the handle shaft for the right media holder is not visible, rotate the handle toward you until it stops. The media cannot be properly loaded if the handle shaft is not visible.*

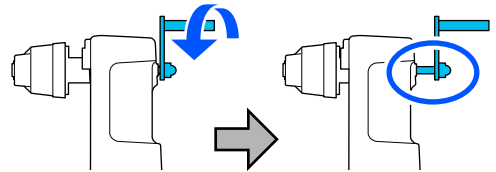

- 5 Loosen the fixing screw for the left media holder, and then move the media holder to the loading position according to the inner diameter of the roll core for the media you want to load.

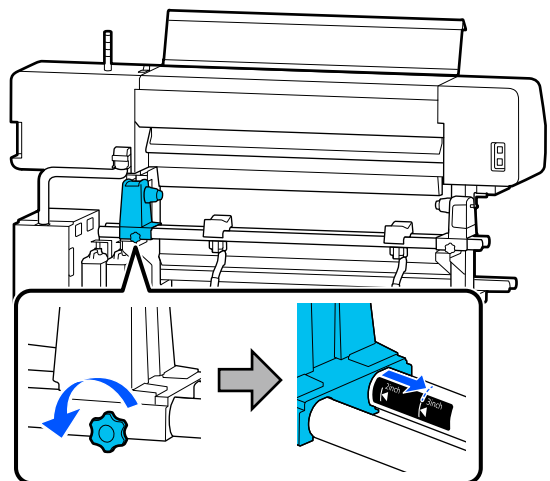



**Basic Operations**

**6** Tighten the screw until the screw no longer turns.

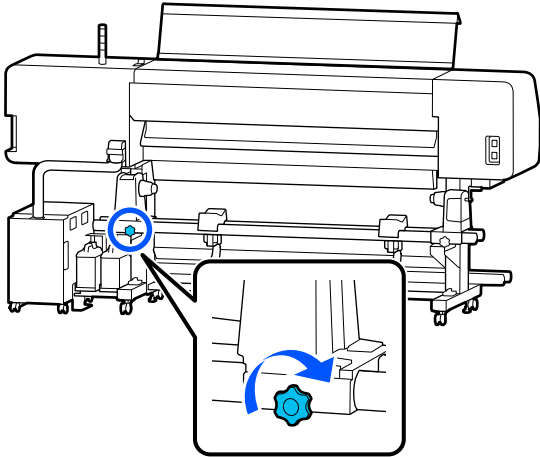

**7**

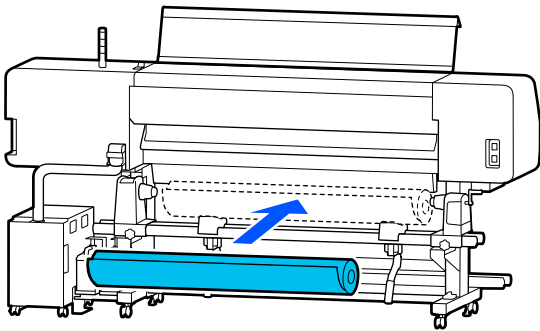

**Note:**  
The method of placing the roll media varies as follows depending on how media is rolled.

**Printable Side Out**

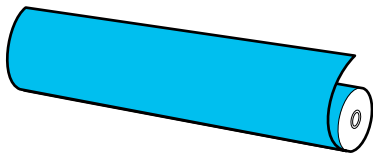

**Printable Side In**

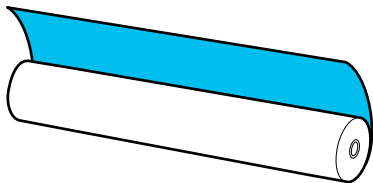

**8**

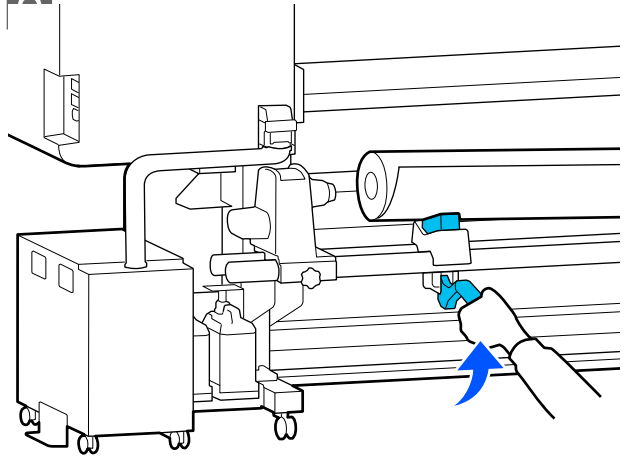

**9**

Firmly insert the roll core of the media onto the media holder.

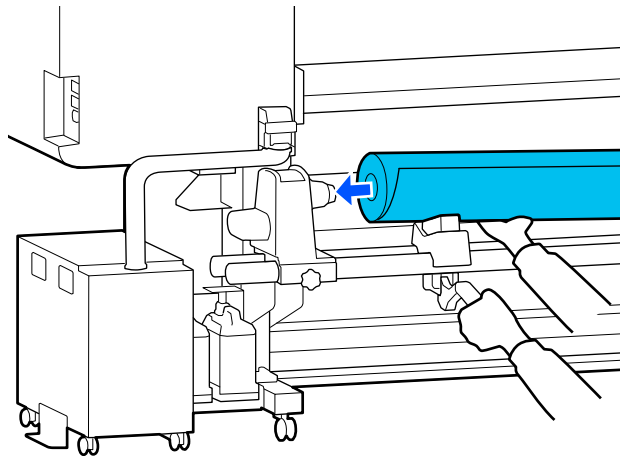

**Note:**  
If the roll of media has an outer diameter which is less than 140 mm (5.5 inches), the roll core will not reach the media holder when raised using the lift lever.

Raise it with your hands, and insert the roll core onto the media holder.

Basic Operations

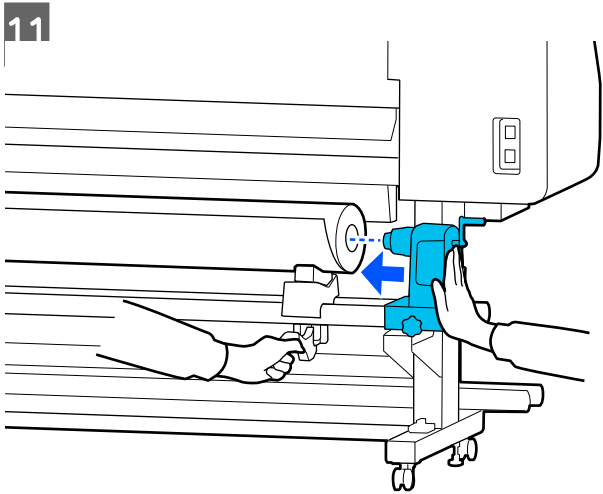
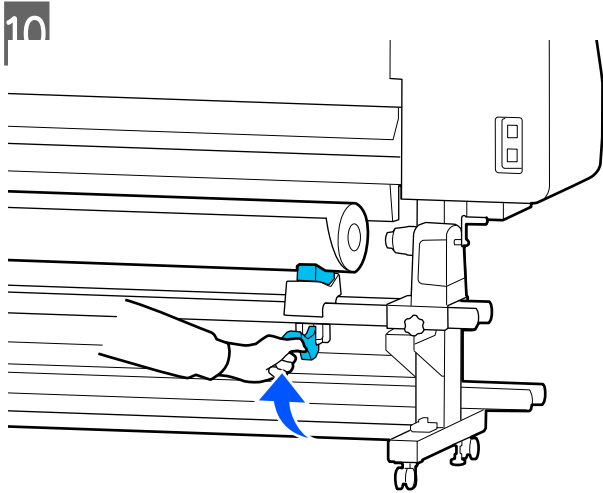

**Note:**  
 If the roll of media has an outer diameter which is less than 140 mm (5.5 inches), the roll core will not reach the media holder when raised using the lift lever.  
 Raise it with your hands, and insert the roll core onto the media holder.

**12** To ensure the media holder is inserted into the roll core sufficiently, push it twice.

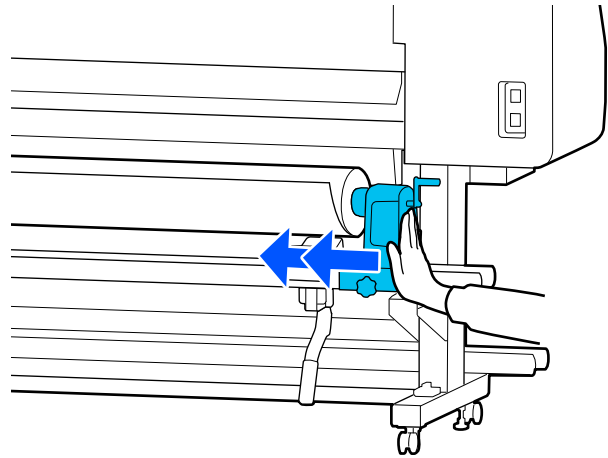

**! Important:**  
 If the media holder is inserted into the roll core insufficiently, media is not fed correctly during printing because of slippage between the media holder and the roll core.  
 This may cause banding in the print results.

**13** Tighten the screw until the screw no longer turns.

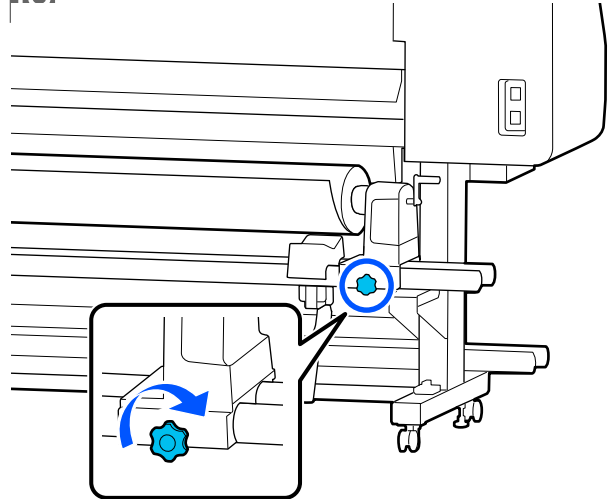

**! Important:**

- If the media holder screw is loose, the media holder may move during printing. This could cause stripes and unevenness in the print results.
- If the right and left edges of the roll are not aligned, realign them.

**Basic Operations**

- 14** Rotate the handle until part A in the illustration below is fully inserted.

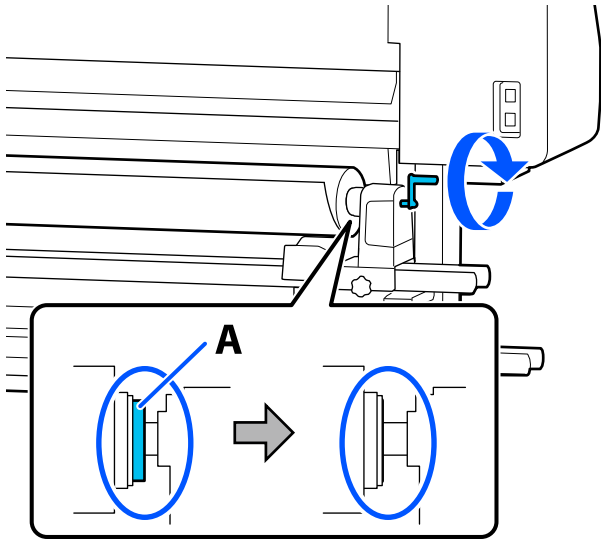

**! Important:**

Once part A is hidden, do not turn the handle any further. Failure to observe this precaution could damage the media holder.

If part A is still visible even after the handle has been turned fully, rewind the handle. Loosen the media holder screw on the right side, and then restart from step 4.

- 15** Insert the media approximately 30 cm (11.8 inches) into the opening.

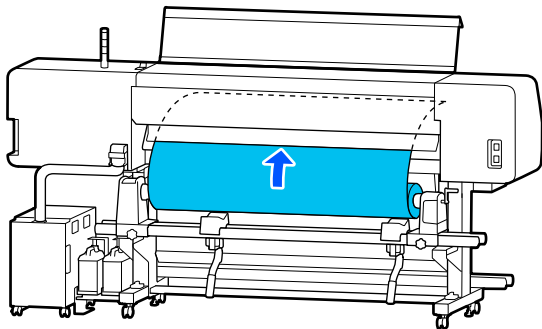

- 16** Confirm that the left edge of the media is within the range of the label's rectangle, as shown in the illustration below.

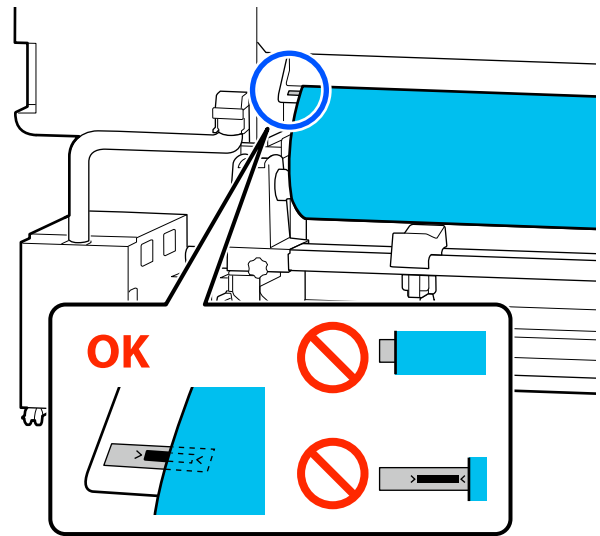

**Note:**

If the left edge of the media is not within the black square of the label, perform steps 4 to 16 in reverse to adjust the position of the media holder. Do not attempt to reposition the media holders while they are inserted in the media.

- 17** Move the media loading lever forward so that the inserted media does not slide out.

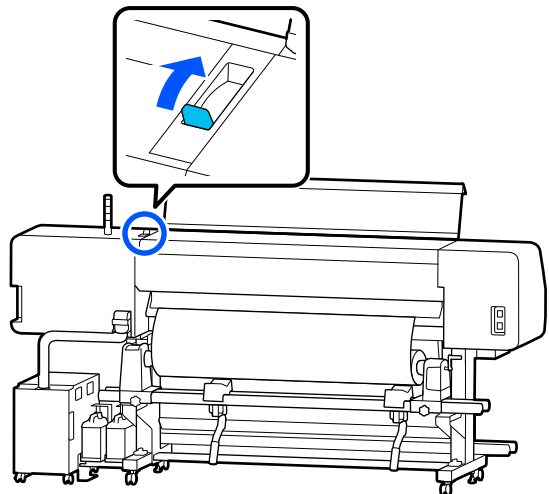

Basic Operations

18

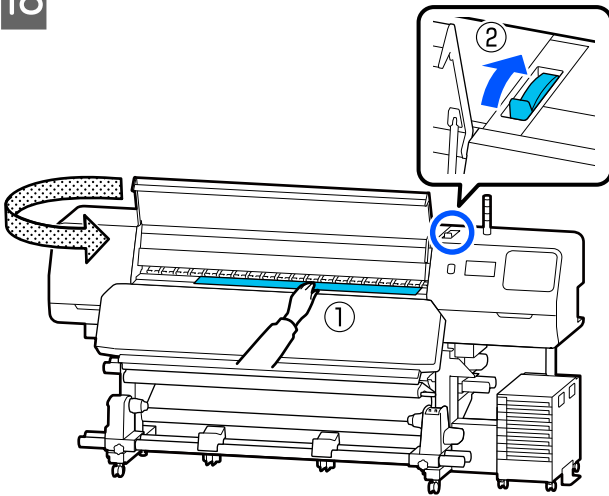

19

Hold the center of the media with one hand, and pull it straight out until the leading edge of the media enters the entrance of the curing heater.



**Important:**

*If the leading edge of the media is wavy or deformed by the heat, pull it all the way out of the front of the pressure rollers. If the pressure rollers press down on wavy or deformed areas, printing will not be performed correctly.*

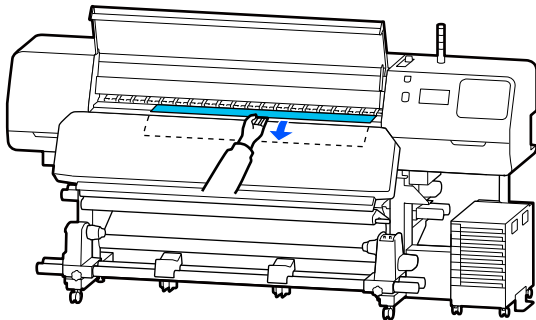

Do not pull the media with both hands. This could cause the media to skew or move around.

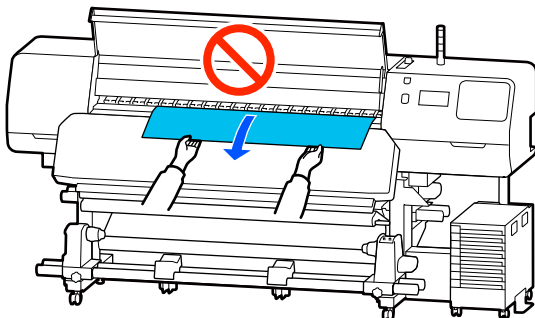

20

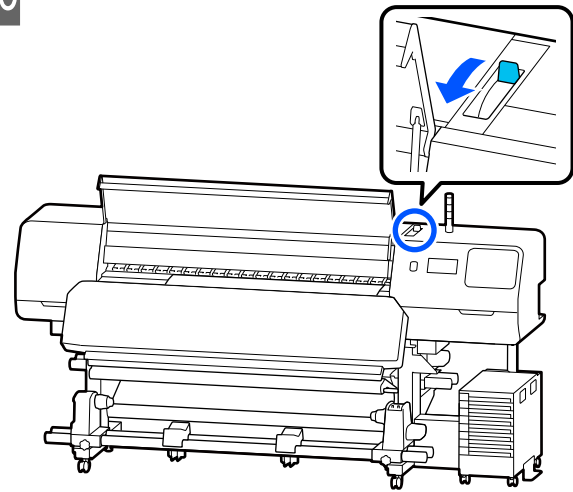

21

Tap lightly on both ends of the media, and check if there is a difference in tension between the left and right sides.

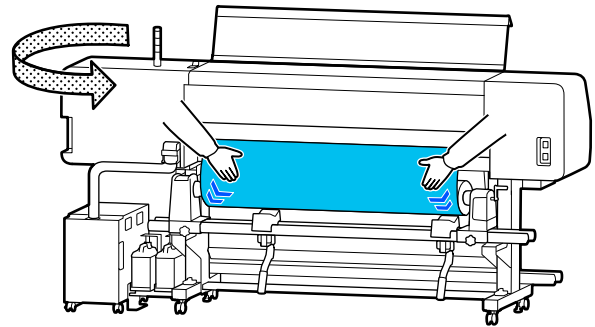

If there is a difference in tension, the media becomes loose.

From the front of the printer, move the media loading lever to the back, and correct any looseness in the media.

Once the looseness is corrected, move the media loading lever to the front.

## Basic Operations

- 22** While holding the tabs of the media edge plates on both sides, move the plates to the top edge of the media. Adjust so that the edges of the media are aligned with the center of the holes in the media edge plates.

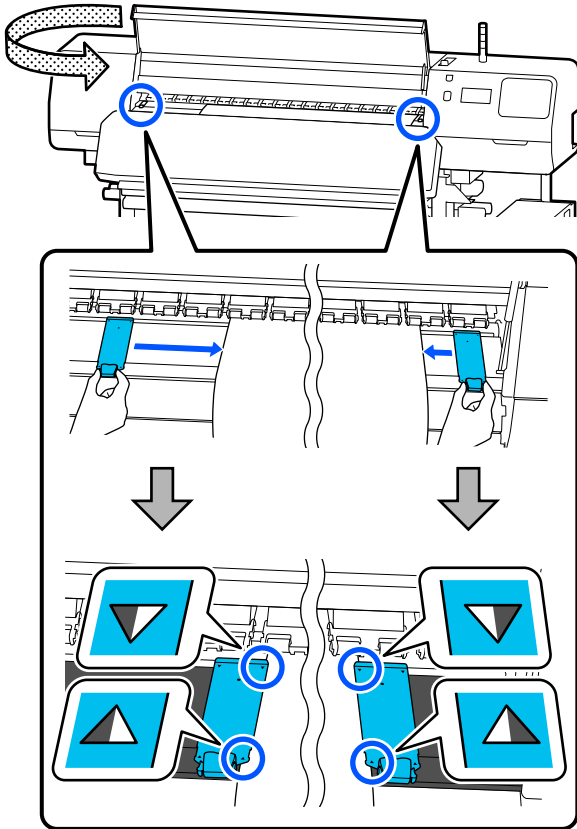

**! Important:**

- Do not use the media edge plates with media that is 0.5 mm (0.02 inches) or more thick. The media edge plates could touch and damage the print head. If you are not using the media edge plates, do not use the thermal sheet either.
- Always position the media edge plates so that the edges of the media are at the centers of the holes. Incorrect positioning causes banding (horizontal banding, tint unevenness, or stripes) during printing.
- Move the media edge plates to the left and right edges of the platen when they are not in use.
- Do not use the media edge plates if the sides of the printed media are smudged.

- 23** When loading media with a width of 54 inches or less, place the thermal sheet supplied on the left-hand side of the left media edge plate. Place it so that the R side of the thermal sheet is on the right.

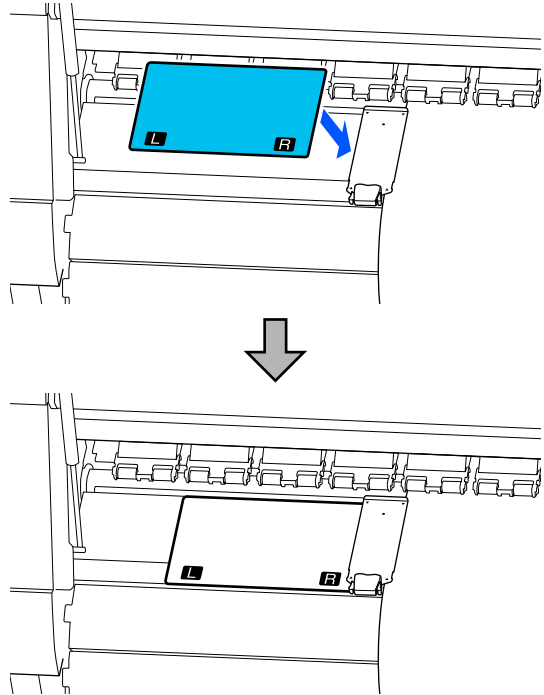

**24**

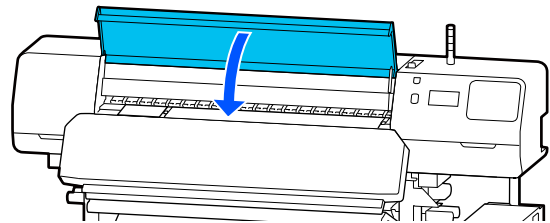

## Settings for Loaded Media

When you have finished loading the media, follow the instructions on the control panel to make settings for the loaded media.

**1. Select the registered media number**

Select the registered media number that contains the media settings corresponding to the loaded media.



## Basic Operations

### 2. Select the roll winding direction

Select the winding direction for the loaded media roll.



### 3. Set the media length

Set the length of the loaded media. The amount of media remaining is managed based on the length entered here.

- 1 When you have finished loading the media, the Media Settings screen is displayed. Press **Media** to access the registered media number where the media setting values for the media you loaded are stored.

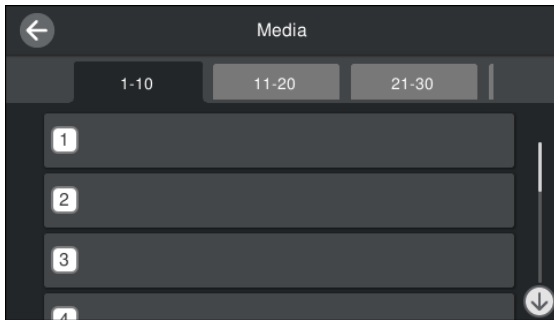

If you select a registered media number for which the **Media Type** is not set for **Media Management**, the screen where you can select the Media Type is displayed. Select the Media Type that matches the media you loaded.

If media settings have not yet been made for new media, select an unassigned number, finish loading the media, and then perform **Media Management**.

- 2 Check the roll specifications.  
On the Media Settings screen, check that the winding direction matches the winding direction for the loaded media.

If the direction is different, press **Roll Winding Direction** to change the setting.

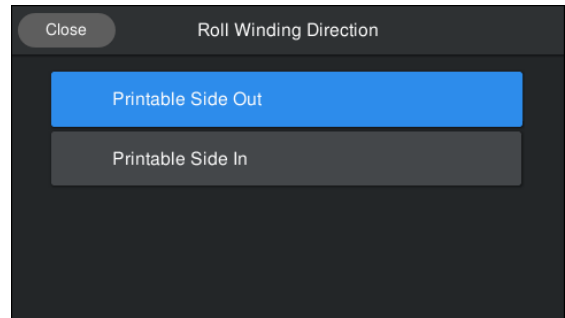

- 3 For media that was replaced and the amount of media remaining has already been printed on, press Remaining Amount Management to set the value.

Press **Paper Remaining - Remaining Amount Management**, and set it to **On**. If this is set to **Off**, Remaining Amount Management is not performed. Press **Remaining Amount** and enter the value for the media remaining that has been printed on the leading edge of the media.

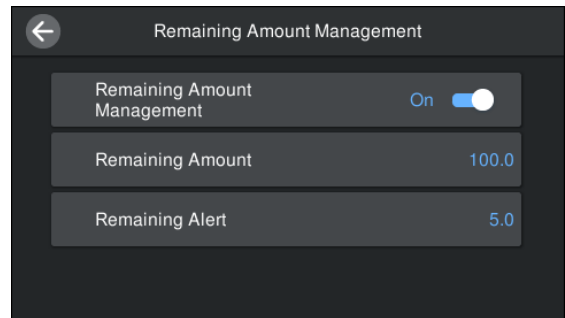

**Note:**  
**Two functions are enabled when Remaining Amount Management is set to On**

*The following two functions give you a rough idea of the amount of media available before printing, making it easier to know when media requires replacement.*

- Showing Amount of Media Remaining**  
*The control panel display shows the approximate amount of media remaining based on the length set for the media and the amount used during printing.*
- Remaining Alert**  
*A warning is displayed when the amount of media remaining reaches a specified level.*

## Basic Operations

- 4** Follow the on-screen instructions. When using the media in the Auto Take-up Reel Unit, press **Feed to Take-up Position**.

See the following for information on loading media in the Auto Take-up Reel Unit.

➤ “Using the Auto Take-up Reel Unit” on page 55

Press **Complete** if you are not using the Auto Take-up Reel Unit.

After a while, the message **Ready to print.** is displayed on the screen and you can start printing. Transmit the data to be printed from the computer.

## Using the Auto Take-up Reel Unit

The Auto Take-up Reel Unit automatically takes up media as it is printed, improving the efficiency of unmanned operation.

The Auto Take-up Reel Unit for this printer can take up media in either of the following directions.

Printed side out



Printed side in



Taking-up with printed side out places the printed surface on the outside of the roll.

Taking-up with printed side in places the printed surface on the inside of the roll.

You can check the procedure in a video on YouTube.

[Epson Video Manuals](#)

### **Caution:**

- ❑ Follow the instructions in the manual when loading media or roll cores or removing media from the take-up roll. Dropping media, roll cores, or take-up rolls could result in injury.
- ❑ Be sure that your hands or hair do not get caught in the Media Feeding Unit or Auto Take-up Reel Unit while it is operating. Failure to observe this precaution could result in injury.

## Attaching the Roll Core

**Prepare a roll core that is longer than the width of the media to be wound.**

This allows the media to be taken up without protruding from the core.

- 1** Feed the media to the sticking position.

### **When performing operations after loading the media**

Follow the on-screen instructions. Press **Feed to Take-up Position** to feed the media to the sticking position.

### **When performing something other than the above**

Press and hold the  button on the control panel to feed the media to the media holder position.

### **Important:**

*Do not pull the media by hand. If the media is pulled by hand, the media may twist during take-up.*

**Basic Operations**

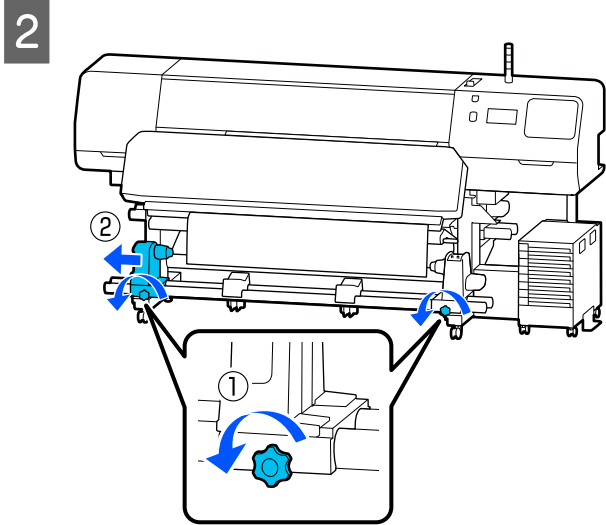

**3** Align the media holder with the right edge of the media, and tighten the screw.

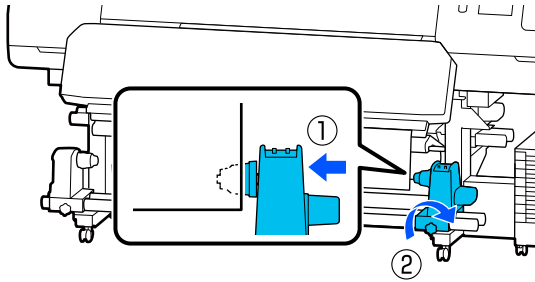

**4** Insert the roll core onto the right media holder.

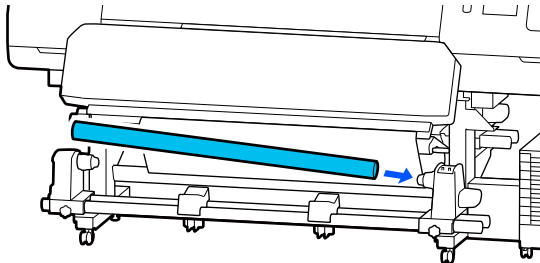

**5** Push the holder until part A shown in the illustration below is fully inserted, and tighten the screw.

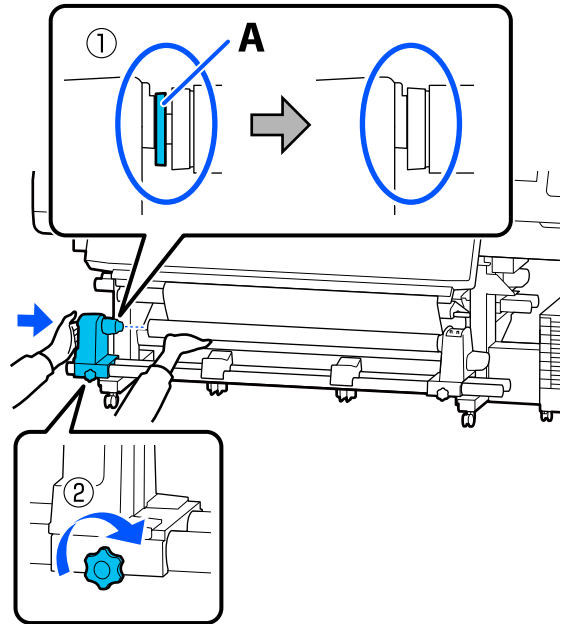

**Important:**

*Stop when part A is no longer visible. The take-up reel unit may not function as expected if the holder is inserted too far.*



Basic Operations

- 6 Leave a 10 to 20 cm (3.94 to 7.87 inches) wide section in the center of the media, and cut at least 25 cm (9.84 inches) in height from the left and right corners of the media.

Cutting the media prevents feeding problems, such as the left and right corners of media being folded and caught at the start of take-up.

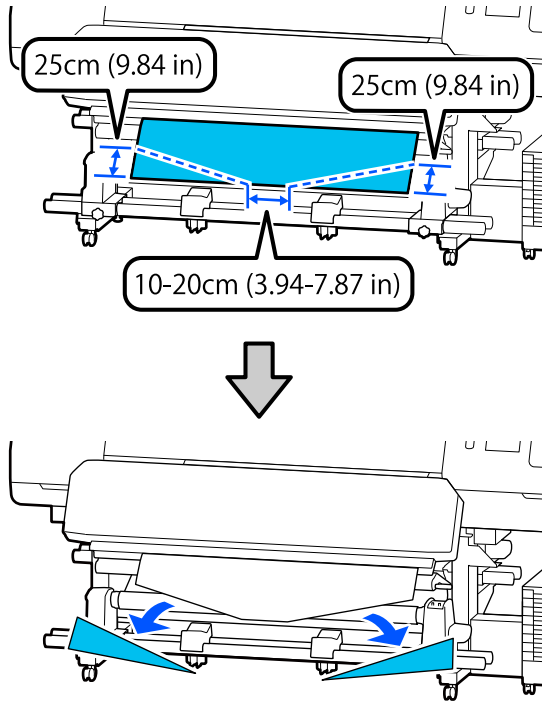

For the subsequent steps, see the following depending on how the media is rolled.

For information on taking-up with printed side out, see [“Take-up with the Printed Side Facing Out” on page 57.](#)

For information on taking-up with printed side in, see [“Take-up with the Printed Side Facing In” on page 59.](#)

## Take-up with the Printed Side Facing Out

- 1 While pulling the center section of the media straight down, affix the media to the take up roll core with commercially available adhesive tape.

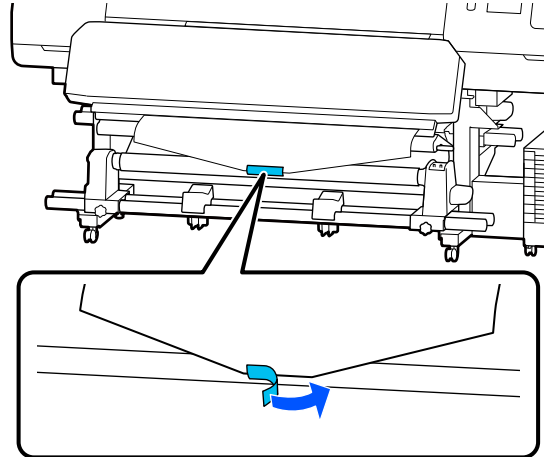

**Important:**

Attach the media to the take up roll core with the media in a taut state. If media is attached in a loose state, the media may move around during take-up.

- 2 Press the button on the control panel to feed enough media for a single wrap around the roll core.

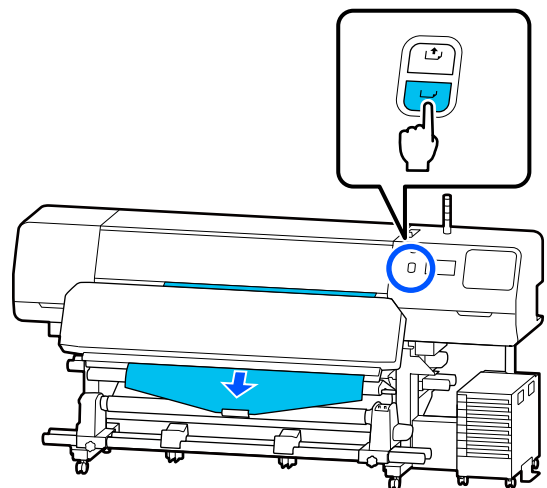

### Basic Operations

- 3** Flip the Auto switch to Off, and hold down the Manual switch to  to wrap the media once around the roll core.

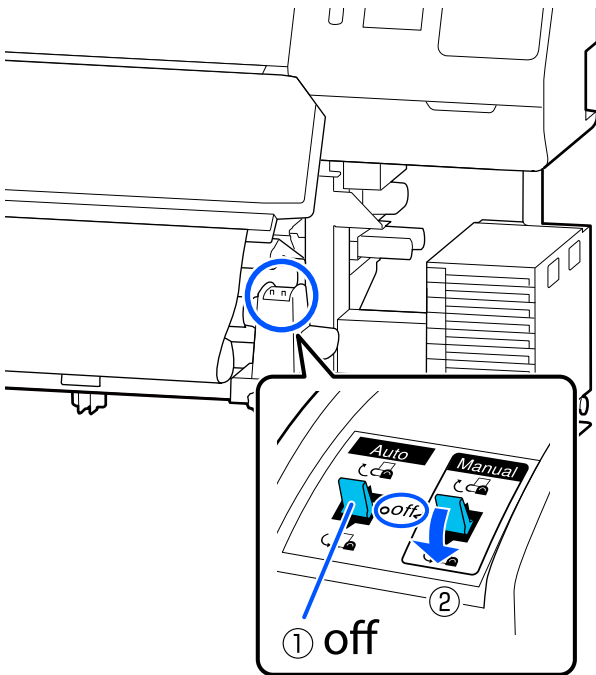

- 4** Flip the Auto switch to .

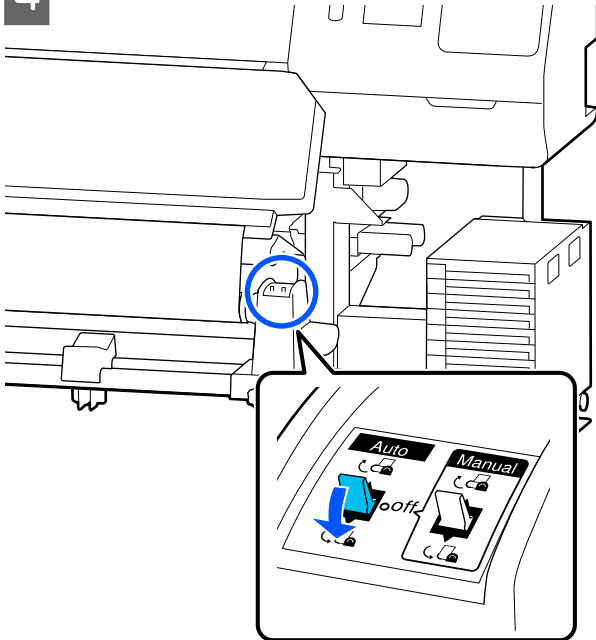

- 5** Lower the tension bar until it slightly touches the media.

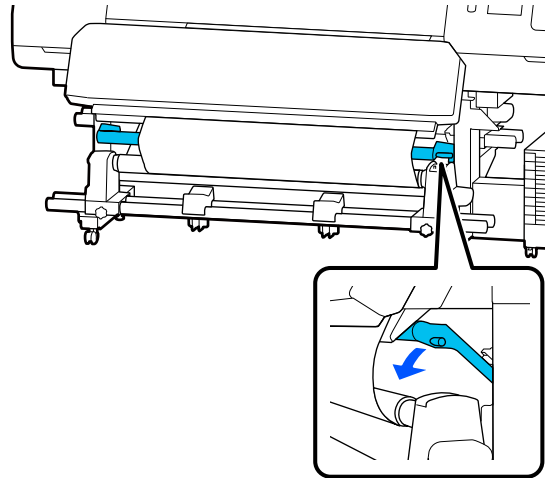

- 6** Confirm that the media is attached without looseness.

If the tension on the left and right of the media is different as shown in the illustration below, the media will not be taken up correctly. When one side is loose, restart the procedure from Step 1.

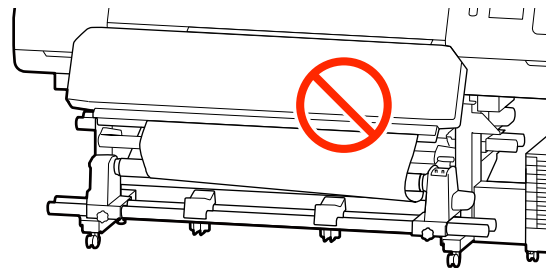

**Note:**

You can confirm differences in tension by lightly tapping both edges of the media as shown in the illustration below.

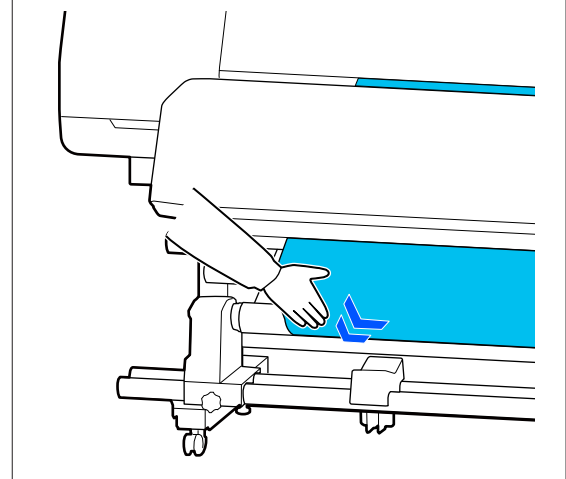

### Basic Operations

- 7** Continue holding down the  button until the media has wrapped around once or twice.

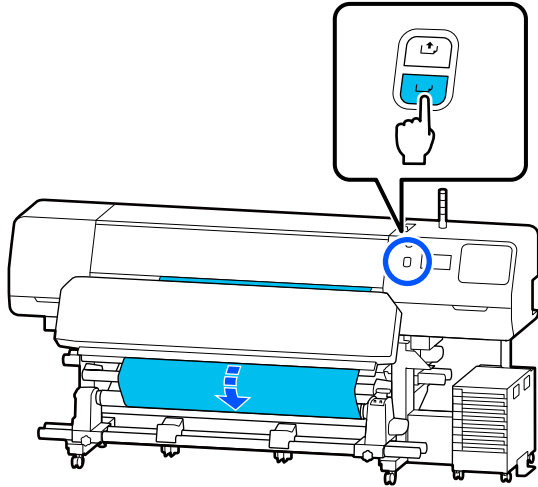

- 8** Press **Complete** on the screen.  
When you switch to the home screen, **Ready to print.** is displayed on the screen and you can start printing. Transmit the data to be printed from the computer.

### Take-up with the Printed Side Facing In

- 1** While pulling the center of the media straight down, wrap it around the roll core from back to front, and affix it using commercially available adhesive tape.

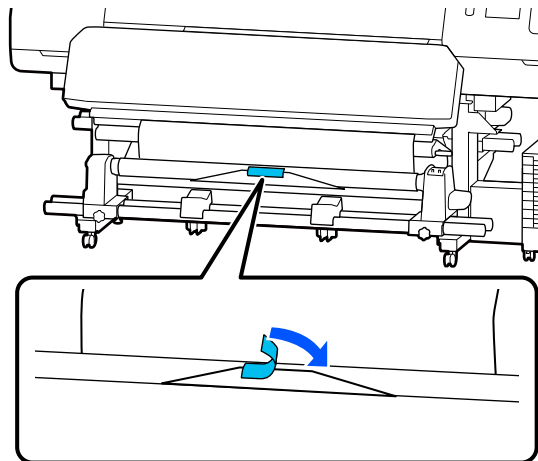

**!** **Important:**

Attach the media to the take up roll core with the media in a taut state. If media is attached in a loose state, the media may move around during take-up.

- 2** Press the  button on the control panel to feed enough media for a single wrap around the roll core.

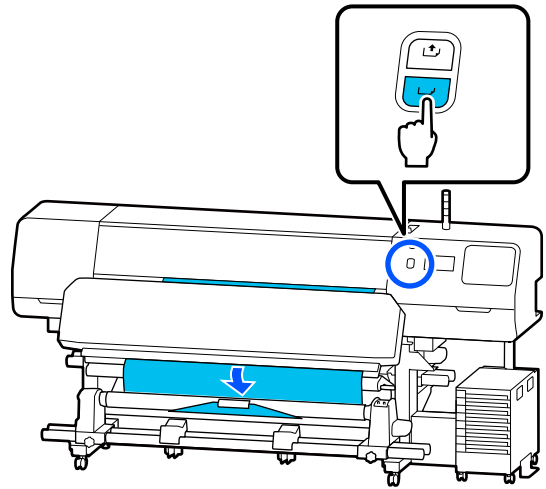

- 3** Flip the Auto switch to Off, and hold down the Manual switch to  to wrap the media once around the roll core.

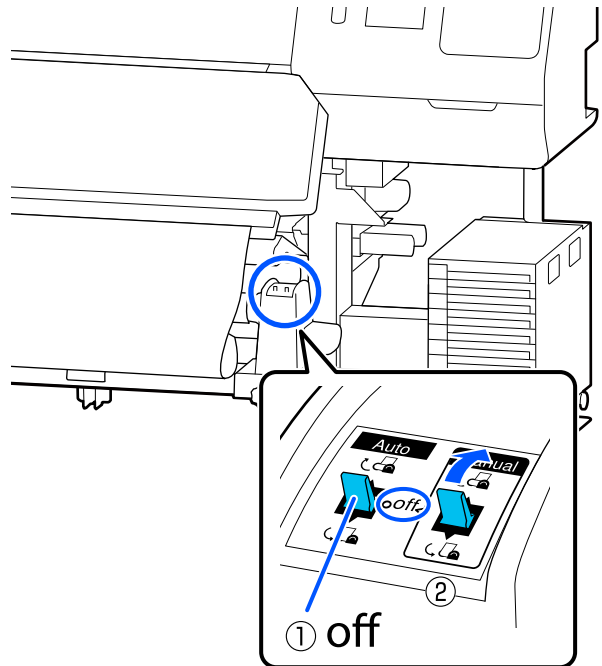

### Basic Operations

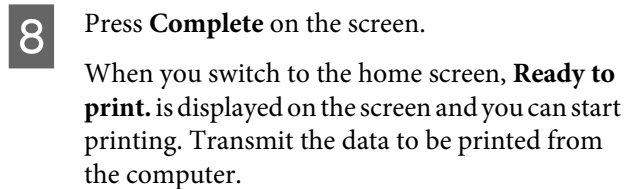
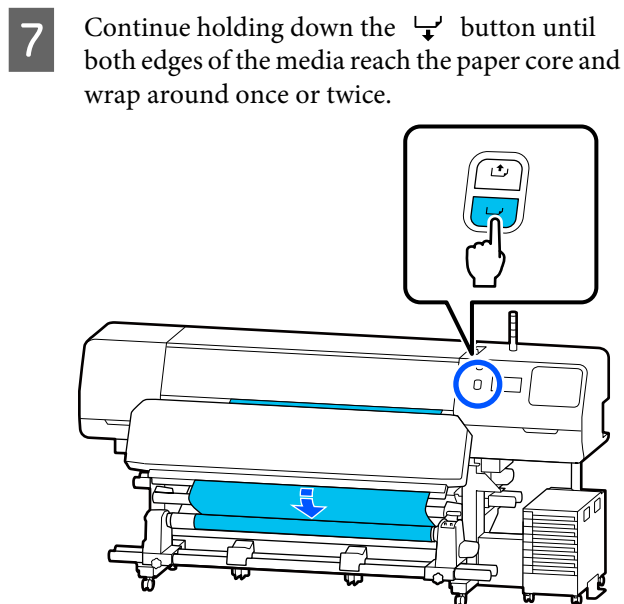
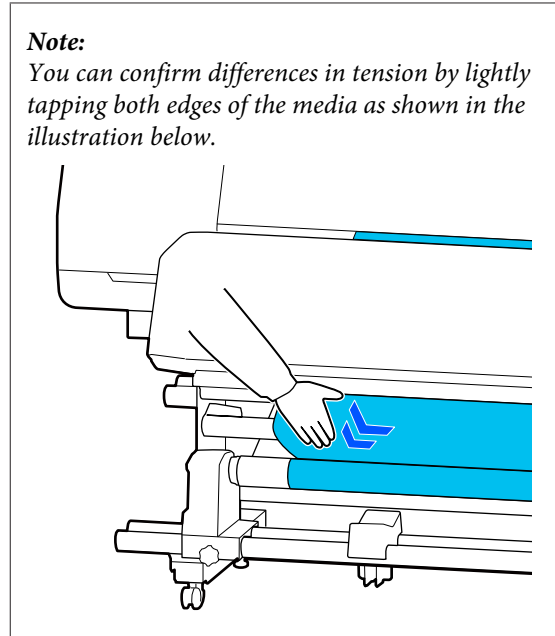
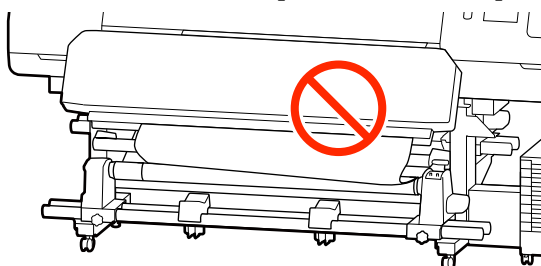
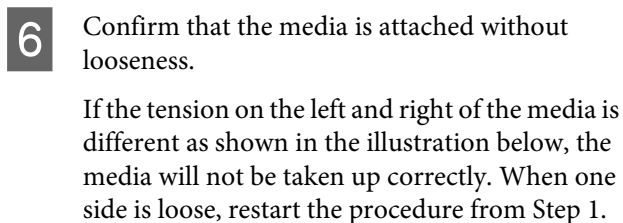
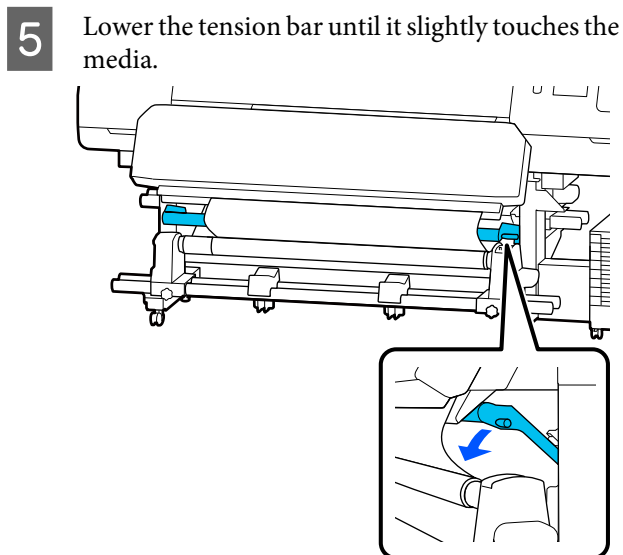
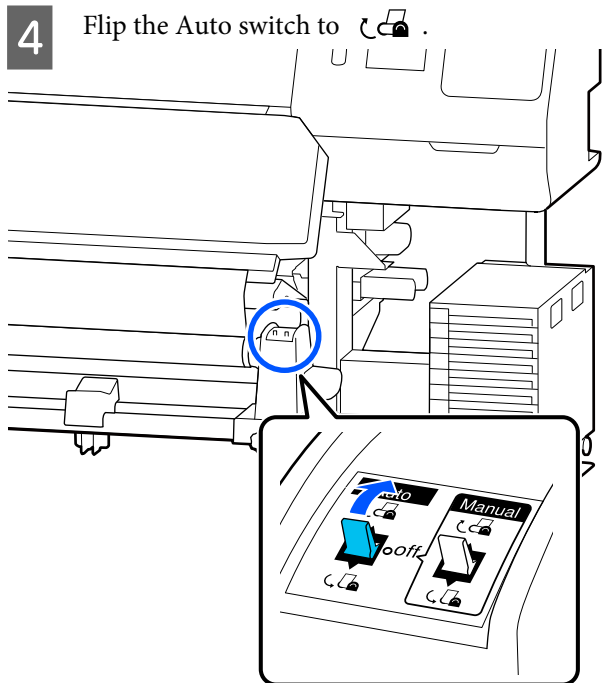

## Optimizing Media Settings (Automatic Adjustment)

You should optimize the media settings in the following situations. To optimize the media settings, perform **Automatic Adjustment** from **Print Adjustments**.

### When registering media settings in the EMX file to the printer

When the media settings of an EMX file downloaded from Epson Edge Print/Epson Edge Dashboard are registered to the printer, the media settings are optimized to correct individual differences in your media and printer so that you can perform optimal printing using your media and printer combination.

### When changing Advanced Settings after saving media settings

## Precautions when performing Print Adjustments

**Adjustments are made according to the media loaded in the printer.**

- ❑ Using the actual printing conditions, correctly load the media that needs to be adjusted in the printer. If you are attaching the Auto Take-up Reel Unit to print, place the media on the Auto Take-up Reel Unit during Print Adjustments.
- ❑ When registering the media settings to the printer, make sure you select the name set in **Media Management** from the Settings menu in **Select Media**.

### Make sure nozzles are not clogged before adjusting.

If nozzles are clogged, adjustments will not be performed correctly.

Print to visually inspect the check pattern (Standard), and then perform Print Head Cleaning if necessary.

 [“Print Head Nozzle Check” on page 95](#)

**Make sure that the media remaining is approximately 1.6 m (63 in) or more.**

If there is less than approximately 1.6 m (63 inches) of media remaining, a media end error may occur during the curing process and so on. If this error occurs, you may not be able to make adjustments, so always check the amount of media remaining before making adjustments.

## Automatic Adjustment Procedure



Automatic Adjustment performs Media Feed Adjustment and Print Head Alignment automatically while printing the pattern.

The approximate length of the media required to print the test pattern is given below.

Approximately 300 mm (11.8 inches)

You may not be able to perform Automatic Adjustment depending on the media you are using. If an error occurs, or if you notice banding or graininess in the print results even after performing Automatic Adjustment, perform **Manual Adjustment** from the Print Adjustments menu.

 [“If you cannot perform Automatic Adjustment” on page 62](#)

- 1** Check that the printer is ready, and load the media according to the actual usage conditions.  
When using the Auto Take-up Reel Unit, attach the media to the roll core.  
 [“Loading media” on page 47](#)  
 [“Using the Auto Take-up Reel Unit” on page 55](#)
- 2** Press  (menu), and then press **Media Settings - Print Adjustments - Automatic Adjustment**.
- 3** Press **Start**.  
Auto adjust starts, and the adjustment pattern is printed.  
Wait until adjustment is complete.

## Basic Operations

### If you cannot perform Automatic Adjustment

Perform **Media Feed Adjustment** and **Print Head Alignment** separately. In both cases, visually inspect the printed pattern and enter the measurements to perform adjustments.

Before making adjustments, be sure to read the following:

[“Precautions when performing Print Adjustments” on page 61](#)

When you select **Media Feed Adjustment** and **Print Head Alignment** in **Manual Adjustment** from the Print Adjustments menu to start making adjustments, Print Head Alignment continues when Media Feed Adjustment is complete.

If you only select one of these and start the adjustments, only the selected adjustment is made.

### Media Feed Adjustment

This menu is also used when banding (horizontal banding, tint unevenness, or stripes) is detected in printing results.

You can select from **Manual (Standard)** or **Manual (Measurement)** to perform adjustments.

#### Manual (Standard)

Usually, this is selected.

[“Setting procedure for Manual \(Standard\)” on page 62](#)

#### Manual (Measurement)

This is useful for making accurate print adjustments when printing on uneven media such as canvas or media that bleeds-through easily, such as cloth.

[“Setting procedure for Manual \(Measurement\)” on page 63](#)

The approximate length of the media required to print the test pattern is given below.

When performing **Manual (Standard)**: Approx. 100 mm (3.94 inches)

When performing **Manual (Measurement)**: Approx. 770 mm (27.55 inches)

#### Setting procedure for Manual (Standard)

- 1 Check that the printer is ready, and load the media according to the actual usage conditions.  
When using the Auto Take-up Reel Unit, attach the media to the roll core.  
[“Loading media” on page 47](#)  
[“Using the Auto Take-up Reel Unit” on page 55](#)
- 2 Press  (menu), and then press **Media Settings - Print Adjustments - Manual Adjustment**.  
Press  on the left of **Media Feed Adjustment**. The icon changes to  and the adjustment type selection screen is displayed.
- 3 Press **Manual (Standard)**.
- 4 Press **OK**, and then press **Start**.  
An adjustment pattern is printed. Wait until printing is complete.
- 5 Check the printed adjustment pattern.  
Two groups of adjustment patterns, A and B, are printed. Select the pattern with the least amount of overlapping or gaps for each group. Select "0.0" in the cases shown below.

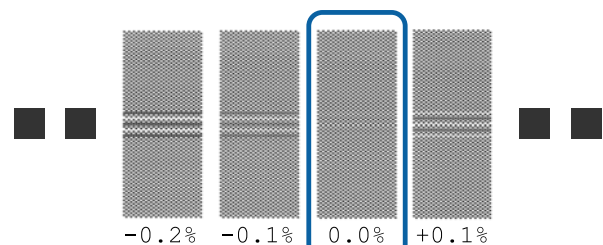

## Basic Operations

If there are patterns with the same overlapping or gaps, enter the middle value in step 6. Enter "-0.05%" in the cases shown below.

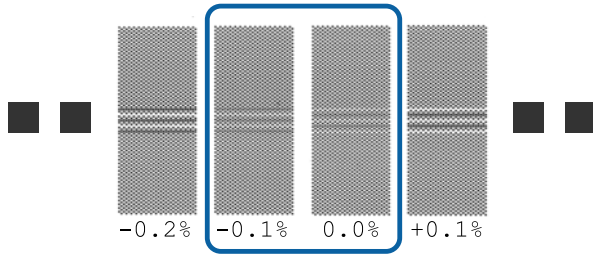

If all of the adjustment patterns contain overlapping or gaps, select the pattern with the least overlaps or gaps.

In this situation, perform step 6 and then press **Yes** in step 7.

**6** The screen for entering confirmation results for the adjustment pattern is displayed.

Set the values printed under the patterns selected in A and B, and then press **OK**.

**7** Select whether or not to make the same adjustments again.

Select **Yes** if there are rows of patterns with the same overlap or misalignments in step 5. You can make adjustments again using the adjustment pattern that reflects the measurements you entered.

Press **No** to finish **Media Feed Adjustment**. If you also select **Print Head Alignment**, the **Print Head Alignment** adjustment pattern print confirmation screen is displayed.

If you do not select **Print Head Alignment**, **Manual Adjustment** closes.

### Setting procedure for Manual (Measurement)

**1** Check that the printer is ready, and load the media according to the actual usage conditions.

When using the Auto Take-up Reel Unit, attach the media to the roll core.

"Loading media" on page 47

"Using the Auto Take-up Reel Unit" on page 55

**2** Press (menu), and then press **Media Settings - Print Adjustments - Manual Adjustment**.

Press on the left of **Media Feed Adjustment**. The icon changes to and the adjustment type selection screen is displayed.

**3** Press **Manual (Measurement)**.

**4** Press **OK**, and then press **Start**.

An adjustment pattern is printed. Wait until printing is complete.

When printing is complete, curing is performed and the end of the print is sent to the cutting position.

**5** Check the printed adjustment pattern.

Cut after the adjustment pattern, spread it out on a flat surface, and then measure it using a scale. Use a scale that can measure in increments of at least 0.5 mm.

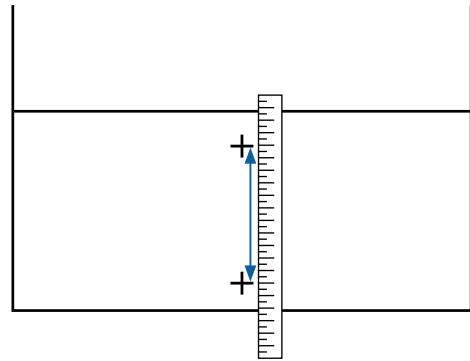

**6** The screen for entering confirmation results for the adjustment pattern is displayed.

Set the value established in step 5, and then press **OK**. If you also select **Print Head Alignment**, the **Print Head Alignment** adjustment pattern print confirmation screen is displayed. When using the Auto Take-up Reel Unit under actual usage conditions, load the media in the Auto Take-up Reel Unit before printing the adjustment pattern.

If you do not select **Print Head Alignment**, **Manual Adjustment** closes.

## Print Head Alignment

This menu is also used when graininess is detected in printing results.

## Basic Operations

- 1 Check that the printer is ready, and load the media according to the actual usage conditions.

When using the Auto Take-up Reel Unit, attach the media to the roll core.

[☞ “Loading media” on page 47](#)

[☞ “Using the Auto Take-up Reel Unit” on page 55](#)

- 2 Press  (menu), and then press **Media Settings - Print Adjustments - Manual Adjustment**.

Press  on the left of **Print Head Alignment**. The icon changes to 

- 3 Press **OK**, and then press **Start**.

An adjustment pattern is printed. Wait until printing is complete.



- 4 Check the printed adjustment pattern.

Two blocks, A and B are printed. Select the finest lined pattern (all lines overlap) for both. Select “-1” in the cases shown below.

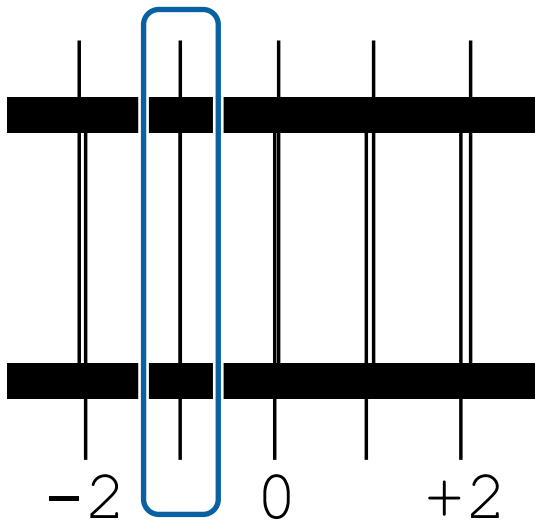
If there are patterns with the same overlapping or gaps, select the pattern that looks the thinnest, perform step 6, and then press **Yes** in step 7.



- 5 The screen for entering confirmation results for the adjustment pattern is displayed.

Using  / , enter the pattern number recorded in step 4, and then press **OK**.

- 6 Set the number per check pattern, and then press **OK**.

- 7 Select whether or not to make the same adjustments again.

Select **Yes** if there are rows of patterns with the same overlap or misalignments in step 5. You can make adjustments again using the adjustment pattern that reflects the measurements you entered.

Press **No** to finish **Print Head Alignment**.

## Replacing the Media

This section explains how to replace media with another media while there is still media remaining, and how to replace media with new media when the media ends.

See the following according to your needs.

[☞ “Replacing Expended Media” on page 64](#)

[☞ “Replacing Media that is not Expended ” on page 65](#)

### Replacing Expended Media

If the media runs out during printing, a **No media error** is displayed on the control panel screen.

- 1 Check the content of the message.  
**No media is loaded. is displayed**

Go to step 3.

**Move to the back, and then use scissors to cut off the roll media. is displayed**

Use commercially available scissors to cut the media just above the roll core at the back of the printer.

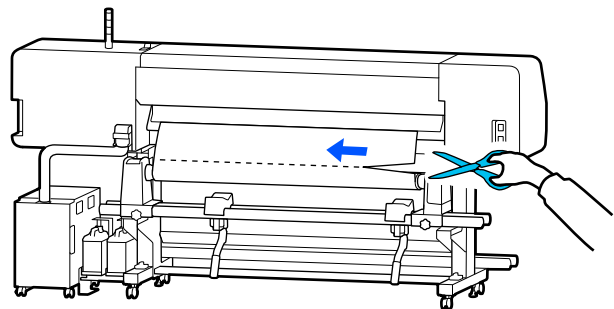



## Basic Operations

- 2 Press **OK** on the screen, to start curing the printed section.  
When curing is complete, the message **No media is loaded.** is displayed.
- 3 To continue printing, remove the media from the Auto Take-up Reel Unit, and then load new media.  
[🔗 “Removing the Take-up Roll” on page 66](#)  
[🔗 “Loading media” on page 47](#)
- 4 When new media is loaded and the printer is ready to print, the rest of the job is printed.

### Replacing Media that is not Expended

Follow the steps below when replacing media that is still being used.

**1. Cut the media.**



**2. Remove the media.**

[🔗 “Removing the Take-up Roll” on page 66](#)

### Printing the amount of media remaining

If the following two settings are set to **On** in advance, when an operation to feed the media to the cutting position is performed, the remaining length of the media and the printer's information is printed and then the media end is fed to the cutting position. You can print the length of the unprinted media on the media that you will remove, and then the next time you load this media, you can enter the printed length in the Remaining Amount Management setting for accurate management of the amount of media remaining.

- Remaining Amount Management - On
- Paper Remaining Information - On

The following information is available for the printer. When **Remaining Amount Management** is set to **Off**, only the following information is printed.

- Model name: Model of the printer
- Serial number: Serial number of the printer
- Date and time: Date and time of printing
- Bank number: Registered media number selected when printing
- Media type: Media Type of the registered media selected when printing
- Media width: Automatically detected value of media width

### Cutting media

- 1 Confirm that the printer is ready to print.
- 2 Check that the end of the print is at the cutting position (cutter groove).

Depending on the settings for the currently selected registered media, the end of the print may be one of the following:

#### When the end of the print has been fed to the cutting position

Go to step 3.

#### When the end of the print has not been fed to the cutting position

Press  (feed media to cutting position) on the control panel screen to feed the end of the print to the cutting position.

Basic Operations

- 3** When using the Auto Take-up Reel Unit, raise the tension bar.

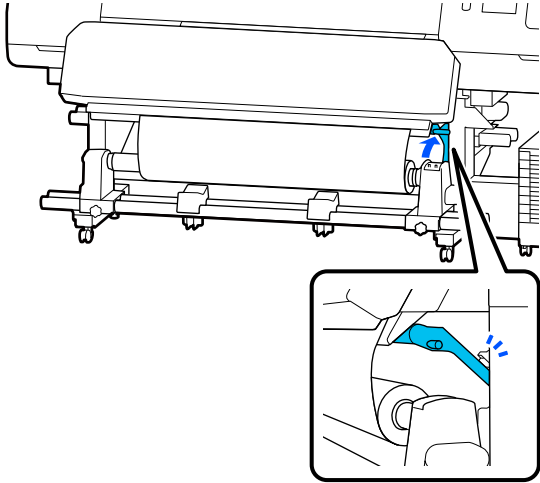

- 4** Raise the cutter, and then move it so that the cutter blade fits the cutter groove properly.

**⚠ Caution:**

- ❑ The curing heater may be hot; observe all necessary precautions. Failure to observe the necessary precautions could result in burns.
- ❑ Do not put your hand inside the curing heater. Failure to observe the necessary precautions could result in burns.
- ❑ When cutting media, be careful not to cut your fingers or hands with the cutter or other blades.

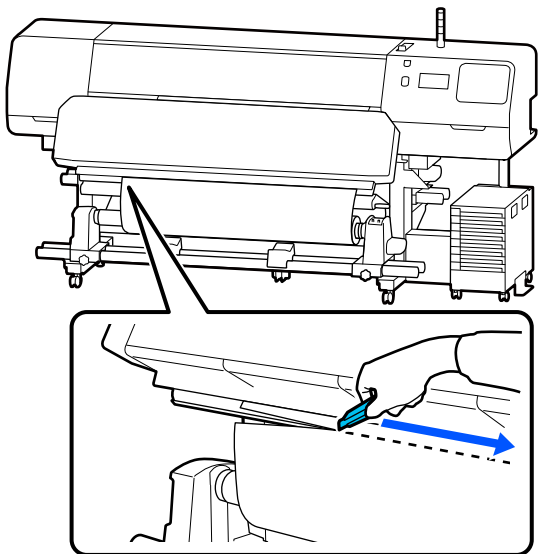

## Removing the Take-up Roll

**⚠ Caution:**

- ❑ If the media weighs over 20 kg (44 lbs.), it should not be carried by one person. When loading or removing the media, use at least two people.
- ❑ Follow the instructions in the manual when loading media or roll cores or removing the take-up roll. Dropping media, roll cores, or take-up rolls could result in injury.

- 1** Flip the Auto switch to Off. Take up the cut media completely by operating the Manual switch according to how the media is rolled.

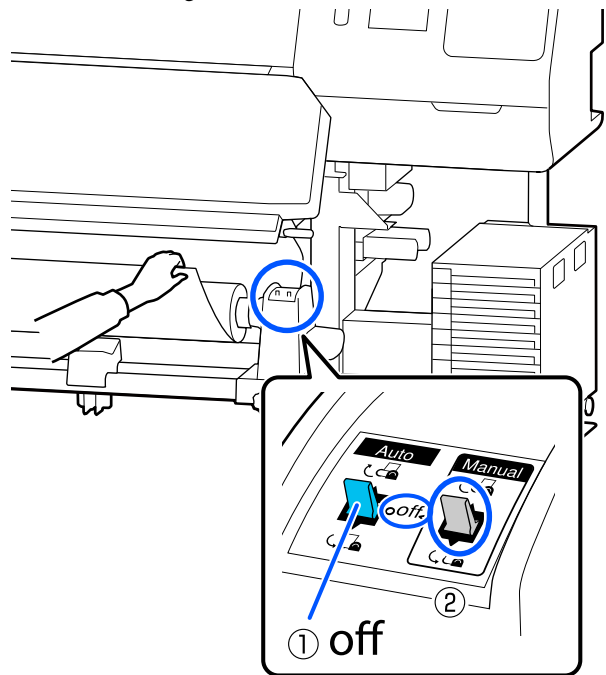

- 2** To prevent the media from sliding off the roll, support the roll at its left end.

Basic Operations

- 3** Loosen the left media holder fixing screw and remove the media holder from the roll.

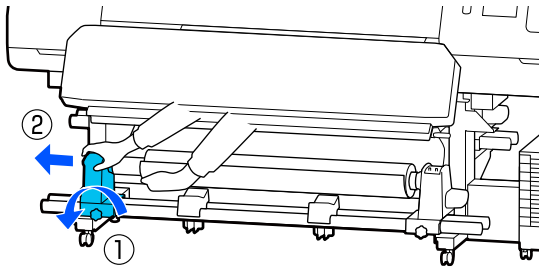

- 4** Lower the roll onto the media support.

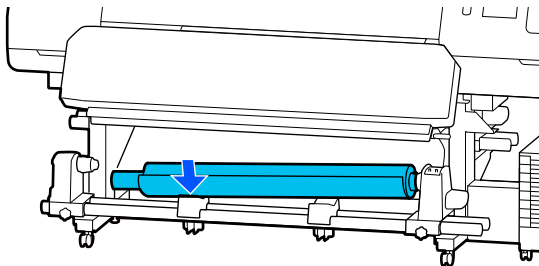

- 5** To prevent the media from sliding off the roll, support the roll at its right end.

- 6** Loosen the right media holder fixing screw and remove the media holder from the roll.

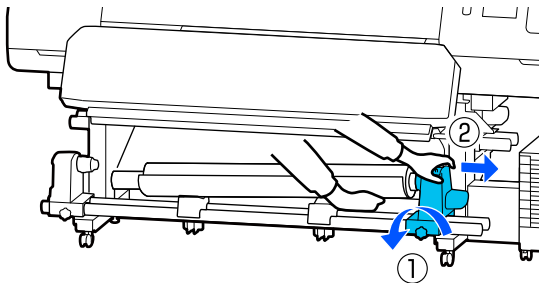

- 7** Lower the roll onto the media support.

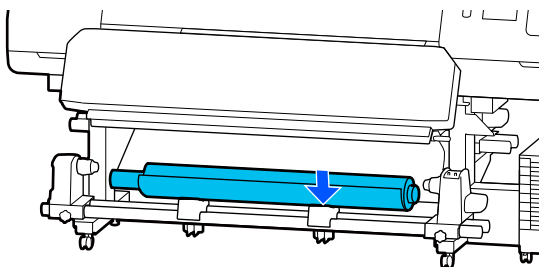

- 8** To remove media from the rear media feeding unit, reverse the steps you followed to load it.



**Important:**

After removing the media, move the media loading lever to the front.

## Before Printing

To maintain print quality, perform the following inspection before starting work each day.

### Checking the amount of ink remaining: (for the SC-R5000 Series)

If ink is expended while printing, printing can be resumed once the affected ink supply unit has been replaced. However, if you replace it while printing, colors may look different depending on how the ink dries. If you know that the print job will be a large one, we recommend that you use new ink supply units to replace those that are running low before you start. You can still use the removed ink supply unit in the future until the ink supply unit is expended.

Ink level is shown by an icon. [☞ “Understanding the Display” on page 17](#)

Replacing ink supply units [☞ “Replacement procedure” on page 88](#)

### Checking the amount of ink remaining: (for the SC-R5000L Series)

When ink is expended, the ink supply automatically switches to another ink supply unit of the same color. Since printing continues as it is, replace the ink supply unit for which ink is expended while there is still enough ink remaining in the ink supply unit that is currently operating. You cannot print if the amount of ink remaining in both ink supply units of the same color are expended.

Press the ink status icon area on the home screen to check how much ink is remaining in the operational and non-operational ink supply units.

Replacing ink supply units [☞ “Replacement procedure” on page 88](#)

### Checking the nozzle check pattern

You can check the status of the nozzles by printing a nozzle check pattern.

If you think that there is banding or unevenness in the printed nozzle check pattern, perform Print Head Cleaning.

Print a Check Pattern [☞ “How to Print a Nozzle Check Pattern” on page 95](#)

## Basic Operations

Print Head Cleaning  [“Print Head Cleaning” on page 96](#)

# Changing settings during printing

You can change the following settings during printing.

- Correct the media feed amount
- Set the temperature for the curing heater/platen heater/pre-heater
- Drying Time  
You can only change the setting when **Drying Action** is set to **Follow Drying Time Setting**.
- Platen Gap value

The following example explains how to change the temperature setting for each heater, and how to correct the media feed amount when banding occurs in the printouts.



## Changing the temperature for each heater

- 1** Press  in the **Settings** area of the startup adjustment screen.

The area for changing the temperature for each heater is displayed.

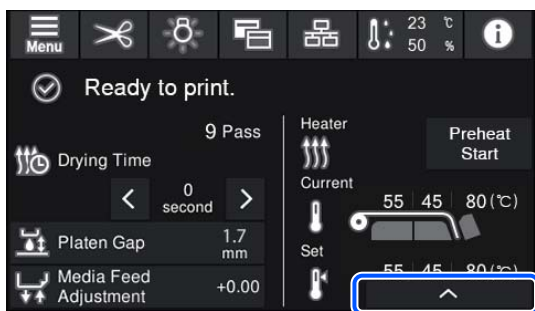
You can also change this setting by pressing the heater temperature area on the home screen.



- 2** Choose a value.  
Press  /  below the image of the heater for which you want to change the temperature.

- 3** When you press , the area for changing the set temperature closes, and the settings are updated for the currently selected registered media.

The value of the temperature for the curing heater is retained for each Pass Mode of the selected registered media number. The value for the currently selected Pass Mode is updated with the value changed here.

**Note:**

*The time needed for the heaters to reach the specified temperatures varies with the ambient temperature.*





## Correcting Banding

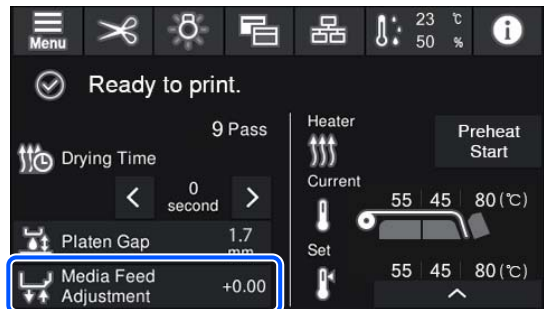

When you want to correct banding during printing, correct the media feed amount.



- 1** During printing, press the following area on the startup adjustment screen.







If the startup adjustment screen is not displayed, press  (switch screens) on the home screen.

- 2** Press  /  on the screen, or press the  /  buttons on the control panel to change the value.

If the feed amount is too small, black bands (dark stripes) appear; press the  (or  button) to adjust the feed amount upwards.

In contrast, if the feed amount is too large, white bands (pale stripes) appear; press the  (or  button) to adjust the feed amount downwards.

## Basic Operations

- 3** Check the printing result. If you are not satisfied with the results, use the /, or the / buttons on the control panel to change the value.

The setting for the currently selected registered media number is updated.

- 4** Press  to return to the home screen.

**Note:**

*The results of changing the settings are un-done if you perform any of the following operations.*

- Restart **Media Feed Adjustment**.*
- Execute **Clear All Data and Settings**.*

When you have finished the target printing, we recommend performing **Print Adjustments** from the settings menu.

 [“Optimizing Media Settings \(Automatic Adjustment\)” on page 61](#)

**Basic Operations**

# Printable area

**The left and right edges of media recognized by the printer varies as shown below according to the Width Detection settings.**

**Width Detection On** : The printer automatically detects the left and right edges of the loaded media.

When media edge plates are attached, the area within 5 mm (0.2 inches) of the left and right edges of the media is recognized as the media edge.

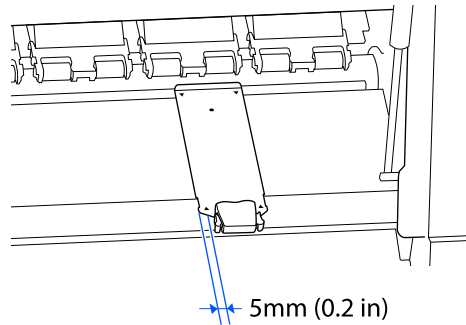

The edges of the media are not detected correctly if the media edge plates are not attached correctly.

 [“Loading media” on page 47](#)

**Width Detection Off** : The center of the black rectangle on the label below is the standard position for the right edge of the media. The left edge of the media is the value set (300 to 1625.6 mm [11.81 to 64.00 in]) in **Width Detection - Off** in the settings menu, regardless of the width of the media that is loaded.

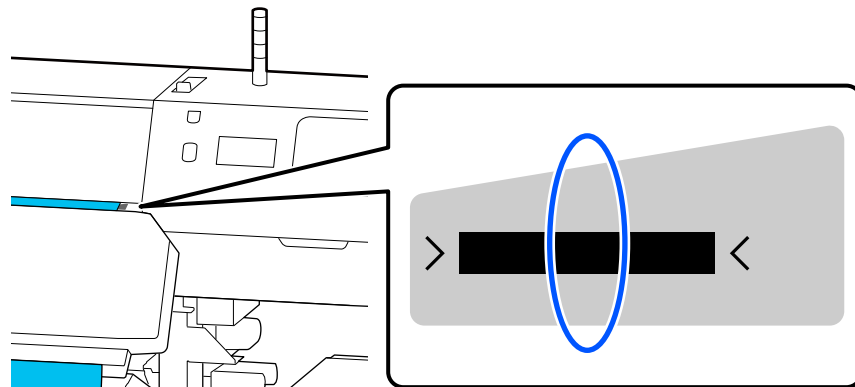

## Basic Operations

The gray area in the illustration below shows the printable area. The arrow indicates the feed direction.

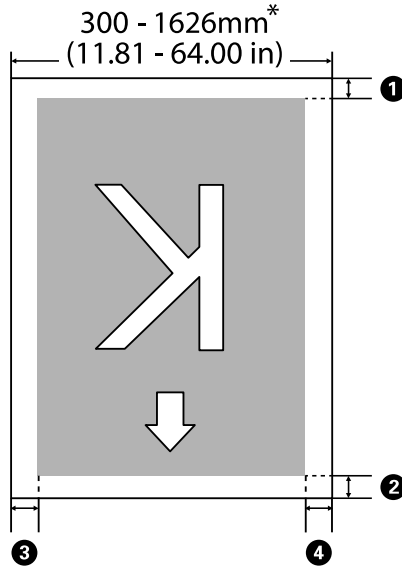

\* When the Width Detection setting is set to **Off**, the value set at that time (300 to 1625.6 mm [11.81 to 64.00 in]) is used.

① to ④ indicates the margins on all four sides. See the following for more details.

Margin Position	Explanation	Available Setting Range
① Rear* <sup>1</sup>	Half of the value set in <b>Margin Between Pages</b> is added as a margin. This can also be set in the RIP.	0 to 499.5 mm (0 to 19.67 inches)
② Leading edge* <sup>1</sup>		
③ Right edge* <sup>2, 3</sup>	The total of the values set for Print Start Position and Side (Right) in the printer's Printer Settings menu. The default setting for Print Start Position is 0 mm and Side (Right) is 5 mm.	3 to 1000 mm (0.12 to 39.37 inches)
④ Left edge* <sup>2, 3</sup>	The value set for Side (Left) in the printer's Printer Settings menu. The default setting is 5 mm.	3 to 25 mm (0.12 to 0.98 inches)

\*1 The set margin and the actual print results may differ depending on the RIP being used. Contact the RIP manufacturer for more information.

\*2 This may be available in the RIP depending on the RIP software being used. Contact the RIP manufacturer for more information.

\*3 Note the following points when setting margins.

- Leave margins of 5 mm (0.2 inches) or more when using media edge plates. Narrower margins could result in the printer printing on the media edge plates.
- If the total of the print data width and the left and right margins exceeds the printable area, a portion of the data will not be printed.

## Basic Operations

**Note:**

If the following points are not observed when **Width Detection** is set to **Off**, printing may occur outside the left and right edges of the media. Ink used outside the edges of the media will stain the inside of the printer.

- ❑ Ensure that the print data width does not exceed the loaded media width.
- ❑ When media is loaded to the left of the right side reference position, align the **Print Start Position** setting with the position where the media set.  
 ["General Settings menu" on page 106](#)



# Maintenance

## When to Perform Various Maintenance Operations

### Components Requiring Regular Cleaning and Cleaning Timing

If you continue to use the printer without cleaning, it could cause clogged nozzles or ink drops to occur.

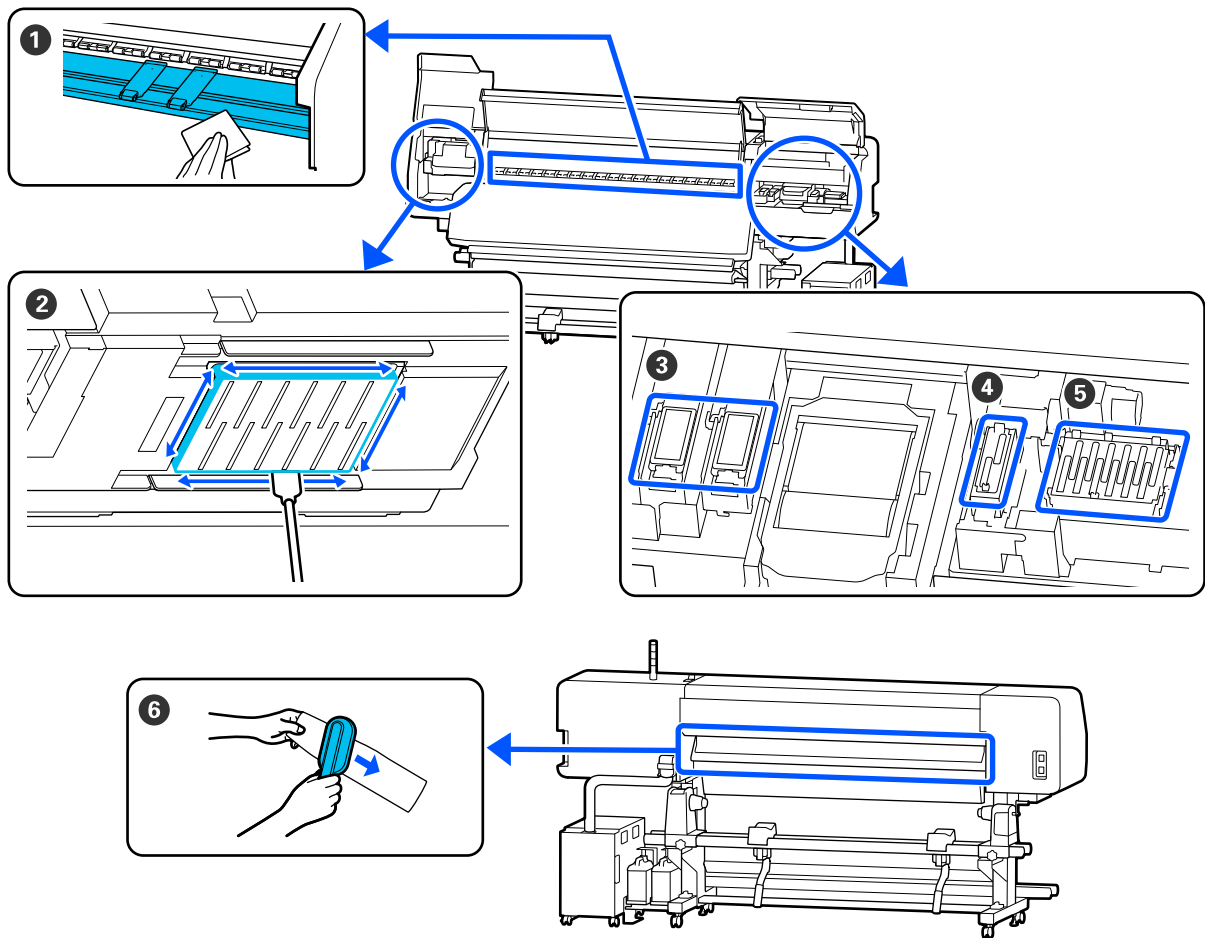

When to perform	Component to be cleaned
When starting work every day	<b>1</b> Platen heater/media edge plates 📖 "Daily Cleaning" on page 77

### Maintenance

When to perform	Component to be cleaned
When a cleaning message is displayed on the control panel screen (Messages are displayed regularly)	<p>② Around the print head  <a href="#">“Cleaning Around the Print Head” on page 79</a></p> <p>③ Flushing pad  <a href="#">“Cleaning Around the Flushing Pad” on page 84</a></p> <p>④ Suction Cap  <a href="#">“Cleaning the Suction Cap” on page 83</a></p> <p>⑤ Anti-drying caps  <a href="#">“Cleaning the anti-drying caps” on page 80</a></p> <p>You can check the procedure in a video on YouTube.  <a href="#">Epson Video Manuals</a></p>
When a cleaning message is displayed on the control panel screen (Messages are displayed regularly)	<p>⑥ Media cleaner  <a href="#">“Cleaning the Media Cleaner” on page 85</a></p>

**! Important:**

The printer contains precision instruments. If any lint or dust adheres to the nozzles on the print head, print quality will decline.

Perform regular cleaning more frequently depending on the environment and media being used.

### Locations of Consumables and Replacement Timing

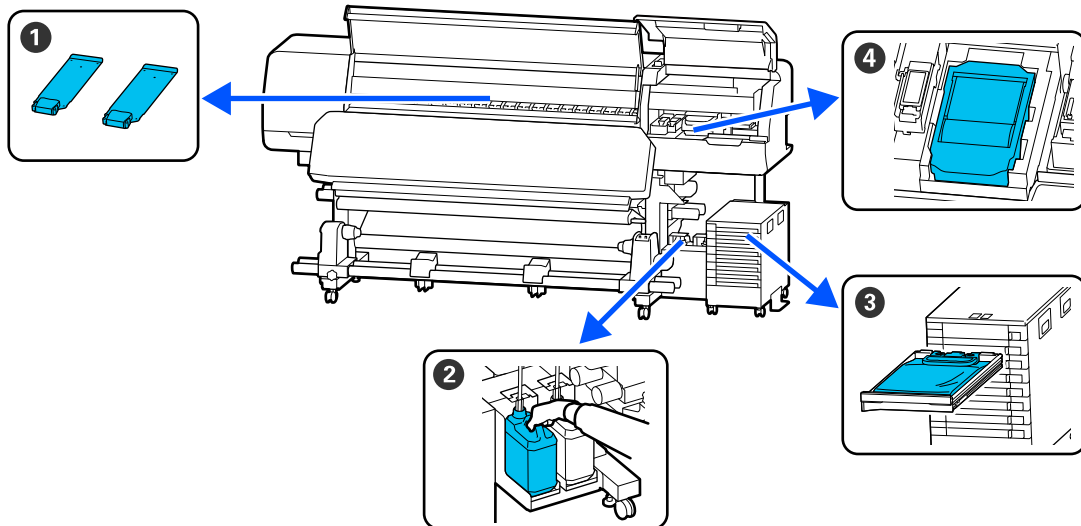

When to perform	Component to be replaced
When the plates are deformed or damaged.	<p>① Media edge plates  <a href="#">“Replacing the Media Edge Plates” on page 93</a></p>

## Maintenance

When to perform	Component to be replaced
When a replacement message is displayed on the control panel screen	<p>② Waste ink bottle  <a href="#">☞ "Disposing of Waste Ink" on page 89</a></p> <p>④ Wiper Unit  <a href="#">☞ "Replacing the Wiper Unit" on page 91</a></p>
When an error appears on the control panel screen indicating ink is expended	<p>③ Ink Supply Unit  <a href="#">☞ "Shaking and Replacing Ink Supply Units" on page 87</a></p>

## Other maintenance

When to perform	Operation
When the LED light on the ink unit flashes blue (once a week)	<p>Shaking the Ink Supply Unit  <a href="#">☞ "Shaking" on page 87</a></p>
<input type="checkbox"/> When checking if nozzles are clogged <input type="checkbox"/> When checking which colors are clogged <input type="checkbox"/> Horizontal stripes or tint unevenness (banding) are appeared.	<p>Print Head Nozzle Check  <a href="#">☞ "Print Head Nozzle Check" on page 95</a></p>
When a clog is found after checking for clogged nozzles	<p>Print Head Cleaning  <a href="#">☞ "Print Head Cleaning" on page 96</a></p>
When a message is displayed instructing you to clean the anti-drying caps	<p>Cleaning the anti-drying caps  <a href="#">☞ "Cleaning the anti-drying caps" on page 80</a></p>
When the printer will not be used for an extended period (and switched off)	<p>Keeping Preparation  <a href="#">☞ "Long-term Storage (Pre-storage Maintenance)" on page 97</a></p>
When dirt from rollers adheres to print outs	<p>Cleaning pressure rollers  <a href="#">☞ "Cleaning pressure rollers" on page 99</a></p>
When it is hard to see inside the printer	<p>Cleaning the inside surface of the printer cover  <a href="#">☞ "Cleaning the inside surface of the printer cover" on page 98</a></p>

## Maintenance

### What You'll Need

Ready the following items before beginning cleaning and replacement.

When the supplied parts have been completely used, purchase new consumables.

Prepare genuine ink supply units or maintenance parts when performing replacements.

 [“Options and Consumable Products” on page 128](#)

If your gloves have worn out, prepare commercially available nitrile gloves.

#### Protective eyeglasses (available in the market)

Protects your eyes against ink and cleaning liquid.

#### Mask (available in the market)

Protects your nose and mouth from ink and cleaning liquid.

#### Cleaning kit (supplied with the printer)

For general cleaning.

The following items are in the kit.

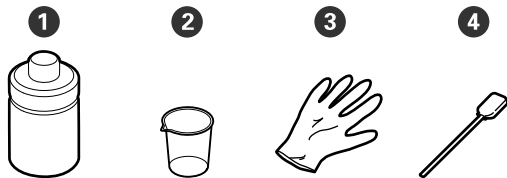

① Cleaning fluid (x1)

② Cup (x1)

③ Gloves (x16)

④ Cleaning stick (x50)

 [“Using Cleaning liquid” on page 78](#)

#### Metal or plastic (PP or PE) tray (available in the market)

Use when putting cleaning utensils, removed consumables, or cleaning fluid moved to the container supplied with the printer.

#### Media cleaner brush (supplied with the printer)

Use this when cleaning the media cleaner.

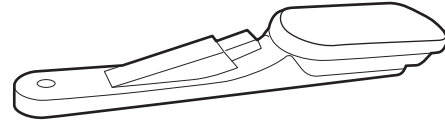

#### Soft cloth (commercially available)

Use when cleaning inside the printer. We recommend an item that is not likely to generate lint or static electricity.

## Maintenance

# Precautions regarding maintenance

Note the following points when cleaning and replacing parts.

### **Caution:**

- ❑ Store ink supply units, cleaning ink supply units, cleaning liquid, and waste ink out of the reach of children.
- ❑ During maintenance, wear protective clothing, including protective eyewear, gloves, and a mask.  
*If ink, waste ink, or cleaning liquid come into contact with your skin or enter your eyes or mouth, take the following actions.*
  - ❑ If fluid adheres to your skin, immediately wash it off using large volumes of soapy water. Consult a physician if the skin appears irritated or is discolored.
  - ❑ If fluid enters your eyes, rinse immediately with water. Failure to observe this precaution could result in bloodshot eyes or mild inflammation. If problems persist, consult with a physician.
  - ❑ If fluid enters your mouth, consult a physician immediately.
  - ❑ If fluid is swallowed, do not force the person to vomit, and consult with a physician immediately. If the person is forced to vomit, fluid may get caught in the trachea which can be dangerous.
- ❑ After replacing the waste ink bottle or using the cleaning liquid, wash your hands and gargle thoroughly.

- ❑ Remove the media from the printer before proceeding.
- ❑ Never touch the belts, circuit boards, or any parts that do not require cleaning. Failure to observe this precaution could result in malfunction or reduced print quality.
- ❑ Use only the supplied cleaning sticks or sticks contained in a maintenance kit. Other types of sticks that produce lint will damage the print head.

- ❑ Always use fresh cleaning sticks. Re-using sticks can make stains even harder to remove.
- ❑ Do not touch the tips of the cleaning sticks. Oil from your hands could damage the print head.
- ❑ Only use the specified cleaning liquid to clean around the print head or the suction cap. Using a liquid other than that specified could cause the printer to malfunction or print quality to decline.
- ❑ Touch a metallic object before starting work to discharge any static electricity.

## Performing Regular Cleaning

### Daily Cleaning

When lint, dust, or ink adheres to the platen heater or the media edge plates, it could cause clogged nozzles or ink drops to occur.

To maintain optimum printing quality, we recommend cleaning before starting work every day.

### **Caution:**

- ❑ The curing heater, heaters, and media edge plates may be hot; observe all necessary precautions. Failure to observe the necessary precautions could result in burns.
- ❑ Do not put your hand inside the curing heater. Failure to observe the necessary precautions could result in burns.
- ❑ Be careful not to trap your hands or fingers when opening or closing the printer cover. Failure to observe this precaution could result in injury.

### **Important:**

When cleaning the platen heater, do not use cleaning liquid. Failure to observe this precaution could result in damaged parts.

**Maintenance**

**1** Make sure the printer is turned off and the screen has turned off, and then unplug the power cable from the outlet.

Disconnect both of the power cables.

**2** Leave the printer for a minute.

**3** Open the printer cover.

**4** Soak a soft cloth in water, wring it out thoroughly, and then wipe off any ink, lint, or dust that has adhered to the platen heater and the right side of the platen.

Carefully remove lint and dust stuck in the groove of the platen.

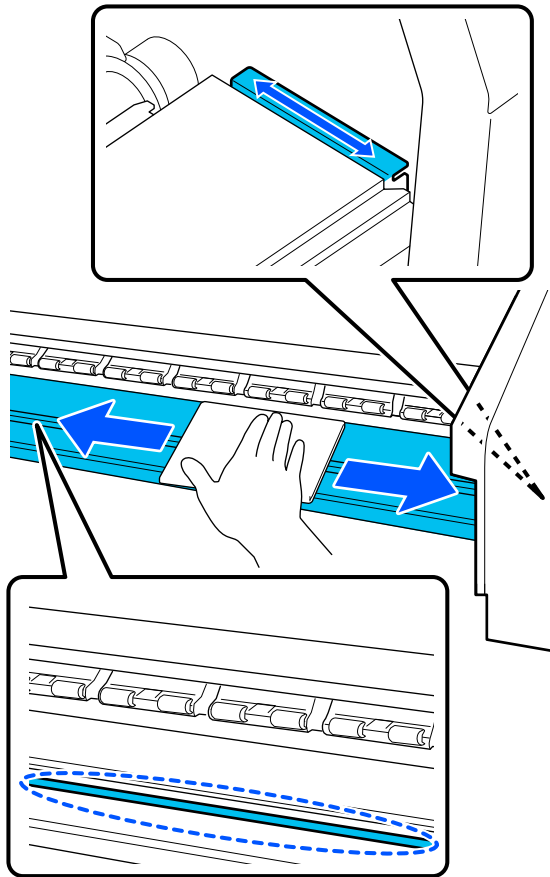

**5** Soak a soft cloth in water, wring it out thoroughly, and then wipe off any lint, or dust that has adhered to the media edge plates.

**! Important:**

*When media with glue has been used, wipe away glue using a diluted neutral detergent. If you continue printing while glue is stuck to the rear, it may rub against the print head.*

**When using media with glue and when ink adheres**

Remove the media edge plates from the printer, and clean the front and back of the plates.

When stains are removed, be sure to attach the plates to their original positions.

Removing and attaching the media edge plates [“Replacing the Media Edge Plates” on page 93](#)

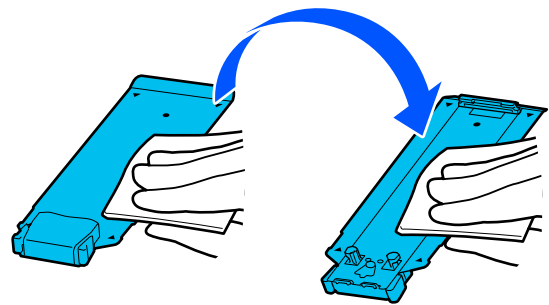

**Using Cleaning liquid**

Only use cleaning liquid to clean the parts indicated in the manual.

Before starting this procedure, be sure to read the following:

[“Precautions regarding maintenance” on page 77](#)

**1** Put the cup supplied with the Cleaning Kit on the tray, and pour approximately 10 ml (0.33 oz.) of cleaning liquid into the cup.

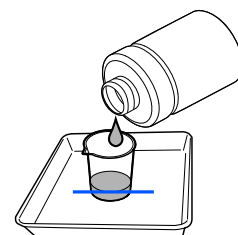

**Maintenance**

- 2** Dampen the cleaning stick with cleaning fluid.  
When doing this, do not allow cleaning liquid to drip from the cleaning stick.

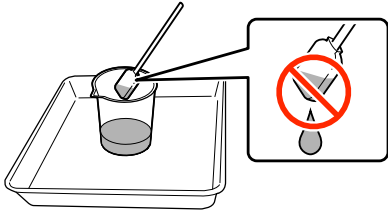

**! Important:**

- ❑ Do not use cleaning liquid that you have already used for cleaning to clean the next time. Using dirty cleaning liquid will make staining worse.
- ❑ Used cleaning liquid is industrial waste. Dispose of them in the same way as for waste inks.  
📖 [“Disposal of used consumables” on page 94](#)
- ❑ After using the cleaning liquid, tightly close the lid of the cleaning liquid and store it at room temperature out of direct sunlight and away from high temperatures or humidity.

**Cleaning Around the Print Head**

When a message is displayed on the control panel screen informing you that it is time to clean around the print head, follow the steps below to clean it.

Before starting this procedure, be sure to read the following:

📖 [“Precautions regarding maintenance” on page 77](#)

**! Important:**

When a message is displayed on the control panel screen informing you that it is time to clean around the print head, clean it immediately. Print quality will decline if you continue to use the printer.

- 1** Press **Start** when a message is displayed on the control panel screen informing you that it is time to clean the area around the print head.

The print head moves to the maintenance position on the left.

- 2** Make sure there is a notification on the screen asking you to open the maintenance cover, and then open the maintenance cover on the left.

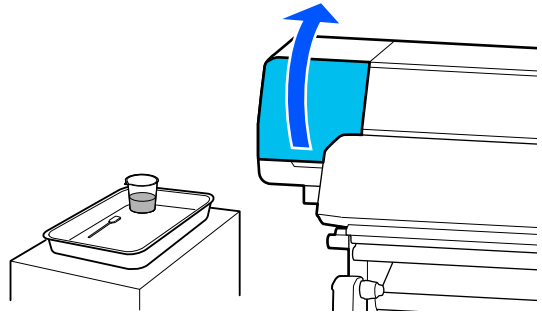

- 3** Check if the area around the print head is dirty. If the area is dirty as shown in the photo, it needs to be cleaned. Go to step 4.

If it is not dirty, then proceed to step 8.

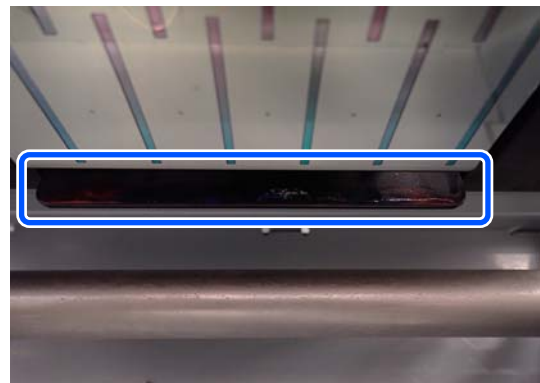

- 4** Dampen the cleaning stick with cleaning fluid. Use new cleaning sticks and cleaning fluid.  
📖 [“Using Cleaning liquid” on page 78](#)

## Maintenance

- 5** Wipe off any ink, lint, and dust stuck to the sides (four sides) and the corners of the plate as shown in the illustration.

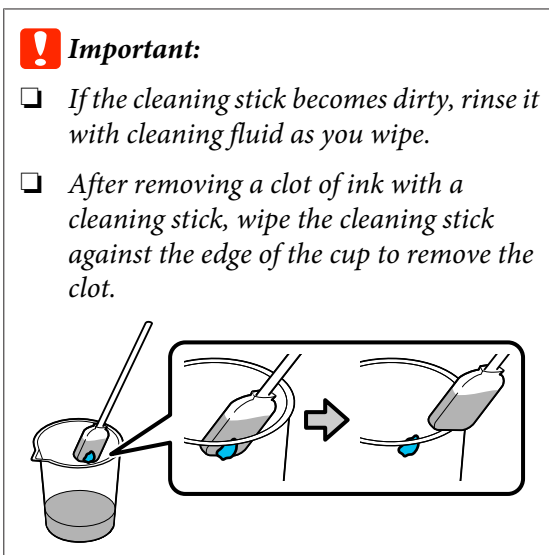
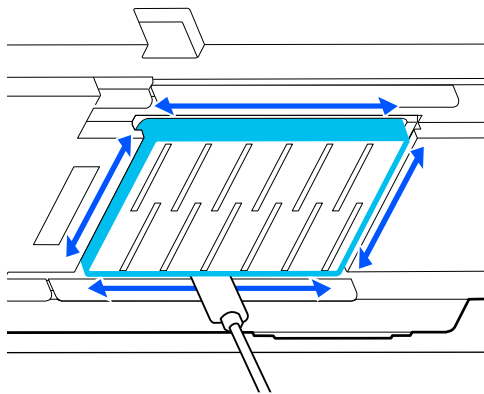
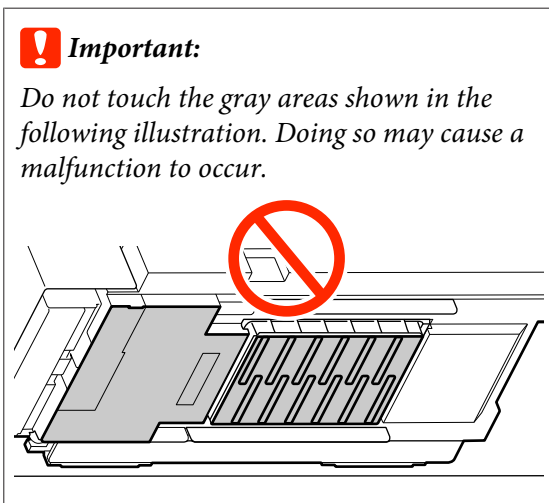

- 6** Wipe off any ink, lint, and dust from the front and back of the parts that are indicated by    in the following illustration.

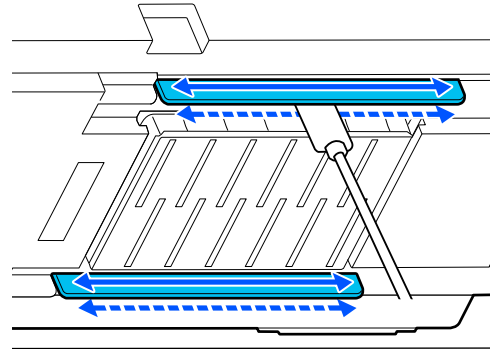

- 7** Check that it is clean as shown in the photo.

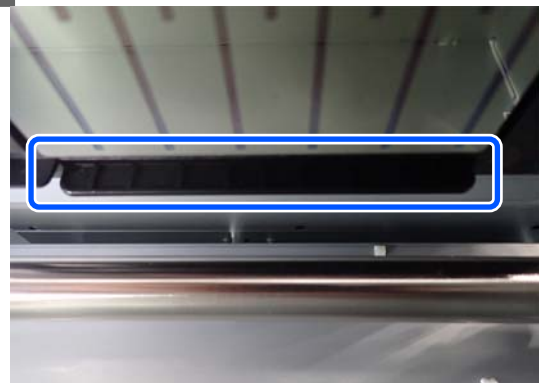

- 8** Close the left maintenance cover.

- 9** On the control panel screen, press **Done**.  
Cleaning around the print head is complete.

## Cleaning the anti-drying caps

When a message is displayed on the control panel screen informing you that it is time to clean the anti-drying caps, follow the steps below to clean them.

Before starting this procedure, be sure to read the following:

[“Precautions regarding maintenance” on page 77](#)

- 1** Press **Start** when a message is displayed on the control panel screen informing you that it is time to clean the anti-drying caps.

The print head moves to the maintenance position on the left.



**Maintenance**

- 2** Open the right maintenance cover.

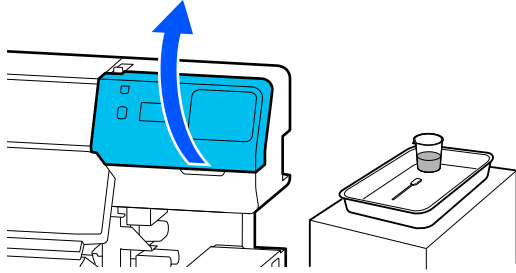

- 3** Check if the anti-drying caps are dirty.  
 If the area is dirty as shown in the photo, it needs to be cleaned. Go to step 4.  
 If it is not dirty, then proceed to step 11.



- 4** Dampen the cleaning stick with cleaning fluid.  
 ☞ [“Using Cleaning liquid” on page 78](#)

- 5** Hold the cleaning stick flat and wipe the top edges of the cap.  
 Repeat steps 4 to 7 for the two caps aligned in the opposite direction.

**! Important:**  
 Do not touch the holes in the caps when cleaning. The cleaning fluid may get into the hole, causing the cap to not function correctly.

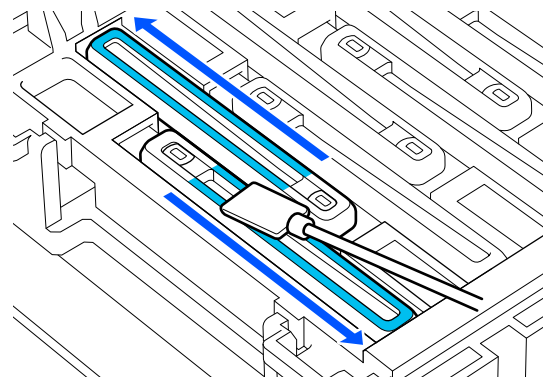

- 6** Hold the cleaning stick in a perpendicular orientation, and wipe the inside of the cap.  
 While wiping, avoid the area around the hole inside the cap and move the cleaning stick only in the direction away from the hole.

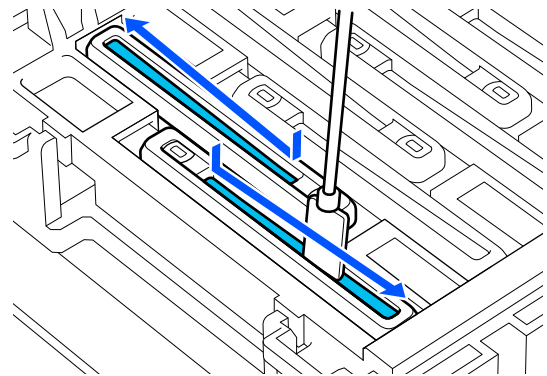

**Maintenance**

**When there is lint or dust on the cap**

Remove it by using the tip of the cleaning stick.

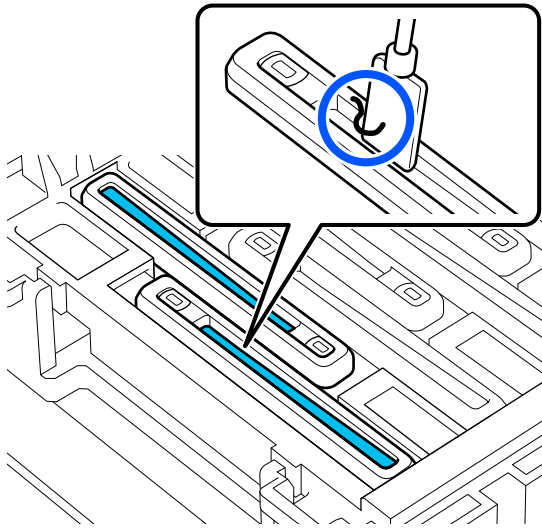

- 7** Hold the cleaning stick in a perpendicular orientation, and wipe the outer area of the cap that needs to be cleaned.

While wiping, avoid the area around the hole inside the cap.

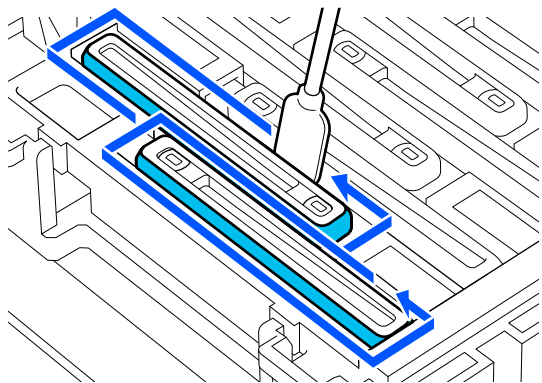

- 8** Rinse the cleaning stick used for cleaning in the cup containing the cleaning liquid.

After rinsing the stick, use the rim of the cup to wipe off excess liquid so that it does not drip from the cleaning stick.

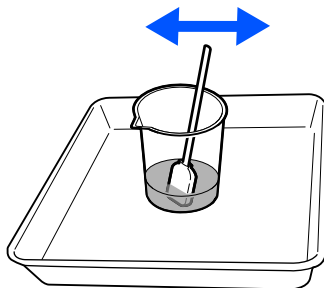

- 9** Clean the next dirty anti-drying caps. Repeat steps 5 to 8 to clean the rest of the dirty anti-drying caps.

Once all of the anti-drying caps are clean, proceed to step 10.

- 10** Use a new dry cleaning stick to wipe up all the ink and cleaning liquid on the edges, the inside, and the outside of the cap.

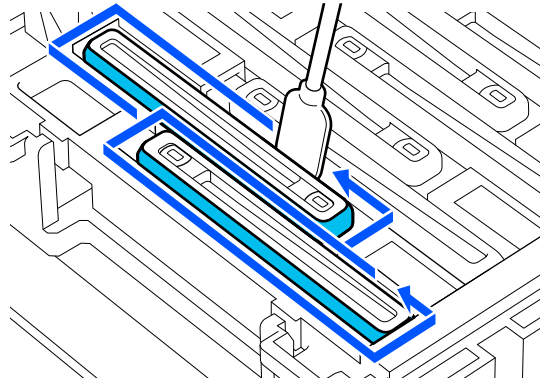
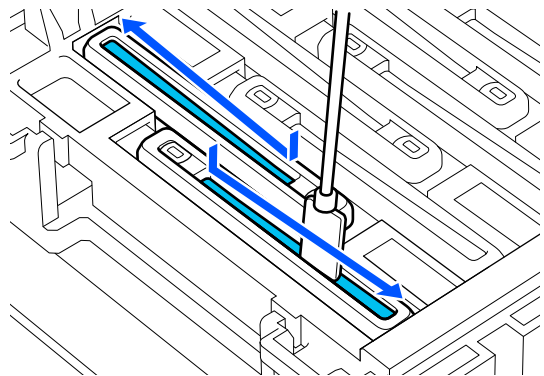
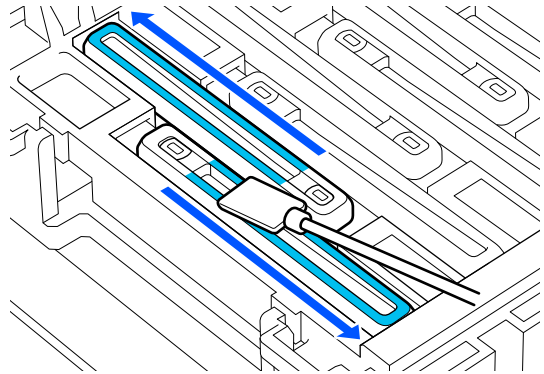

## Maintenance

Cleaning is complete when you have wiped up all the ink and cleaning fluid, leaving no residue, as shown in the illustration below. If any ink or cleaning fluid is left over, it could clog the nozzles.



- 11 Close the right maintenance cover.
- 12 On the control panel screen, press **Complete**.  
Cleaning the anti-drying caps is complete.

### Cleaning the Suction Cap

When a message is displayed on the control panel screen informing you that it is time to clean the suction cap, follow the steps below to clean it.

Before starting this procedure, be sure to read the following:

[“Precautions regarding maintenance” on page 77](#)

- 1 Press **Start** when a message is displayed on the control panel screen informing you that it is time to clean the suction cap.  
  
The print head moves to the maintenance position on the left.
- 2 Open the right maintenance cover.

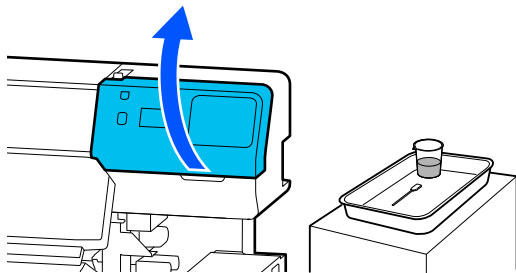

- 3 Check if the suction cap is dirty.  
If the area is dirty as shown in the photo, it needs to be cleaned. Go to step 4.  
If it is not dirty, then proceed to step 9.

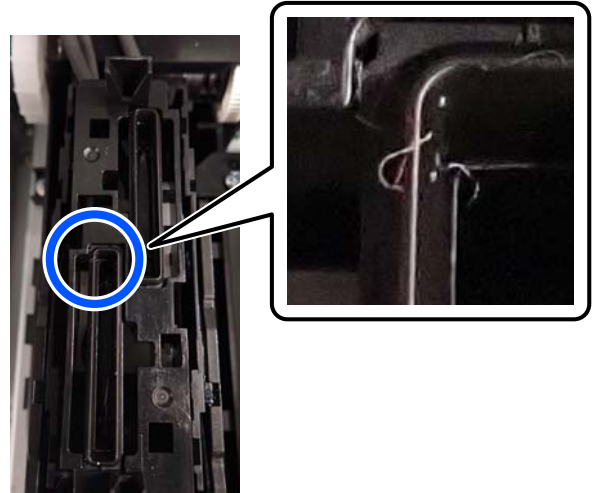

- 4 Dampen the cleaning stick with cleaning fluid.  
Use new cleaning sticks and cleaning fluid.  
 [“Using Cleaning liquid” on page 78](#)
- 5 Hold the cleaning stick in a perpendicular orientation, and wipe the outer areas of all the caps.

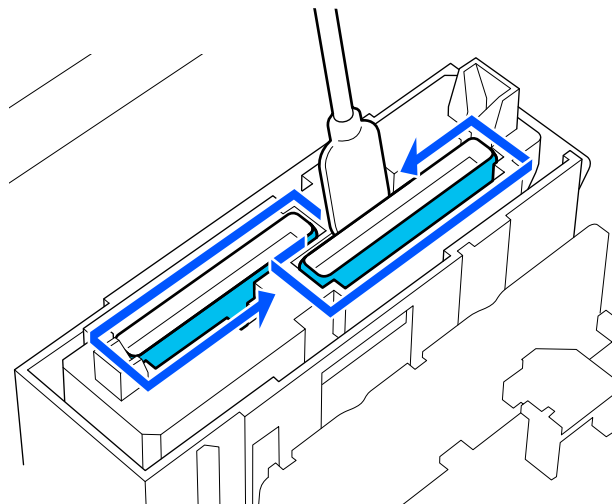

**Maintenance**

- 6** Hold the cleaning stick flat and wipe the top edges of all of the caps.

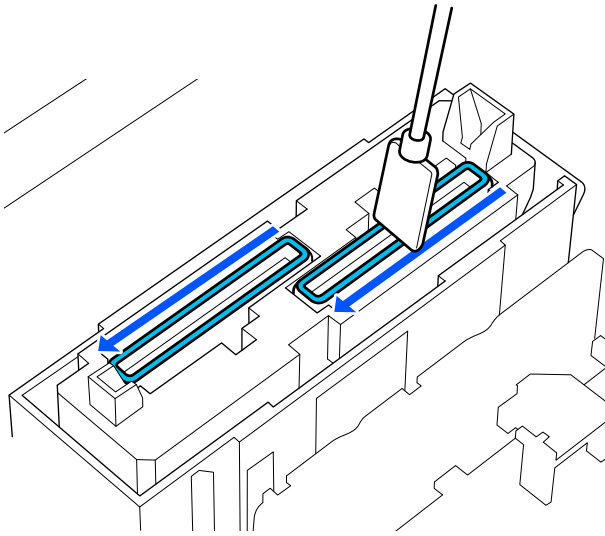

- 7** Hold the cleaning stick in a perpendicular orientation, and wipe the inside of the guide section.

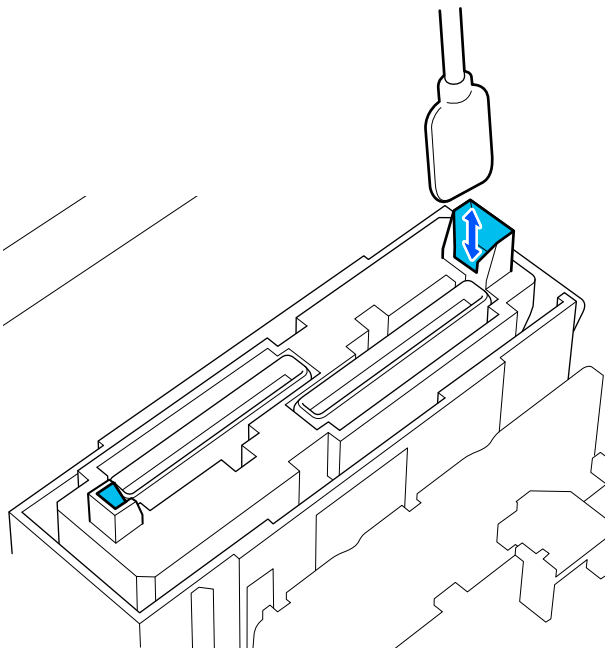

- 8** Check that it is clean as shown in the photo.

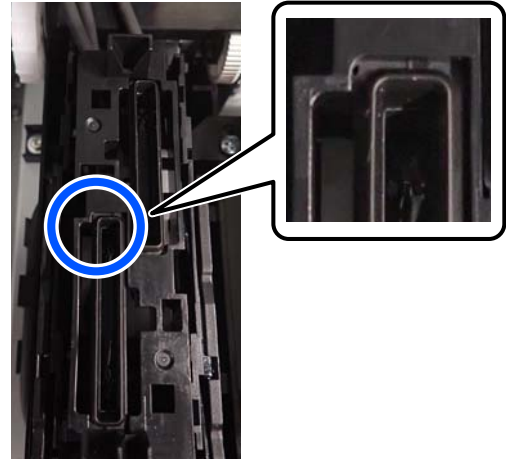

- 9** Close the right maintenance cover.

- 10** On the control panel screen, press **Done**.  
Cleaning the suction cap is complete.

**Cleaning Around the Flushing Pad**

When a message is displayed on the control panel screen informing you that it is time to clean around the flushing pad, follow the steps below to clean it.

Before starting this procedure, be sure to read the following:

[“Precautions regarding maintenance” on page 77](#)

- 1** Press **Start** when a message is displayed on the control panel screen informing you that it is time to clean around the flushing pad.
- 2** Open the right maintenance cover.

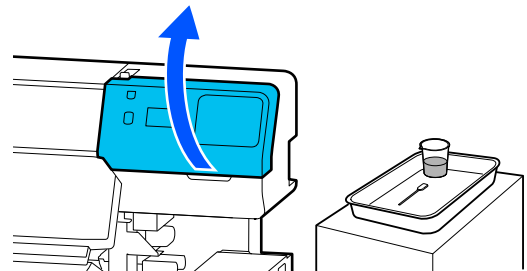

**Maintenance**

- 3** Check if the edges of the flushing pad and the rails on the left and right are dirty.  
If the area is dirty as shown in the photo, it needs to be cleaned. Go to step 4.  
If it is not dirty, then proceed to step 9.

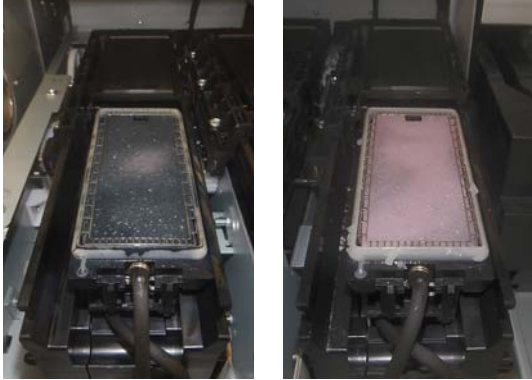

- 4** Dampen the cleaning stick with cleaning fluid.  
Use new cleaning sticks and cleaning fluid.  
[👉 “Using Cleaning liquid” on page 78](#)
- 5** Use the tip of the cleaning stick to wipe off any ink, lint, and dust that has stuck to the parts that are indicated by   in the following image.

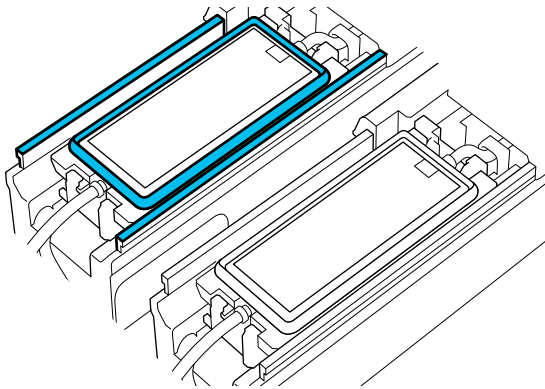

- 6** Rinse the cleaning stick used for cleaning in the cup containing the cleaning liquid.  
After rinsing the stick, use the rim of the cup to wipe off excess liquid so that it does not drip from the cleaning stick.

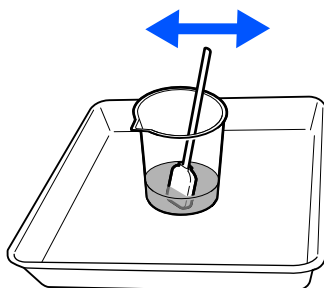

- 7** Use the tip of the cleaning stick to wipe off any ink, lint, and dust that has stuck to the parts that are indicated by   in the following image.

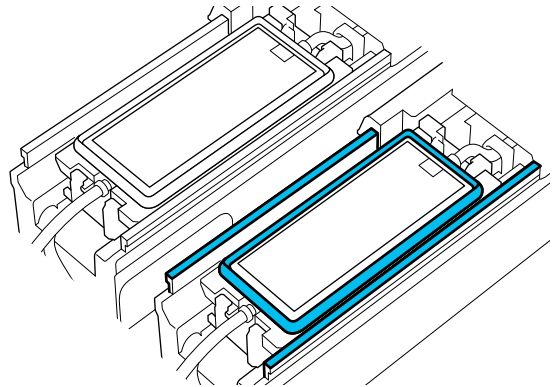

- 8** Check that it is clean as shown in the photo.

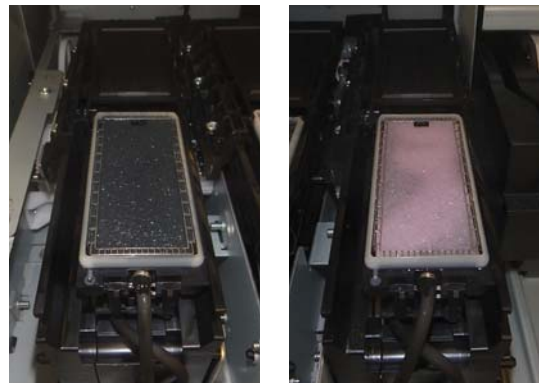

- 9** Close the maintenance cover.
- 10** On the control panel screen, press **Done**.  
Cleaning around the flushing pad is complete.

---

**Cleaning the Media Cleaner**

If the media cleaners are dirty, they cannot sufficiently wipe dirt and dust off the surface of the media, which may lead to problems such as clogged nozzles.

If the message **Clean the media cleaner. After cleaning is complete, press [OK].** is displayed on the control panel's screen, use the supplied media cleaner brush to clean them.

## Maintenance

- 1 Check the message on the screen, and then make sure that the media loading lever is flipped forward.

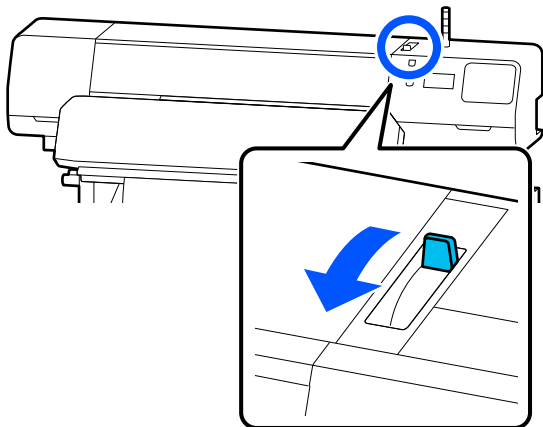

- 2 Go to the back of the printer and remove the Media Cleaner.

While pressing the tabs on both sides, pull it straight out.

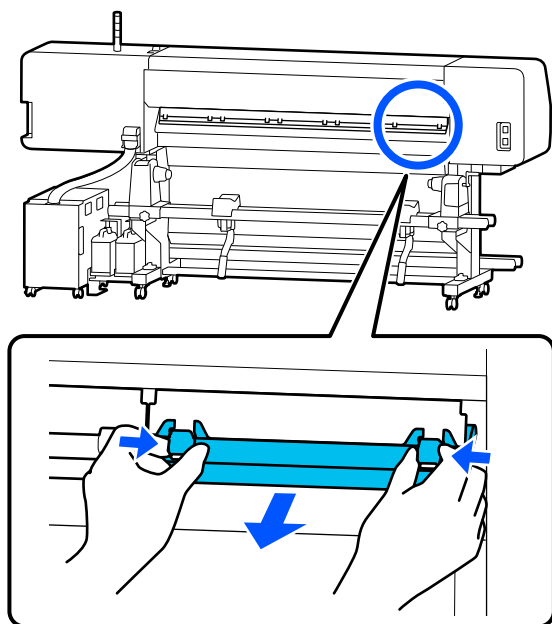

- 3 Use the supplied media cleaner brush to brush dirt and dust from the surface in one direction. The surface of the brush has a brushing direction. If it becomes dusty again after brushing, try brushing in the opposite direction.

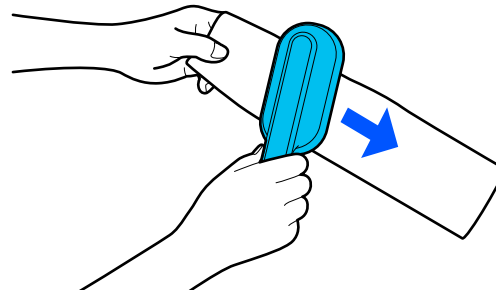

**Note:**  
You can switch the direction in which to wipe.

- 4 When you finish cleaning a media cleaner, install it back into the printer.

Hold the tabs as you insert the media cleaner until you hear a click.

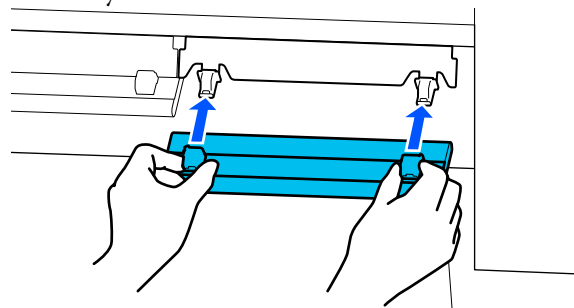

- 5 Repeat Steps 2 to 4 to clean all of the media cleaners.

- 6 When cleaning is complete, press **Done** on the screen.

# Shaking and Replacing Ink Supply Units

## Shaking

### Timing and frequency of shaking

**!** **Important:**

Due to ink characteristics, the ink supply units of this printer are prone to sedimentation (components settling to the bottom of the liquid). If ink settles, tint unevenness and nozzle clogs occur.

Shake a new ink supply unit before installing it. After installing it in the ink unit, remove and shake it periodically.

- When replacing

Approx. 10 times in 10 seconds

You do not need to shake the OP, ML, or cleaning ink supply units.

- Once every week  
Remove any tray whose LED light is flashing blue, and then shake the ink supply unit tray. To maintain print quality, do not continue using them when they are flashing blue.

Approx. 5 times in 5 seconds

### Shaking method

- 1 Make sure the printer is on, and then pull the ink supply unit tray that needs to be shaken out of the ink unit.

Any ink supply unit whose LED light is flashing blue needs to be shaken.

**!** **Important:**

Place your hand on the bottom of the ink supply unit tray while removing it. If you use only one hand, the weight of the ink supply unit tray may cause it to fall, and be damaged, as you remove it.

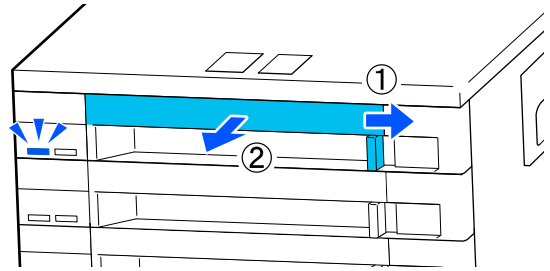

**Note:**

While the ink supply unit tray is pulled out, check the ink supply ports of the ink supply units. If ink has dripped from the port or accumulated at the bottom as shown in the photo, wipe it off using a cleaning stick.



Do not touch the ink supply ports while wiping.

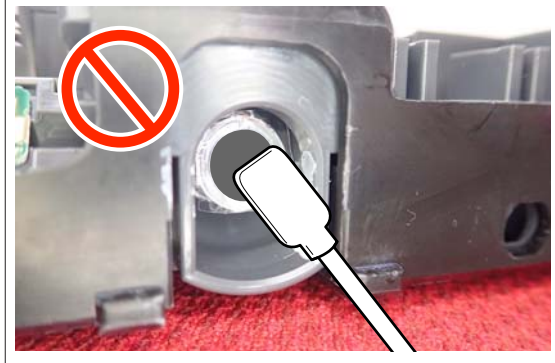

- 2 While the ink supply unit is in the ink supply unit tray, as shown in the illustration below, shake it thoroughly by tilting it up and down at about a 60 degree angle 5 times in 5 seconds.

You do not need to shake the OP, ML, or cleaning ink supply units.

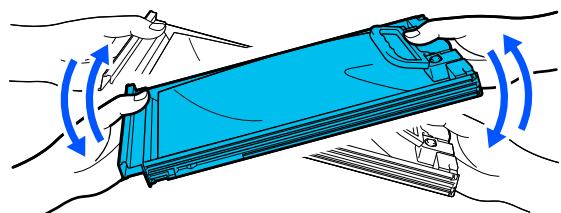

Maintenance

**! Important:**

- Do not forcefully shake or swing ink supply units or ink supply unit trays holding an ink supply unit. Ink could leak.

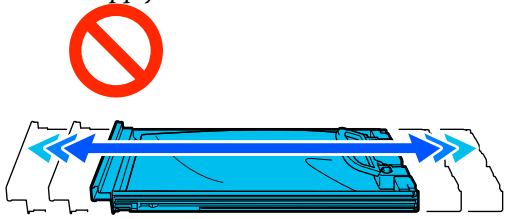

- Removed ink supply units may have ink around the ink supply port, so be careful not to get any ink on the surrounding area when removing the ink supply units.

Replacement procedure

**! Important:**

Epson recommends the use of genuine Epson ink supply units. Epson cannot guarantee the quality or reliability of non-genuine ink. The use of non-genuine ink may cause damage that is not covered by Epson's warranties, and under certain circumstances, may cause erratic printer behavior. Information about non-genuine ink levels may not be displayed, and use of non-genuine ink is recorded for possible use in service support.

SC-R5000 Series

If one of the installed ink supply units is expended, printing cannot be performed. If ink is expended while printing, you can continue printing after replacing the ink supply unit. If you continue to use an ink supply unit that is running low, you may need to replace the ink supply unit while printing. If you replace it while printing, colors may look different depending on how the ink dries. If you want to avoid issues such as this, we recommend replacing the ink supply unit before printing. You can still use the removed ink supply unit in the future until the ink supply unit is expended.

The following procedure explains how to replace ink supply units and cleaning ink supply unit.

SC-R5000L Series

When ink is expended, the ink supply automatically switches to another ink supply unit of the same color. Since printing continues as it is, replace the ink supply unit for which ink is expended while there is still enough ink remaining in the ink supply unit that is currently operating. If one ink supply unit is operating, you can replace the other ink supply unit while printing. You cannot print if the amount of ink remaining in both ink supply units of the same color is expended.

The following procedure explains how to replace ink supply units and cleaning ink supply unit.

- 1 Make sure the printer is on.
- 2 Pull the ink supply unit tray of the ink supply unit you want to replace out of the ink unit.

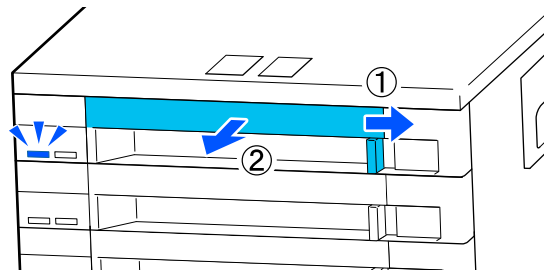

- 3 Remove the ink supply unit from the ink supply unit tray.

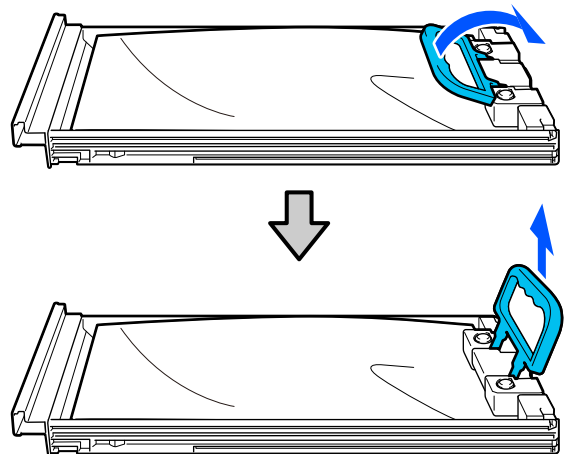

**! Important:**

Removed ink supply units may have ink around the ink supply port, so be careful not to get any ink on the surrounding area when removing the ink supply units.



Maintenance

- 4 Place the new ink supply unit into the ink supply unit tray, and then lower the handle.

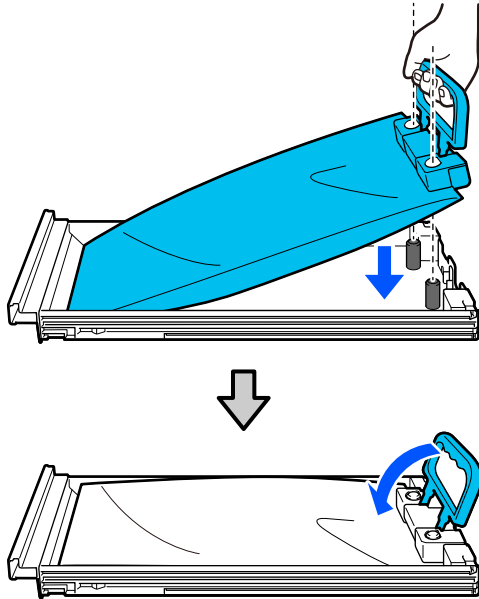

- 5 While the ink supply unit is in the ink supply unit tray, as shown in the illustration below, carefully shake it by tilting it up and down at about a 60 degree angle 10 times in 10 seconds.

You do not need to shake the OP, ML, or cleaning ink supply units.  
If you are instructed to shake it after attaching to the ink unit, shake it thoroughly 5 times in 5 seconds.

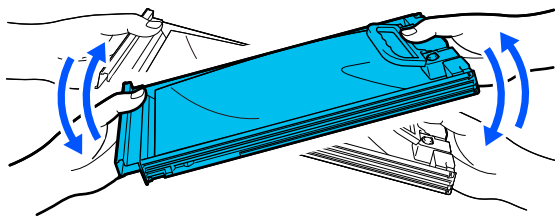

- 6 Match the color on the label on the ink supply unit with the label on the ink unit, and then fully insert the ink supply unit tray.

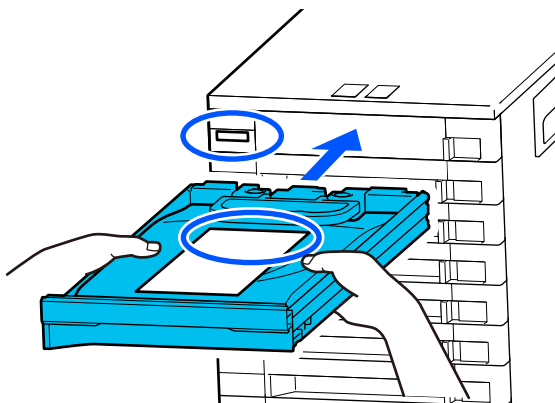

- 7 Move the lock switch to the left to lock it.

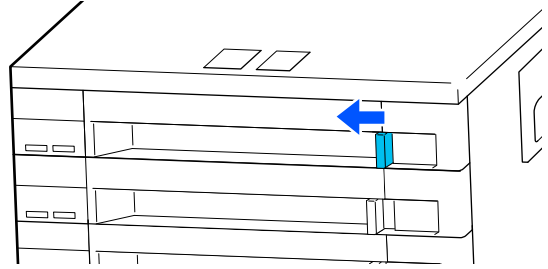

Repeat steps 2 to 7 to replace other ink supply units.

**Important:**

Place ink supply units in all the ink supply unit trays, and then insert them into the ink unit. Printing is not possible or a malfunction may occur if, for even one color, an ink supply unit is not loaded into an ink supply unit tray or an ink supply unit tray is not inserted into the ink unit.

Disposing of ink supply units ↗ [“Disposal of used consumables” on page 94](#)

## Disposing of Waste Ink

### Preparing and Replacement Timing

**When the message "The waste ink bottle is nearing the end of its service life. Prepare a new one. You can continue printing until replacement is required." is displayed**

Prepare a new Waste Ink Bottle as soon as possible.

When you want to replace the waste ink bottle specified in the message at this stage due to night operations and so on, select **Replace Waste Ink Bottle** from the Settings menu, and then replace the bottle. If you perform the replacement without selecting **Replace Waste Ink Bottle**, the waste ink counter will not operate correctly.

Maintenance menu ↗ [“Maintenance menu” on page 118](#)

Waste Ink Counter ↗ [“Waste Ink Counter” on page 90](#)

Maintenance

**Important:**

During printing or while the printer is running the operations shown below, do not remove the Waste Ink Bottle unless instructed to do so by the on-screen instructions. Failure to observe this precaution could cause ink to leak.

- Print Head Cleaning
- Keeping Preparation

**"Waste Ink Bottle is at the end of its service life." is displayed**

Replace the waste ink bottle indicated in the message with a new one immediately.

Replacement procedure [↗](#) ["Replacing the Waste Ink Bottle" on page 90](#)

**Waste Ink Counter**

The printer uses the waste ink counter to track waste ink and displays the following message when the counter reaches the warning level. **Waste Ink Bottle is at the end of its service life.** If you replace the waste ink bottle when this message is displayed, the counter is cleared automatically.

If you need to replace the waste ink bottle before the message is displayed, select **Replace Waste Ink Bottle** from the setup menu.

Maintenance menu [↗](#) ["Maintenance menu" on page 118](#)

**Important:**

If you replace the Waste Ink Bottle before being prompted by a message, always clear the waste ink counter. Otherwise, the replacement interval for the Waste Ink Bottle will no longer be notified correctly from the next message.

**Replacing the Waste Ink Bottle**

Follow the procedure below to replace the parts.

Before starting this procedure, be sure to read the following:

[↗](#) ["Precautions regarding maintenance" on page 77](#)

- 1** Check the labels for the waste ink bottle indicated in the message, and then remove it from the waste ink bottle holder.

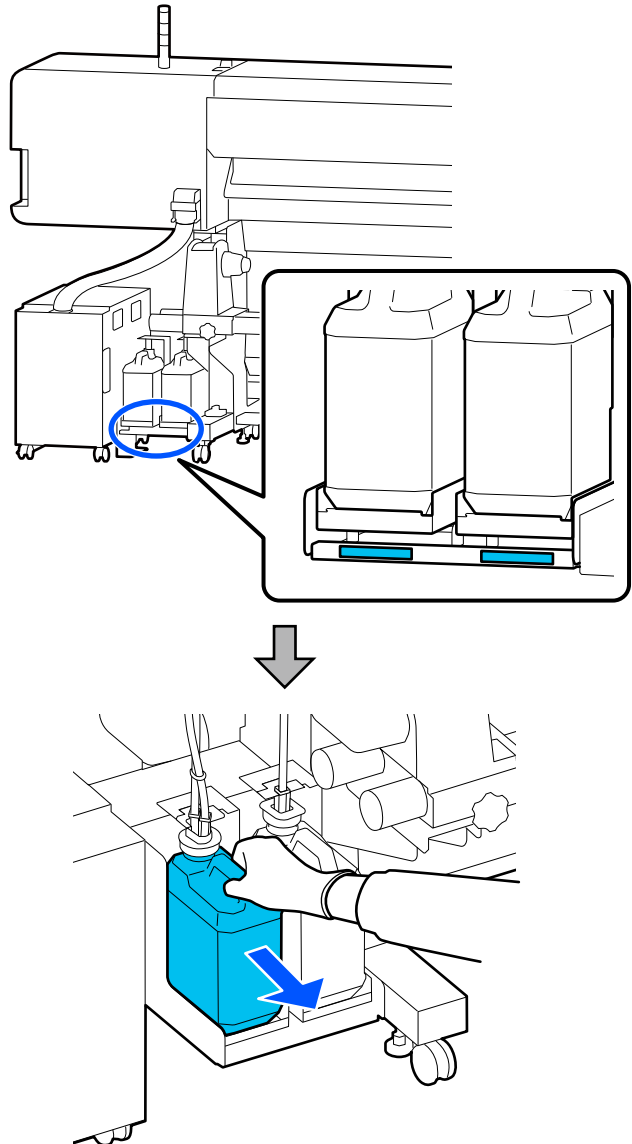

Maintenance

- 2 Insert the waste ink tube into the mouth of the new waste ink bottle and place it in the waste ink bottle holder.

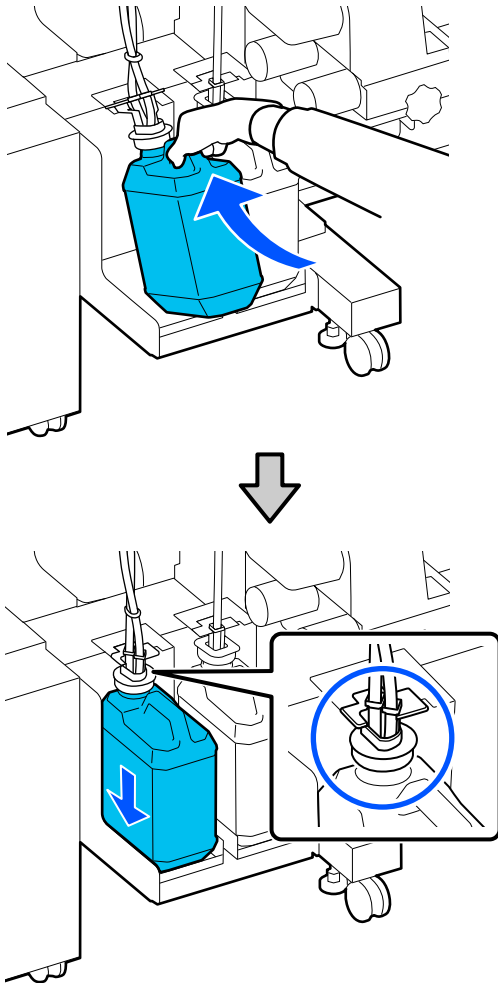

Tightly seal the lid on the used Waste Ink Bottle.

**! Important:**  
 You will need the lid for the Waste Ink Bottle when disposing of waste ink. Keep the lid in a safe place; do not throw it out.

- 3 Press OK.

- 4 Check again to confirm that the new waste ink bottle is placed correctly, and then press **Complete** to reset the waste ink counter.

**! Important:**  
 Be sure to confirm that the waste ink tube is inserted in the mouth of the waste ink bottle. Ink will spill onto the surrounding area if the tube is not inserted in the bottle.

Leave the waste ink in the Waste Ink Bottle for disposal; do not transfer it to another container.

**Note:**  
 Note the following points when transferring waste ink from the Waste Ink Bottle to another container.

- ❑ Use a container made of PE (polyethylene) when transferring the waste ink.
- ❑ Attach the spout included with the printer to the rim of the Waste Ink Bottle and transfer the waste ink.
- ❑ Pour the waste ink carefully. Pouring the waste ink quickly may cause it to spill and splatter.
- ❑ Securely close the lid of the container to which you transferred the waste ink and store it in a location that is not exposed to open flames.
- ❑ Mixing waste ink from color ink and from OP is not toxic. However, if they are mixed they will solidify and sedimentation will occur.

Disposing of used waste ink and Waste Ink Bottle "Disposal of used consumables" on page 94

## Replacing the Wiper Unit

### Preparing and Replacement Timing

**The Wiper Unit is nearing the end of its service life. is displayed**

Prepare a new wiper unit as soon as possible.

Maintenance

When you want to replace the parts at this stage due to night operations and so on, select **Replace Wiper Unit** from the setup menu, and then replace the parts. If you perform the replacement without selecting **Replace Wiper Unit**, the maintenance parts counter will not operate correctly.

Maintenance menu  [“Maintenance menu” on page 118](#)

 **Important:**

**Maintenance Counter**

*The printer tracks amounts consumed using the maintenance counter and displays a message when the counter reaches the warning level.*

*When the message **Wiper Unit is at the end of its service life.** is displayed, if you replace the wiper unit, the counter is cleared automatically.*

*If you need to replace the parts before the message is displayed, select **Replace Wiper Unit** from the setup menu.*

Maintenance menu  [“Maintenance menu” on page 118](#)

**When the message Wiper Unit is at the end of its service life. is displayed**

Replace the wiper unit. Printing cannot be performed if the parts are not replaced.

Make sure you use the wiper unit for this printer.

 [“Options and Consumable Products” on page 128](#)

Before starting this procedure, be sure to read the following:

 [“Precautions regarding maintenance” on page 77](#)

**Replacing the Wiper Unit**

**1** When the message is displayed, press the OK button.

**2** Open the right maintenance cover.

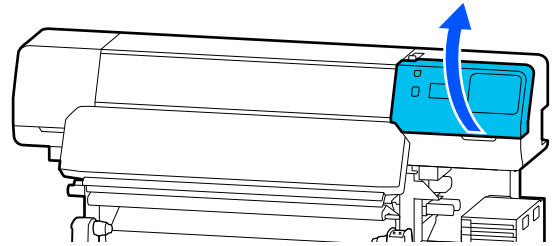

**3** Hold the tabs on the front and back of the wiper unit, and lift the wiper unit straight up to remove it.

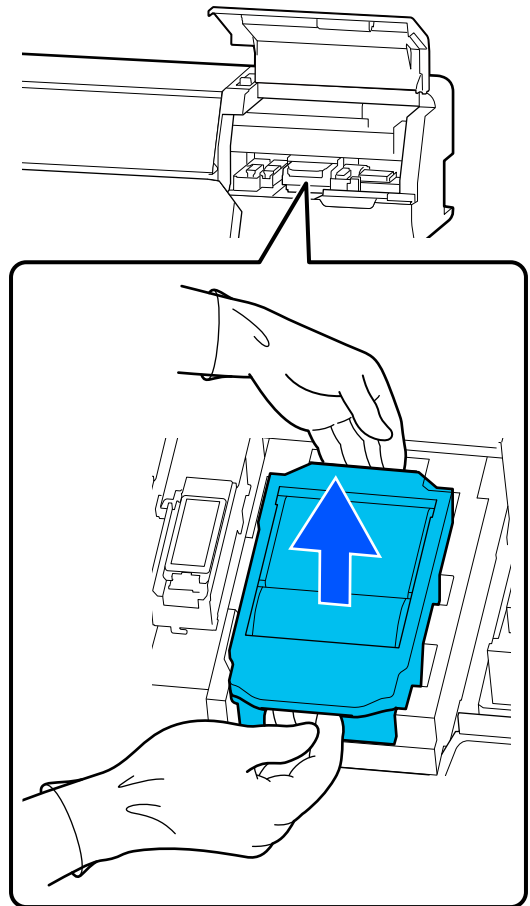

**4** To avoid soiling your surroundings with ink, wrap the used wiper unit in the packaging supplied with the new wiper unit.

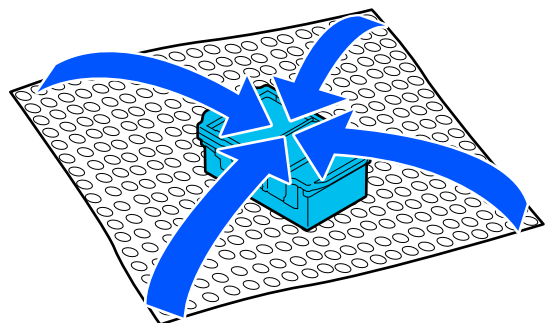

**Maintenance**

- 5** Insert the new wiper unit.

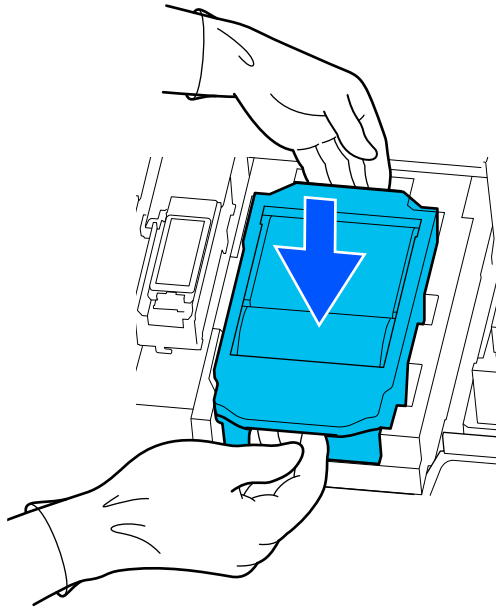

- 6** Close the maintenance cover.
- 7** Check the on-screen message, and then press **Yes**.  
The maintenance counter is cleared.

Disposing of used wiper units [“Disposal of used consumables” on page 94](#)

## Replacing the Media Edge Plates

If the media edge plates supplied with the printer become deformed or damaged, be sure to replace them with new ones.

Media edge plates available for this printer

[“Options and Consumable Products” on page 128](#)

**! Important:**  
If you continue to use the printer with a deformed or damaged media edge plate, the print head could be damaged.

- 1** Remove media, and turn off the printer. Check that the screen display has turned off, and then unplug the power cable from the outlet.  
 [“Removing the Take-up Roll” on page 66](#)  
Disconnect both of the power cables.

- 2** Unplug the printer and wait for a minute before opening the left maintenance cover and the printer cover.

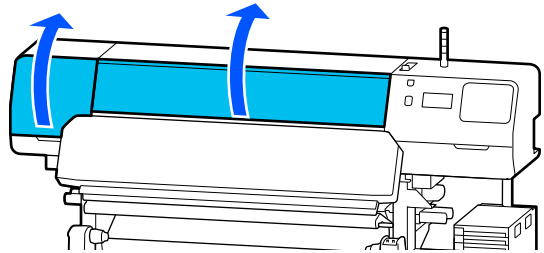

- 3** While holding the tabs of the media edge plate on both sides, move the plate to the left edge of the platen to remove it.  
When replacing the right media edge plate, remove the left side first, and then remove the right.

**! Important:**  
Be sure to remove the media edge plate from the left edge of the platen. Removing the plate from the right may cause a malfunction.

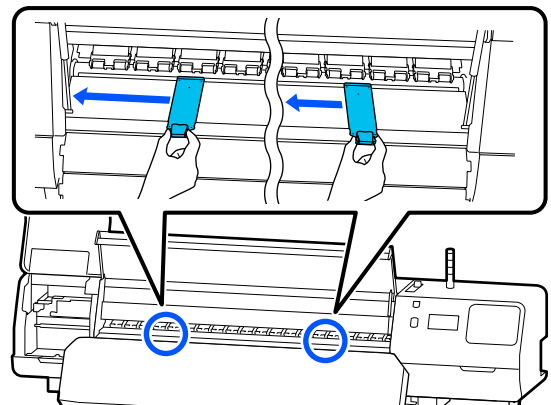

Maintenance

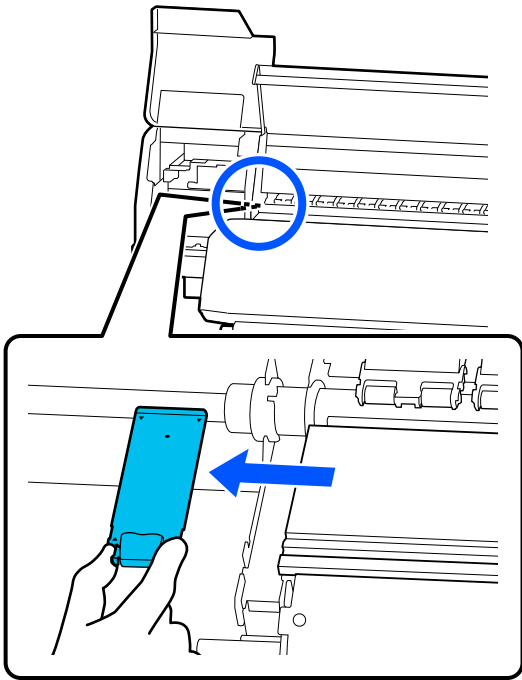

**4** Insert a new media edge plate into the left edge of the platen.

**! Important:**

You cannot insert the media edge plates from the right.

Align the platen rail with the ▲ holes for the media edge plates and insert as shown below.

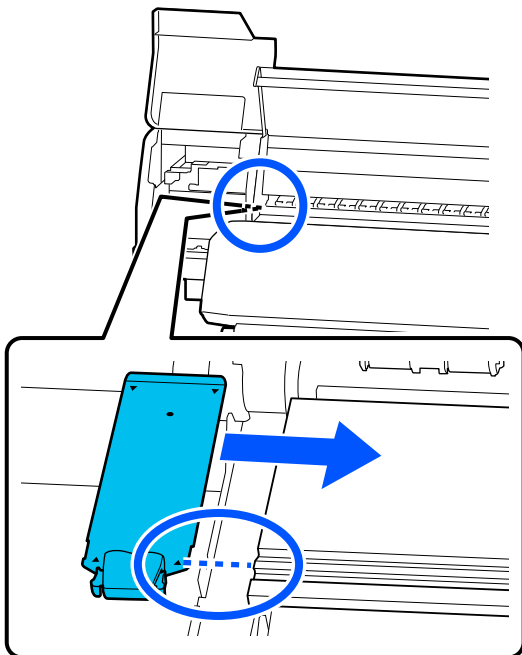

**5** Check that two hooked sections at the rear of the media edge plate are securely applied as shown below and that they are attached with no gap between the platen and media edge plate.

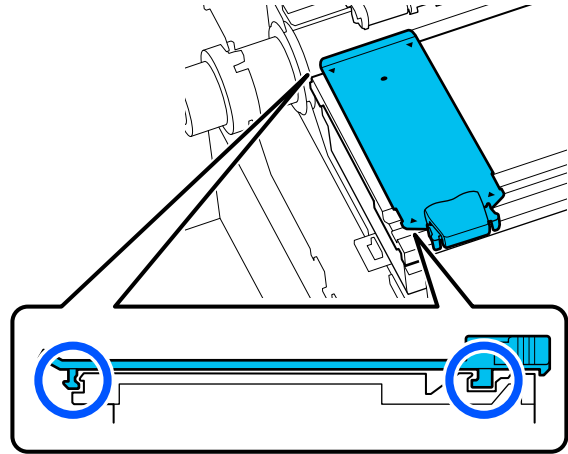

**! Important:**

If hooked sections are not positioned correctly, return to Step 3 to attach them again. Otherwise, the head may be damaged.

**6** While holding the tabs of each media edge plate on both sides, move both the plates to the left and right edges of the platen respectively.

Releasing the tab fixes the media edge plate.

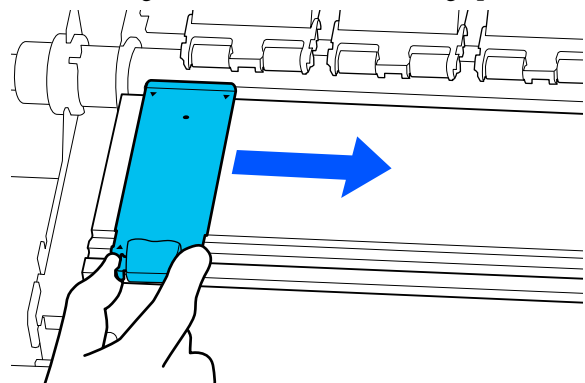

**7** Close the left maintenance cover and printer cover.

## Disposal of used consumables

The following used parts with adhered ink are classified as industrial waste.

## Maintenance

- Cleaning stick
- Clean-room wiper
- Cleaning liquid
- Waste ink
- Waste Ink Bottle
- Wiper Unit
- Media after printing
- Empty ink supply unit

Dispose of items according to local laws and regulations. For example, contract a industrial waste disposal company for disposal. In such cases, submit the "Safety data sheet" to the industrial waste disposal company.

You can download it at your local Epson Web site.

## Print Head Nozzle Check

We recommend that you check the print head nozzles for clogs each time before you print to ensure quality results.

### Types of Nozzle Checks

There are the following two ways to check the print head for clogged nozzles.

#### On-Demand Nozzle Pattern

If you want to check the condition of the nozzles before printing, or if you see stripes or unevenness in the print results, you can print out a check pattern and visually check it to see the condition of the nozzles.

See the following for details.

[🔗 "How to Print a Nozzle Check Pattern" on page 95](#)

Depending on the width of the loaded media, you can save media by printing additional test patterns in the space beside an existing pattern:

- If the width is 51 to 64 inches, up to three patterns can be printed (one on the left, one in the center, and one on the right).
- If the width is equal to or greater than 34 inches but less than 51 inches, up to two patterns can be printed (one on the left and one on the right).
- If the width of the media is less than 34 inches, you cannot print side by side.

#### Nozzle Check between Pages

When printing for the set number of pages\* is complete, the next page is printed across the printed check pattern. When all printing is complete, you can visually inspect the pattern to determine whether there may be faint or missing colors in the preceding or following printout.

[🔗 "General Settings menu" on page 106](#)

- \* Print jobs that do not include multiple pages are counted as one page.

## How to Print a Nozzle Check Pattern

- 1** Check that the printer is ready to print, and then press  (Menu) - **Maintenance - Print Head Nozzle Check**.
- 2** Select the desired print position, and then press **Start**.  
The check pattern is printed and cured.
- 3** Check the check pattern. Cut the media as necessary.

#### Example of clean nozzles

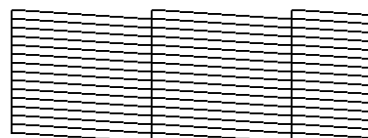

If there are no gaps in the check pattern, press [O].

## Maintenance

### Example of clogged nozzles



If there are gaps in the nozzle check pattern, press [X], and then perform Print Head Cleaning.

[“Print Head Cleaning” on page 96](#)

## Print Head Cleaning

### Types of Cleaning

The following two types of Print Head Cleaning are available.

#### Perform Print Head Cleaning as necessary

If there are gaps in the nozzle check pattern, or if there are streaks in the print results, the colors are wrong, or there are ink drops, perform Print Head Cleaning.

When Print Head Cleaning is complete, print the nozzle check pattern again to check the condition of the nozzles.

See the following for details on how to perform Print Head Cleaning.

[“Performing Print Head Cleaning” on page 96](#)

#### Perform Print Head Cleaning periodically

This printer comes with a built-in automatic maintenance function that automatically performs Print Head Cleaning periodically (approximately once every three hours) or when it is determined to be necessary based on the results of automatically monitoring the nozzles.

You can change the Print Head Cleaning frequency for the automatic maintenance function to a shorter period of time when necessary, for example, if you are using media that scuffs easily.

[“Media Management items” on page 114](#)

## Performing Print Head Cleaning

### Cleaning levels and order of execution

There are three levels of cleaning available: **Cleaning (Light)**, **Cleaning (Medium)**, and **Cleaning (Heavy)**.

Perform **Cleaning (Light)** first.

If you print a nozzle check pattern (Standard) after cleaning and the nozzles are still clogged, perform **Cleaning (Medium)**.

Print the **Standard** nozzle check pattern again; if the nozzles are still clogged, perform **Cleaning (Heavy)**.

### Procedure

- 1 Check that the printer is ready to print, and then press  (Menu) - **Maintenance** - **Print Head Cleaning**.
- 2 Select the cleaning level.  
First, select **Cleaning (Light)**, and then proceed to step 5.  
Next, select **Cleaning (Medium)**.  
And finally, select **Cleaning (Heavy)**.
- 3 Select the row of nozzles you want to clean.  
**All Nozzles**  
Select this option if all patterns in the printed nozzle check results (Standard) contain faint or missing segments. After making your selections, proceed to Step 5.  
**Select Nozzles**  
Select this if there are faint or missing segments in only some of the numbered patterns (nozzle arrays) in the nozzle check pattern (Standard). You can select multiple nozzle arrays.
- 4 Select the row of nozzles you want to clean, and then press **OK**.
- 5 Cleaning starts.  
A confirmation message is displayed when cleaning is complete.



## Maintenance

**6** Press **Yes** to print a nozzle check pattern and check for clogged nozzles.

Select **Center** or **Left** in **Print Position** to print in a side margin where a nozzle check pattern has already been printed. Available items change depending on the width of the loaded media.

Press **No** to close the settings menu.

### If nozzles are still clogged even after performing Cleaning (Heavy)

The areas around the print head may be soiled.

Check the following, and then perform regular cleaning.

 [“Performing Regular Cleaning” on page 77](#)

Clogged nozzles may not be cleared when you check using a nozzle check pattern (Standard) even after performing regular cleaning.

This printer has a built-in "clogged nozzle compensation function" that prints using other nozzles to compensate for ink that is not ejected due to clogged nozzles. So even if the nozzles are clogged, it may not have much effect on the print results.

You can check the print condition of the compensation function by using the nozzle check pattern (Quality Check).

#### Example when compensation function is enabled



If there is no unevenness or banding in the nozzle check pattern, you can use it as it is.

#### Example when compensation function is not enough



When there is a large number of clogged nozzles, the nozzle check pattern may contain unevenness or banding.

Contact your dealer or Epson Support for assistance.

## Long-term Storage (Pre-storage Maintenance)

### Pre-storage Maintenance Timing

Always perform pre-storage maintenance if the printer will not be used (and will be turned off) for more than two weeks.

If you do not print for a long time and do not perform pre-storage maintenance, turn the printer on at least once a week.

#### **Important:**

*If you do not perform Pre-storage Maintenance, a print head nozzle could become permanently clogged.*

For pre-storage maintenance, use the number of the cleaning ink supply units (sold separately) shown for each model in the following table.

SC-R5000 Series: x7

SC-R5000L Series: x14

### Performing Pre-storage Maintenance

#### **Important:**

*If the amount of remaining ink or cleaning fluid is insufficient, the function may not run. If there is an insufficient amount of ink remaining, have new ink supply units on hand as a precaution.*

## Maintenance

- 1 Check that the printer is ready to print, and then press  (Menu) - **Maintenance - Keeping Preparation.**
- 2 Press **Start**.
- 3 Next, follow the on-screen instructions to replace the ink supply unit.

Before storing them, clean off any ink stuck to the ink supply ports of the ink supply units that you removed.

You do not need to clean the ink supply unit for OP.

### Cleaning method

Lightly touch the corner of a cleaning stick from the supplied Cleaning Kit to the hole of the ink supply port to adsorb the ink, as shown in the illustration below. You do not need to wipe off the ink.

Use a new cleaning stick for each color to avoid mixing the colors. Do not forcefully press or move the cleaning stick.

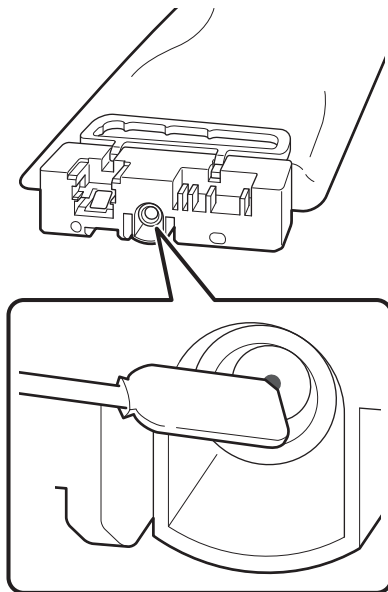

Observe the following cautions when storing the printer and ink supply units that were removed during use.

 [“Notes when not using the printer” on page 27](#)

 [“Notes on handling the ink supply units” on page 27](#)

## Restarting use of the printer

### **Important:**

*When restarting use of the printer, charge the printer with ink. When charging with removed ink supply units, have new ink supply units on hand as a precaution.*

Switch on the power and follow the on-screen instructions.

When printing for the first time after restarting, perform a Print Head Nozzle Check and check that there are no clogged nozzles.

 [“How to Print a Nozzle Check Pattern” on page 95](#)

## Cleaning the inside surface of the printer cover

Ink mist causes the inside of the printer cover to become dirty. If you continue to use the printer while this is dirty, you cannot see inside the printer.

If it is dirty, follow the steps below to clean.

- 1 Make sure the printer is turned off and the screen has turned off, and then unplug the power cable from the outlet.  
Disconnect both of the power cables.
- 2 Leave the printer for a minute.
- 3 Open the printer cover.

## Maintenance

- 4 Wipe off lint and dust that has adhered to the inside of the printer cover using a soft cloth that has been soaked in water and thoroughly wrung out.

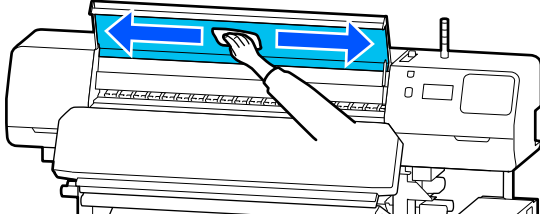

For anything that cannot be removed with a damp cloth, dip a cloth in neutral detergent, squeeze it out, and then wipe the stubborn stain.

## Cleaning pressure rollers

If you keep using the pressure rollers when they are soiled with ink mist, the print outs will be soiled.

If the rollers are dirty, follow the steps below to clean them.

- 1 Make sure the printer is turned off and the screen has turned off, and then unplug the power cable from the outlet.  
Disconnect both of the power cables.
- 2 Leave the printer for a minute.
- 3 Open the printer cover.
- 4 Raise the media loading lever.
- 5 Wrap a soft cloth that has been soaked in water and squeezed well around the tip of your finger as shown in the illustration.

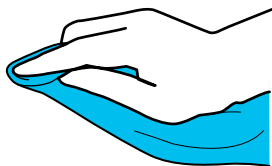

- 6 Use the cloth to wipe the sides of the pressure rollers that have become soiled.

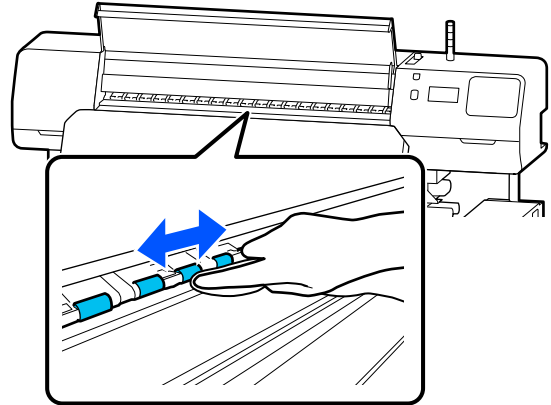

# Control Panel Menu

## Menu List

The following items and parameters can be set and executed in the Menu. See the reference pages for more details on each item.

### General Settings

For more information on these items, see [☞ “General Settings menu” on page 106](#)

Item	Parameter
Basic Settings	
LCD Brightness	1 to 9
Sounds	
Button Press	0, 1, 2, 3
Alert	0, 1, 2, 3
Completion Notice	0, 1, 2, 3
Warning Notice	
Volume	0, 1, 2, 3
Repeat	Off, Until Stopped
Error Tone	
Volume	0, 1, 2, 3
Repeat	Off, Until Stopped
Sound Type	Pattern1, Pattern2
Sleep Timer	1 to 240

## Control Panel Menu

Item	Parameter
Date/Time Settings	
Date/Time	
Time Difference	-12:45 to +13:45
Language	Japanese, English, French, Italian, German, Portuguese, Spanish, Dutch, Russian, Korean, Traditional Chinese, Simplified Chinese
Wall Paper	Gray, Black, White
Keyboard	QWERTY, AZERTY, QWERTZ
Unit Settings	
Length Unit	m, ft/in
Temperature	°C, °F
Printer Settings	
Margins	
Side Margin(Right)	3 to 25 mm (0.12 to 0.98 inches)
Side Margin(Left)	3 to 25 mm (0.12 to 0.98 inches)
Margin Between Pages	0 to 999 mm (0.00 to 39.33 inches)
Width Adjustment	-10.0 to 10.0 mm (-0.394 to 0.394 inches)
Print Start Position	0 to 1000 mm (0.00 to 39.37 inches)
Job Connection	On, Off
Media Detection	
Width Detection	On, Off
Media Width	300 to 1625.6 mm (11.81 to 64.00 inches)
End Detection	On, Off
Detect Paper Skew	On, Off
Nozzle Check between Pages	
On	
Print Page	Each 1 to 9999 pages
Off	
Information Printing at Media Cut	
Paper Remaining Information	On, Off
Heater Off Timer	0 to 30 minutes
Inside Light	Auto, Manual
Restore Default Settings	Network Settings, Clear All Data and Settings

### Control Panel Menu

Item	Parameter
Network Settings	
Network Status	Wired LAN Status, Print Status Sheet
Advanced	
Device Name	
TCP/IP	Auto, Manual
Proxy Server	Do Not Use, Use
IPv6 Address	Enable, Disable
Link Speed & Duplex	Auto, 100BASE-TX Auto, 10BASE-T Half Duplex, 10BASE-T Full Duplex, 100BASE-TX Half Duplex, 100BASE-TX Full Duplex
Redirect HTTP to HTTPS	Enable, Disable
Disable IPsec/IP Filtering	
Disable IEEE802.1X	

### Media Settings

For more information on these items, see  [“Media Settings menu” on page 112](#)

Item	Parameter
Current Settings	
Media	01 XXXXXXXXXXXX to 50 XXXXXXXXXXXX
Media Type	
Media Width	
Pass Mode	
Advanced Settings	
Print Adjustments	
Automatic Adjustment	
Manual Adjustment	
Media Feed Adjustment	Manual (Standard), Manual (Measurement)
Print Head Alignment	
Media Management	

**Control Panel Menu**

Item	Parameter
01 XXXXXXXXXXXX to 50 XXXXXXXXXXXX	
Change Name	
Media Type	Adhesive Vinyl, Banner, Non-woven Wallpaper, Film, Textile, Paper/Other
Pass Mode	1 pass, 4 pass, 5 pass, 6 pass, 9 pass, 14 pass, 20 pass, 26 pass, 35 pass
Advanced Settings	
Heater Temperature Settings	
1 pass	
Pre-heater	
Pre-heater	On, Off
Temperature	30 to 55°C (86 to 131 °F)
Platen Heater	
Platen Heater	On, Off
Temperature	30 to 50°C (86 to 122 °F)
Curing heater	
Curing heater	On, Off
Temperature	40 to 110°C (104 to 230 °F)
4 pass	This has the same settings as <b>1 pass</b> .
5 pass	
6 pass	
9 pass	
14 pass	
20 pass	
26 pass	
35 pass	
Curing Pre-Heater Temperature	0%, 20%, 40%, 60%, 80%, 100%
Drying Action	Auto, Follow Drying Time Setting
Drying Time	0 to 1200 Secs.

### Control Panel Menu

Item	Parameter
Media Back Feed after Curing	Half Way, Complete, Off
Heater Warm Up Additional Time	0 to 10 minutes
Print Head Warm Up	On, Off
Platen Gap	1.7, 2.0, 2.5
Feeding Tension	Lv1 to Lv4
Paper Suction	Lv0 to Lv10
Media Feed Speed Limitation	On, Off
Pressure Roller Load	Weak, Medium, Strong
Skew Reduction	On, Off
Roll Winding Direction	Printable Side Out, Printable Side In
Stick Prevention	On, Off
Skip Wrinkled Media	Off, 10 to 1000 mm
Periodic Cleaning	30 to 180 minutes
Print Quality Adjustment Temperature	40 to 110 °C (104 to 230 °F)
Remaining Amount Management	
Remaining Amount Management	On, Off
Remaining Amount	1.0 to 999.9 m (3.3 to 3280.5 feet)
Remaining Alert	1.0 to 15.0 m (3.3 to 49.2 feet)

### Maintenance

For more information on these items, see  [“Maintenance menu” on page 118](#)

Item	Parameter
Print Head Nozzle Check	
Print Position	Right, Center, Left
Nozzle Check Pattern	Standard, Quality Check
Print Head Cleaning	
Cleaning(Light)	All Nozzles
Cleaning(Medium)	Select Nozzles, All Nozzles
Cleaning(Heavy)	
Cleaning the Maintenance Parts	Anti-Drying Caps, Around the Head, Suction Cap, Flushing Pad, Media Cleaner
Replace Waste Ink Bottle	



### Control Panel Menu

Item	Parameter
Replace Wiper Unit	
Keeping Preparation	Start

#### Supply Status

Details on menu [☞](#) [“Supply Status menu” on page 119](#)

#### Replacement Part Information

Details on menu [☞](#) [“Replacement Part Information menu” on page 119](#)

#### Printer Status/Print

Details on menu [☞](#) [“Printer Status/Print menu” on page 120](#)

Item	Parameter
Firmware Version	
Printer Name	
Fatal Error Log	
Operation Report	Total Print Area, Total Media Feed Length, Total Carriage Pass

## Control Panel Menu

## Details of the Menu

### General Settings menu

\* indicates default settings.

Item	Parameter	Explanation
Basic Settings		
LCD Brightness	1 to 9 (9*)	Adjusts the brightness of the control panel display.
Sounds		
Button Press	0	Sets the volume of the sounds when the power button and control panel screen are operated.
	1*	
	2	
	3	
Alert	0	Sets the volume of the sounds when hardware, such as the covers and media loading lever, are operated.
	1	
	2*	
	3	
Completion Notice	0	Sets the volume of the sounds when print jobs or maintenance operations are finished.
	1	
	2	
	3*	
Warning Notice		
Volume	0	Sets the volume and the repetitions of sounds when it is time to replace consumables.
	1	
	2*	
	3	
Repeat	Off*	
	Until Stopped	





## Control Panel Menu

Item	Parameter	Explanation
Error Tone		
Volume	0	Sets the volume and the repetitions of sounds when an error occurs and printing cannot continue.
	1	
	2	
	3*	
Repeat	Off	
	Until Stopped*	
Sound Type	Pattern1*	Sets the type of sounds. Sounds that are easy to hear in the printer's operating environment can be set.
	Pattern2	
Sleep Timer	1 to 240 (15*)	<p>Set how long before the printer enters sleep mode when no print jobs are received and no errors are detected. In sleep mode, heaters turn off, the control panel turns off, and the internal motors and other components consume less power.</p> <p>To reactivate the control panel display, press any button in the control panel except . The control panel display will however turn off again if no operations are performed for another 30 seconds under these conditions. The printer and heaters are only fully reactivated when a print job is received, the media loading lever is used, or another operation involving printer hardware is performed.</p>
Date/Time Settings		
Date/Time		Set the printer's built-in clock. The time set here is displayed on the Home screen. It is also used for job logs and the printer's status as shown in Epson Edge Dashboard.
Time Difference	-12:45 to +13:45	Set the time difference with coordinated universal time (UTC) in 15 minute increments. In network environments with a time difference, set this as necessary when administrating the printer.

**Control Panel Menu**

Item	Parameter	Explanation
Language	Japanese	Select the language used in the control panel display.
	English*	
	French	
	Italian	
	German	
	Portuguese	
	Spanish	
	Dutch	
	Russian	
	Korean	
	Traditional Chinese	
Simplified Chinese		
Wall Paper	Gray	Select the color scheme used in the control panel display. You can set a color scheme that is easy to see in the environment in which the printer is installed.
	Black*	
	White	
Keyboard	QWERTY*	Select the keyboard layout for the text input screen that appears, such as when inputting names to register for media settings.
	AZERTY	
	QWERTZ	
<b>Unit Settings</b>		
Length Unit	m*	Choose the units of length used in the control panel display and when printing test patterns.
	ft/in	
Temperature	°C*	Choose the temperature units used in the control panel display.
	°F	
<b>Printer Settings</b>		



## Control Panel Menu

Item	Parameter	Explanation
Margins		
Side Margin(Right)	3 to 25 mm (5*) (0.12 to 0.98 inches [0.20*])	Choose the width of the right margin when media is loaded in the printer. See the following for more information.  <a href="#">"Printable area" on page 70</a>
Side Margin(Left)	3 to 25 mm (5*) (0.12 to 0.98 inches [0.20*])	Choose the width of the left margin when media is loaded in the printer. See the following for more information.  <a href="#">"Printable area" on page 70</a>
Margin Between Pages	0 to 999 mm (10*) (0.00 to 39.33 inches [0.39*])	Sets the margin between printed pages. For single-page print jobs, this is the margin placed between jobs.
Width Adjustment	-10 to +10 mm (0*) (-0.394 to 0.394 inches [0.00*])	You can adjust a margin between pages. Even after making adjustments, the size of the margin may change, depending on the media and usage environment.  The margin increases when the number is moved in the + direction, and decreases when the number is moved in the - direction.   <a href="#">"Printable area" on page 70</a>
Print Start Position	0 to 1000 mm (0*) (0.00 to 39.37 inches [0.00*])	Adjust this parameter if you want to print from the near center of the media or if you want to shift the printed area left from the <b>Side Margin (Right)</b> setting. The area from the right edge of the media, is left blank using the width set in <b>Print Start Position</b> . If a value is selected for <b>Side (Right)</b> , an additional area corresponding to the width selected for <b>Side (Right)</b> will be left blank. See the following for more information.   <a href="#">"Printable area" on page 70</a>

**Control Panel Menu**

Item	Parameter	Explanation
Job Connection	On*	When this is set to <b>On</b> , the next job starts printing without performing operations, such as feeding media through the curing heater or rewinding the media after curing, between continuous print jobs. There are no operations between jobs so printing time is that much shorter. Continuous print jobs are a series of jobs in which the print job data is sent from the computer to the printer as soon as the previous print job data has been sent from the computer and received by the printer. If the pass mode is different between the previous print job and the next print job, the jobs are not connected.
	Off	
Media Detection		
Width Detection	On*	Select whether the media width is detected ( <b>On</b> ) or not ( <b>Off</b> ). Try setting <b>Off</b> when printing if media width errors are displayed even though the media is correctly loaded. However, we recommend setting this to <b>On</b> when using the printer. Changed settings are reflected when the media is reloaded.
	Off	
Media Width	300 to 1625.6 mm (300*) (11.81 to 64.00 inches [11.81*])	When <b>Width Detection</b> is <b>Off</b> , the value of the media width must be set correctly according to the width of the media loaded in this setting. If the correct media width is not set, the printer may print beyond the edges of the media. Ink used outside the edges of the media will stain the inside of the printer.
End Detection	On*	Select whether or not ( <b>On/Off</b> ) the end of the media is detected. Try setting <b>Off</b> when printing if media out errors are displayed even though the media is correctly loaded. We recommend this normally be set to <b>On</b> when using the printer.
	Off	
Detect Paper Skew	On	Select whether the printer will stop printing and display an error ( <b>On</b> ) or whether the printer will continue printing ( <b>Off</b> ) when skewed media is detected. <b>On</b> is recommended in most circumstances, as skewed media may cause the printer to jam.
	Off*	
Nozzle Check between Pages		
On		When <b>On</b> is set, a nozzle check pattern is printed periodically at the specified timing. When printing is complete, you can visually inspect the check pattern to determine whether there are any stripes or unevenness in the preceding or following printout.  <b>Print Page</b> sets the timing at which check patterns are printed.
Print Page	Each 1 to 9999 pages	
Off*		

### Control Panel Menu

Item	Parameter	Explanation
Information Printing at Media Cut		
Paper Remaining Information	On	<p>When this is set to <b>On</b>, the following information is printed when you press  on the control panel screen to feed the media to the cutting position. When <b>Remaining Amount Management</b> is set to <b>On</b>, the remaining length of the media is also printed. You can print the length of the unprinted media on the media that you will remove, and then the next time you load this media, you can enter the printed length in the Remaining Amount Management setting for accurate management of the amount of media remaining.</p> <ul style="list-style-type: none"> <li><input type="checkbox"/> Model name: Model of the printer</li> <li><input type="checkbox"/> Serial number: Serial number of the printer</li> <li><input type="checkbox"/> Date and time: Date and time of printing</li> <li><input type="checkbox"/> Bank number: Registered media number selected when printing</li> <li><input type="checkbox"/> Media type: Media Type of the registered media selected when printing</li> <li><input type="checkbox"/> Media width: Automatically detected value of media width</li> </ul>
	Off*	
Heater Off Timer	0 to 30 (0*)	<p>You can set how long the printer should continue to pre-heat when no print jobs have been received before canceling pre-heat and turning off all of the heaters. Depending on the media, if the transition time is too long, the heat may cause damage such as deformation. Check the status of the media to make the appropriate settings.</p> <p>Each heater starts heating when a print job is received; however, if you want to pre-heat them in advance, press <b>Preheat Start</b> on the Home screen.</p>
Inside Light	Auto*	<p>Select whether to turn on/off the light inside the printer cover automatically (<b>Auto</b>) or whether to use the control panel operations as necessary (<b>Manual</b>).</p> <p>In <b>Auto</b>, the light turns on automatically when printing and so on, and turns off when the operation is complete.</p> <p>In <b>Manual</b>, you need to press  on the control panel screen to turn the light on/off.</p> <p>When you press  during an operation that does not allow the light to turn on, the light turns on as soon as possible.</p>
	Manual	
Restore Default Settings	Network Settings	Executing <b>Network Settings</b> restores all the items for <b>Advanced</b> in the network settings menu to their default setting values.
	Clear All Data and Settings	Executing <b>Clear All Data and Settings</b> restores all settings to their default setting values.
Network Settings		

### Control Panel Menu

Item	Parameter	Explanation
Network Status	Wired LAN Status	You can check batches of a variety of information in network settings that are set in <b>Advanced</b> . When <b>Print Status Sheet</b> is selected, a list is printed.
	Print Status Sheet	
Advanced		
Device Name		Do a variety of network settings.
TCP/IP	Auto	
	Manual	
Proxy Server	Do Not Use	
	Use	
IPv6 Address	Enable*	
	Disable	
Link Speed & Duplex	Auto*	
	100BASE-TX Auto	
	10BASE-T Half Duplex	
	10BASE-T Full Duplex	
	100BASE-TX Half Duplex	
	100BASE-TX Full Duplex	
Redirect HTTP to HTTPS	Enable*	
	Disable	
Disable IPsec/IP Filtering		Use the pe-installed software Web Config to enable this setting.
Disable IEEE802.1X		You can only disable the setting from here. See the following for detailed information on starting Web Config.  <a href="#">"Using Web Config" on page 44</a>

## Media Settings menu

\* indicates default settings.

Item	Parameter	Explanation
Current Settings		



### Control Panel Menu

Item	Parameter	Explanation
Media	01 XXXXXXXXXXXX to 50 XXXXXXXXXXXX	Choose the media settings to use. The registered name appears in XXXXXXXXXXXX.
Media Type		Displays the currently selected Media Type. This cannot be changed.
Media Width		Set the <b>Media Detection</b> items.
Pass Mode		Displays the currently selected Pass Mode. This can be changed.
Advanced Settings		You can change the <b>Advanced Settings</b> for the registered media selected in <b>Media</b> . See the following table for details on the setting content. <a href="#">🔗 "Media Management items" on page 114</a>
Print Adjustments		
Automatic Adjustment		Perform <b>Automatic Adjustment</b> in the following cases.
Manual Adjustment		<input type="checkbox"/> When registering media settings in the EMX file to the printer <input type="checkbox"/> When changing <b>Advanced Settings</b> after saving media settings <input type="checkbox"/> When the media type is the same but the width is different
Media Feed Adjustment	Manual (Standard) Manual (Measurement)	If an error occurs when you perform Automatic Adjustment, or if you notice banding or graininess in the print results, perform <b>Manual Adjustment</b> .
Print Head Alignment		See the following for more information. <a href="#">🔗 "Optimizing Media Settings (Automatic Adjustment)" on page 61</a>
Media Management		
	01 XXXXXXXXXXXX to 50 XXXXXXXXXXXX	<a href="#">🔗 "Media Management items" on page 114</a>
Remaining Amount Management		
Remaining Amount Management	On Off*	When <b>On</b> is selected, you can set <b>Remaining Amount</b> and <b>Remaining Alert</b> . Setting each item to manage the remaining amount makes it easier to know when it is time to replace the media. When this is set to <b>On</b> , once you have loaded the media and selected the registered media settings number, you will be prompted to enter the media length (Remaining Amount).
Remaining Amount	1.0 to 999.9 m (50.0 m*) (3.3 to 3280.5 feet [164.0*])	Set the total length of the loaded media. You can set in 0.1 m increments. The amount of media remaining is estimated based on the length you set here and the length of the printout, and is displayed on the Home screen.
Remaining Alert	1.0 to 15.0 m (5 m*) (3.3 to 49.2 feet [16.4*])	Set a value at which point a warning message is displayed to inform you that the remaining amount of media is too low. You can set in 1 m increments. Depending on settings such as <b>Media Back Feed after Curing</b> , a media end error may occur when the remaining amount of media is below approximately 1.6 m.

## Control Panel Menu

### Media Management items

When you download an EMX file using the supplied Epson Edge Print or Epson Edge Dashboard and register the media setting values to the printer, the media setting values are already set to match the media being used and therefore do not need to be changed. When using special media or when a problem such as head striking or banding is detected in printing results, change the default.

The default settings for each of the following items differ depending on the content set in **Media Type**.

Item	Parameter	Explanation
Change Name		Assign a name of up to 20 characters to the media settings being saved. Using distinctive names makes it easier to select banks for use.
Media Type	Adhesive Vinyl	Select the Media Type according to the loaded media.
	Banner	The printer stores general media settings according to the Media Type. When the Media Type is changed, each media setting value registered to the current registered media number changes to the value for the Media Type after changing.
	Non-woven Wallpaper	
	Film	
	Textile	
	Paper/Other	
Pass Mode	1 pass	Normally, printing is performed according to the print pass settings included in the print job. If the print job does not include the number of print passes, printing is performed according to this setting.
	4 pass	
	5 pass	
	6 pass	
	9 pass	
	14 pass	
	20 pass	
	26 pass	
	35 pass	
Advanced Settings		

**Control Panel Menu**

Item	Parameter	Explanation
Heater Temperature Settings		
1 pass		
Pre-heater		
Pre-heater	On	Select whether or not ( <b>On/Off</b> ) to use the pre-heater. When this is set to <b>Off</b> , the heater does not heat up even when a print job is received or when you press <b>Preheat Start</b> on the Home screen/Startup adjustment screen.
	Off	
Temperature	30 to 55°C (86 to 131 °F)	The heater heats up to the temperature set here when a print job is received or when you press <b>Preheat Start</b> on the Home screen/Startup adjustment screen.
Platen Heater		
Platen Heater	On	Select whether or not ( <b>On/Off</b> ) to use the platen heater. When this is set to <b>Off</b> , the heater does not heat up even when a print job is received or when you press <b>Preheat Start</b> on the Home screen/Startup adjustment screen.
	Off	
Temperature	30 to 50°C (86 to 122 °F)	The heater heats up to the temperature set here when a print job is received or when you press <b>Preheat Start</b> on the Home screen/Startup adjustment screen. If the temperature of the platen heater is raised too high, the nozzles may become clogged.
Curing heater		
Curing heater	On	Select whether or not ( <b>On/Off</b> ) to use the curing heater. When this is set to <b>Off</b> , the heater does not heat up even when a print job is received or when you press <b>Preheat Start</b> on the Home screen/Startup adjustment screen.
	Off	
Temperature	40 to 110°C (104 to 230 °F)	The heater heats up to the temperature set here when a print job is received.
4 pass	This has the same settings as <b>1 pass</b> .	
5 pass		
6 pass		
9 pass		
14 pass		
20 pass		
26 pass		
35 pass		

## Control Panel Menu

Item	Parameter	Explanation
Curing Pre-Heater Temperature	0%	Set the pre-heat temperature for the curing heater when you press <b>Preheat Start</b> on the Home screen or the Startup adjustment screen. Set this as a percentage (%) of the curing heater temperature you set.
	20%	
	40%	
	60%	
	80%	
	100%	
Drying Action	Auto	When this is set to <b>Auto</b> , printing is performed up to the width of the loaded media without drying between passes. The print head moves up to 54 inches even when the media width is less than 54 inches.
	Follow Drying Time Setting	When you select <b>Follow Drying Time Setting</b> , the time set in <b>Drying Time</b> is added to the manufacturer's drying time.
Drying Time	0 to 1200 Secs.	Set this when you want to extend the movement time beyond the manufacturer's curing heater movement time.  If it is difficult to cure the ink due to the ink density or media, adjust the movement time by checking the print results and the condition of the media.  Increasing the drying time increases the time needed to print. Also, some media may be deformed by increasing the drying time.
Media Back Feed after Curing	Half Way	Sets at which point in the curing operation to rewind the media to the print start position for the next job. Set this according to the characteristics of the media being used.  When this is set to <b>Off</b> , the end of the print is fed to the base of the curing heater without rewinding, leaving a margin of approximately 670 mm to the leading edge of the next job. This setting is suitable when using media that is affected by heat.  When <b>Half Way</b> is set, when the end of the print passes the center of the curing heater, the media is rewound until the end of the print is positioned on the platen. Approximately 150 mm of unprinted media is heated in the curing heater, and the next job is printed on the heated media. This setting is suitable when using media that is not easily affected by heat.  When <b>Complete</b> is set, when the end of the print is fed to the base of the curing heater, the media is rewound until the end of the print is positioned on the platen. Approximately 410 mm of unprinted media is heated in the curing heater, and the next job is printed on the heated media. This setting is suitable when using media that is not easily affected by heat.
	Complete	
	Off	

## Control Panel Menu

Item	Parameter	Explanation
Heater Warm Up Additional Time	0 to 10 minutes	Set a longer time if you are concerned that the scratch resistance of the print start area is poor.  We recommend setting a longer time, especially if you are using thick media.
Print Head Warm Up	On	Set this to <b>On</b> if the colors of the adjacent prints do not match when using tiling, or if the colors do not match immediately after printing starts when printing long jobs.  When you select <b>On</b> , the print head is warmed up before printing starts to prevent color differences. As a result, it may take longer to start printing.
	Off	
Platen Gap	1.7	Set the Platen Gap (the distance between the print head and the media).  In most situations, use the values set for each media type as they are. If the print results are scratched or smudged, they may be improved by setting a larger value. However, choosing a larger gap than required may result in ink stains inside the printer, reduced print quality, or shorter product life.
	2.0	
	2.5	
Feeding Tension	Lv1 to Lv4	In most situations, use the values set for each Media Type as they are. Increase tension if creases appear in the media during printing. The higher the value, the greater the tension.
Paper Suction	Lv0 to Lv10	Set the strength of the suction by the platen on the media. The higher the value, the greater the suction.  In most situations, use the values set for each Media Type as they are. If the media is wavy on the platen, increase the set value.  If graininess or out-of-focus characteristics are detected in printing results obtained using thin or soft media or if the media is not fed normally, reduce the set value.
Media Feed Speed Limitation	On	Normally, leave this <b>Off</b> .  Set this to <b>On</b> if media sticks, wrinkles, or tears easily when printing on thin media.  When this is set to <b>On</b> , print speed slows down.
	Off	
Pressure Roller Load	Weak	In most situations, use the values set for each Media Type as they are. If the following occurs when printing, you may be able to avoid it by reducing the Pressure Roller Load (for example: <b>Medium</b> → <b>Weak</b> )  <input type="checkbox"/> Wrinkling around the pressure rollers. <input type="checkbox"/> Staining due to the media striking the print head. <input type="checkbox"/> Pressure rollers leaving marks on the media.
	Medium	
	Strong	









### Control Panel Menu

Item	Parameter	Explanation
Skew Reduction	On	Select whether or not ( <b>On/Off</b> ) the printer performs operations to correct media skew (media fed skewed) when media is loaded. Normally, leave this <b>On</b> . Set this to <b>Off</b> if the media shows marks from the pressure rollers due to skew corrections.
	Off	
Roll Winding Direction	Printable Side Out	Set this according to the winding specifications of the media being loaded.
	Printable Side In	
Stick Prevention	On	Select whether to do non-stick operations ( <b>On</b> ) or not ( <b>Off</b> ) when the printer is turned on, or when printing begins, etc.
	Off	Normally, leave this <b>Off</b> . Depending on the type of media, such as ultra-thin media, some may stick more easily to the platen. Starting operations with media stuck to the platen may cause the media to not feed correctly and result in a paper jam. Set <b>On</b> if this happens. Operating time takes longer when <b>On</b> is set.
Skip Wrinkled Media	Off	Normally, leave this <b>Off</b> .
	10 to 1000 mm	To avoid wrinkles at the start of printing, we recommend setting the length to 500 mm. However, if you want to set a different length depending on the media you are using and the print content, you can set the length so that printing is not performed within a range of 10 to 1000 mm from the leading edge. Set the length in increments of 10 mm. However, no media is fed when jobs are continuous.
Periodic Cleaning	30 to 180 minutes	To keep the printer in optimum condition, it is automatically maintained by performing Print Head Cleaning every three hours.
		Depending on how much the printer is used, you may want to set the frequency at which periodic Print Head Cleaning is performed to shorter intervals than automatic maintenance.
Print Quality Adjustment Temperature	40 to 110 °C (104 to 230 °F)	Set the temperature to perform <b>Manual Adjustment (Measurement)</b> from <b>Media Feed Adjustment</b> in <b>Print Adjustments</b> . <b>Manual Adjustment (Measurement)</b> is not performed unless the temperature of the curing heater reaches the temperature you set here.

### Maintenance menu

Item	Parameter	Explanation
Print Head Nozzle Check		
Print Position	Right	Print a <b>Standard</b> pattern, and then check the status of the nozzles for the print head. Inspect the pattern visually and perform <b>Print Head Cleaning</b> if you detect any missing colors.  See the following for details.   <a href="#">"How to Print a Nozzle Check Pattern" on page 95</a>
	Center	
	Left	
Nozzle Check Pattern	Standard	
	Quality Check	
Print Head Cleaning		

## Control Panel Menu

Item	Parameter	Explanation
Cleaning(Light)	All Nozzles	<p>You can set cleaning from three levels. Perform <b>Cleaning (Light)</b> first. If clogging is not cleared by performing <b>Cleaning (Light)</b>, perform <b>Cleaning (Medium)</b>, and then <b>Cleaning (Heavy)</b> if necessary.</p> <p>When you select <b>Cleaning (Medium)</b> or <b>Cleaning (Heavy)</b>, note the numbers of patterns in the <b>Standard</b> pattern that contain faint or missing dots, and then select and clean all the rows of nozzles or the rows of nozzles including those numbers.</p> <p> <a href="#">"Print Head Cleaning" on page 96</a></p>
Cleaning(Medium)	All Nozzles, Select Nozzles	
Cleaning(Heavy)		
Cleaning the Maintenance Parts	Anti-drying caps	<p>Start cleaning the selected parts. See the following for detailed information on cleaning the parts.</p> <p> <a href="#">"Cleaning the anti-drying caps" on page 80</a></p>
	Around the Head	 <a href="#">"Cleaning Around the Print Head" on page 79</a>
	Suction Cap	 <a href="#">"Cleaning the Suction Cap" on page 83</a>
	Flushing pad	 <a href="#">"Cleaning Around the Flushing Pad" on page 84</a>
	Media cleaner	 <a href="#">"Cleaning the Media Cleaner" on page 85</a>
Replace Waste Ink Bottle		<p>If you are replacing the waste ink bottle before the message indicating that it is time to replace the waste ink bottle appears on the control panel's screen, do so from this menu.</p>
Replace Wiper Unit		<p>Starts the wiper unit replacement procedure. See the following for detailed information on replacing the parts.</p> <p> <a href="#">"Replacing the Wiper Unit" on page 91</a></p>
Keeping Preparation		<p>Always run this procedure if the printer will not be used for two weeks or more (and will be turned off at this time.)</p> <p>See the following for more information.</p> <p> <a href="#">"Long-term Storage (Pre-storage Maintenance)" on page 97</a></p>

## Supply Status menu

Displays the amount of wear and the model number for each consumable item.

If you are using the SC-R5000L Series, select **Ink** to perform the following checks and settings.

- Check which ink supply unit is currently operating or supplying ink
- Check the status of non-operational ink supply units
- Manually switch the operational ink supply unit

## Replacement Part Information menu

Displays the replacement timing for the selected replacement part.

Contact your dealer or Epson Support for assistance.

## Control Panel Menu

---

**Printer Status/Print menu**

Item	Parameter	Explanation
Firmware Version		Shows and prints the selected information.  If you set the printer name using Epson Edge Dashboard supplied with this printer, that name is displayed in <b>Printer Name</b> .
Printer Name		
Fatal Error Log		
Operation Report	Total Print Area	
	Total Media Feed Length	
	Total Carriage Pass	



## Problem Solver

# Problem Solver

## When a Message is Displayed

If one of the following messages is displayed, read and follow the instructions below.

Messages	What to do
Before storage, clean the ink supply port for the removed ink supply unit. See your documentation.	<p>Before you store ink supply units that you remove during use, use a cleaning stick from the supplied Cleaning Kit to adsorb any ink stuck to their ink supply ports. Dried ink on the supply port may cause ink leaks when the ink cartridge/ink supply unit is reinserted and used.</p> <p>See the following for more information on cleaning methods.</p> <p> <a href="#">"Long-term Storage (Pre-storage Maintenance)" on page 97</a></p>
The combination of the IP address and the subnet mask is invalid. See your documentation for more details.	<p>Make sure you have entered the correct values for the IP address and the default gateway.</p> <p>If you do not know the correct values, contact your network administrator.</p>
You need to set the heater temperature for this job on the printer. Set the heater temperature to start printing.	<p>The curing heater temperature for the Pass Mode for the received print job has not been set. Press <b>Heater Temperature Settings</b> to set the temperature for the curing heater to start printing. If the temperature of the curing heater is too low, the ink will not be cured correctly and the back of the media will be stained with ink when winding. On the other hand, if the temperature is too high, it will cause the media to shrink and warp. Set an appropriate temperature.</p> <p>To change the Pass Mode in the RIP, press <b>Cancel Print</b> to stop printing.</p>

## When a Maintenance Call/Printer Error Occurs

Error messages	What to do
Maintenance Request: Replace Parts Soon XXXXXXXX	<p>A part used in the printer is nearing the end of its service life.</p> <p>Contact your dealer or Epson Support and tell them the maintenance request code.</p> <p>You cannot clear the maintenance request until the part is replaced. A printer error occurs if you continue to use the printer.</p>
Maintenance Request: End Of Parts Service Life XXXXXXXX	
Printer error. For details, see your documentation. XXXXXX	<p>Printer errors are displayed in the following situations.</p> <ul style="list-style-type: none"> <li><input type="checkbox"/> The power cable is not connected securely</li> <li><input type="checkbox"/> An error that cannot be cleared occurs</li> </ul> <p>When a printer error occurs, the printer automatically stops printing. Turn off the printer, disconnect the power cable from the outlet and from the AC inlet on the printer, and then reconnect. Turn on the printer again multiple times.</p> <p>If the same call for service is displayed on the LCD panel, contact your dealer or EpsonSupport for assistance. Tell them the call for service code is "XXXXXX".</p>

## Problem Solver

## Troubleshooting

### You cannot print (because the printer does not work)

#### The printer does not turn on.

- **Is the power cable plugged into the electrical outlet or the printer?**

Make sure the power cable is securely plugged into the printer.

- **Is there any problem with the electrical outlet?**

Make sure your outlet works by connecting the power cable for another electric product.

#### The printer is not communicating with the computer.

- **Is the cable plugged in properly?**

Make sure the printer's interface cable is securely plugged into the correct terminal of the computer and the printer. Also, make sure the cable is not broken nor bent. If you have a spare cable, try connecting with the spare cable.

- **Does the interface cable specification match the specifications for the computer?**

Make sure the interface cable specifications match the specifications for the printer and the computer.

 ["Specifications Table" on page 143](#)

- **When using a USB hub, is it being used correctly?**

In the USB specification, daisy-chains of up to five USB hubs are possible. However, we recommend that you connect the printer to the first hub connected directly to the computer. Depending on the hub you are using, the operation of the printer may become unstable. If this should occur, plug the USB cable directly into your computer's USB port.

- **Is the USB hub recognized correctly?**

Make sure the USB hub is recognized correctly on the computer. If it has, disconnect the USB hub from the computer and connect the computer directly to the printer. Ask the USB hub manufacturer about USB hub operation.

#### You cannot print under the network environment.

- **Are the network settings correct?**

Ask your network administrator for the network settings.

- **Connect the printer directly to the computer using a USB cable, and then try to print.**

If you can print via USB, there are some problems on the network environment. Ask your system administrator, or refer to the manual for your network system. If you cannot print via USB, see the appropriate section in this User's Guide.

#### The printer has an error.

- **Confirm if errors have occurred in the printer by checking the lights and messages on the printer's control panel.**

 ["Control panel" on page 16](#)

 ["When a Message is Displayed" on page 121](#)

#### The printer sounds like it is printing, but nothing prints

#### The print head moves, but nothing prints.

- **Confirm the printer operation.**

Print a test pattern. Test patterns can be printed without connecting the printer to a computer and hence can be used to check printer function and status.  ["How to Print a Nozzle Check Pattern" on page 95](#)

Refer to the following section for information on what to do if the pattern does not print correctly.

## Problem Solver

### Test pattern does not print correctly.

#### ■ Perform Print Head Cleaning.

The nozzles may be clogged. Print a test pattern again after performing Print Head Cleaning.

 ["Print Head Cleaning" on page 96](#)

#### ■ Has the printer been left unused for a long time?

If the printer has not been used for a long time, the nozzles may have dried up and have been clogged. Steps to take when the printer has not been used for a long time  ["Notes when not using the printer" on page 27](#)

### The prints are not what you expected

#### Print quality is poor, uneven, too light, too dark, obvious graininess, or the tone differs.

#### ■ Are the print head nozzles clogged?

If the nozzles are clogged, specific nozzles do not fire ink and the print quality declines. Try printing a test pattern.

 ["How to Print a Nozzle Check Pattern" on page 95](#)

#### ■ Perform Print Head Alignment.

Given that there is a slight gap between the print head and the media, the landing sites for each ink may be affected by humidity, temperature, or inertial forces imparted by the print head, as well as the direction of the print head as it moves from right to left or left to right. As a result, the printing result may show obvious graininess or out-of-focus characteristics.

Select **Print Adjustments - Print Head Alignment** in the media settings to adjust print head misalignment that occurs during printing.

 ["Print Head Alignment" on page 63](#)

#### ■ Perform Media Feed Adjustment.

Large discrepancies in the feed amount cause banding (horizontal banding, tint unevenness, or stripes). Select **Print Adjustments - Media Feed Adjustment** in the media settings to make adjustment based on the target media.

 ["Media Feed Adjustment" on page 62](#)

#### ■ Are you using a genuine Epson ink supply unit?

This printer is developed for use with genuine Epson ink supply units. If you use non-Epson ink cartridges, printouts may be faint, or the color of the printed image may be changed because the remaining ink level is not correctly detected. Be sure to use the correct ink supply unit.

#### ■ Are you using an old ink supply unit?

The print quality declines when an old ink supply unit is used. Replace the old ink supply unit with a new one. Use all of the ink in the ink supply unit before the date printed on the package or within a year of installing the ink supply unit in the ink unit, whichever is sooner.

#### ■ Are the heaters at the correct temperature?

Raise the temperature of the pre-heater/platen heater if the print results are blurred or smudged or the ink clots. Note that raising the temperature too high in the curing heater can cause the media to shrink, wrinkle, or deteriorate. If the temperature of the platen heater is raised too high, the nozzles may become clogged. When changing the temperature, make sure you set it to an appropriate temperature.

In addition, the heaters may require some time to reach the desired temperature if the ambient temperature is low. The heaters may also not have the desired effect after reaching the selected temperature if the media is too cold. Allow the media to warm to room temperature before use.

#### ■ Are media settings correct?

Confirm that the media settings in the software RIP or on the printer match the media actually in use.

#### ■ Have you compared the printing result with the image on the display monitor?

Since monitors and printers produce colors differently, printed colors will not always match on-screen colors perfectly.

## Problem Solver

### ■ Was a printer cover opened during printing?

Opening the printer cover or maintenance cover during printing causes the print head to stop abruptly, resulting in uneven colors. Do not open the covers while printing is in progress.

## The print is not positioned properly on the media.

### ■ Is the media loaded correctly and are the margins correct?

If the media is not loaded correctly, the results may be off center or part of the data may not be printed. You should also check whether the correct options are selected for **Side** and **Print Start Position** in the setup menu.

 ["Loading media" on page 47](#)

 ["General Settings menu" on page 106](#)

### ■ Is the media skewed?

If **Off** is selected for **Detect Paper Skew** in the settings menu, printing will continue when the media is skewed and data will appear outside the print area. Set **Detect Paper Skew** to **On** in the settings menu.

 ["General Settings menu" on page 106](#)

### ■ Is the media wide enough for the print data?

Although printing normally stops if the print image is wider than the media, data will be printed beyond the edges of the media if **Off** is selected for **Width Detection** in the setup menu. Choose **On** for **Width Detection** in the setup menu.

 ["General Settings menu" on page 106](#)

## Vertical ruled lines are misaligned.

### ■ Is the media wavy?

Certain types of media may develop waves under some conditions (humidity and temperature) while installed in the printer. If a wave has developed, press the  button in the control panel to feed the media and avoid the affected area. We recommend that you lower the temperature and humidity to prevent waves developing.

### ■ Is the print head misaligned?

If the print head is misaligned, ruled lines may be misaligned accordingly. When vertical ruled lines are misaligned, select **Print Adjustments - Print Head Alignment** in the media settings to adjust print head misalignment that occurs during printing.

 ["Print Head Alignment" on page 63](#)

## Media

### Media Jams.

### ■ Is media curled, folded, curved, creased, or waved?

Cut and remove the curled, folded, curved, creased, or waved part.

 ["Cutting media" on page 65](#)

### ■ Is media loaded just before printing?

The pressure rollers may crease media left in the printer, or the media may also become wavy or curled.

### ■ Is the media too thick or too thin?

Check the media specifications to determine whether it can be used in the printer.

 ["Supported Media" on page 134](#)

For information on how to configure print settings using the software RIP, contact the RIP manufacturer.

## Printing does not stop when the roll ends.

### ■ Is the item for having the printer detect the end of the media set to Off?

When **End Detection** is set to **Off** from the Printer Settings menu, the end of the media is not detected.

 ["General Settings menu" on page 106](#)

## Removing Jammed Media.

If an error is displayed, follow the steps below to remove jammed media.

**Problem Solver**

**⚠ Caution:**

*Be careful not to trap your hands or fingers when opening or closing the printer cover. Failure to observe this precaution could result in injury.*

- 1** Open the printer cover.

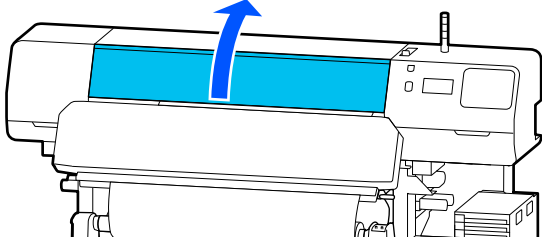

- 2** While holding both tabs on the media edge plates, move them to the right and left sides of the platen.

**⚠ Important:**

*Stop using the printer if the media edge plates are deformed. Continuing to use the printer while the media edge plates are deformed could damage the pressure rollers or print head.*

*Contact your dealer or Epson Support.*

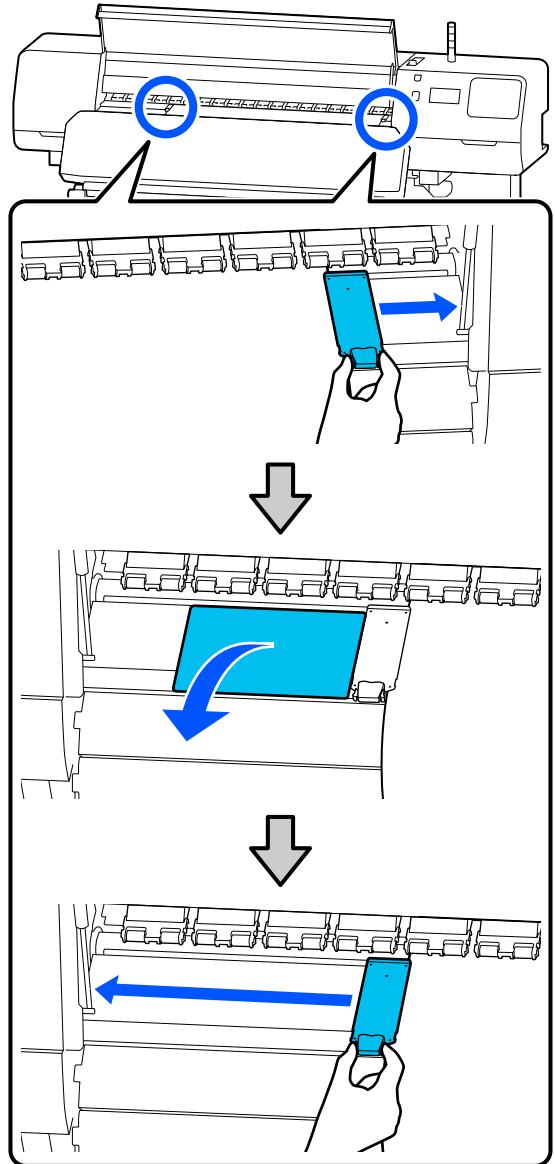

- 3** If the print head is over the media, move it away from the jam.

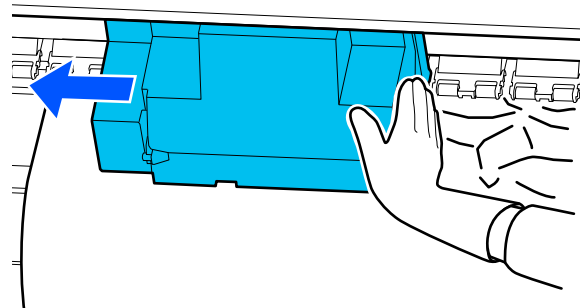

**Problem Solver**

**! Important:**

*Move the print head only after moving the media edge plates and the thermal sheet out of the way. Contact with deformed media edge plates could damage the print head.*

**4** Flip the media loading lever backwards.

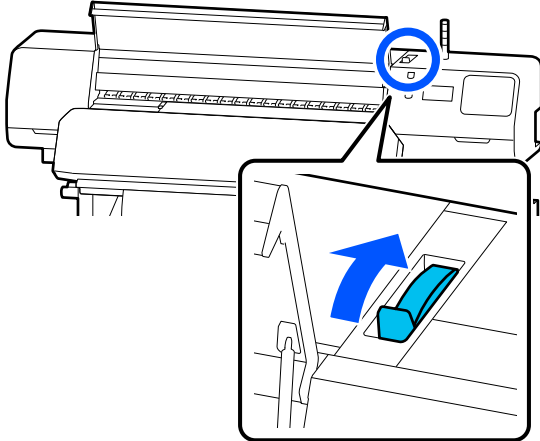

**5** When using the Auto Take-up Reel Unit, raise the tension bar.

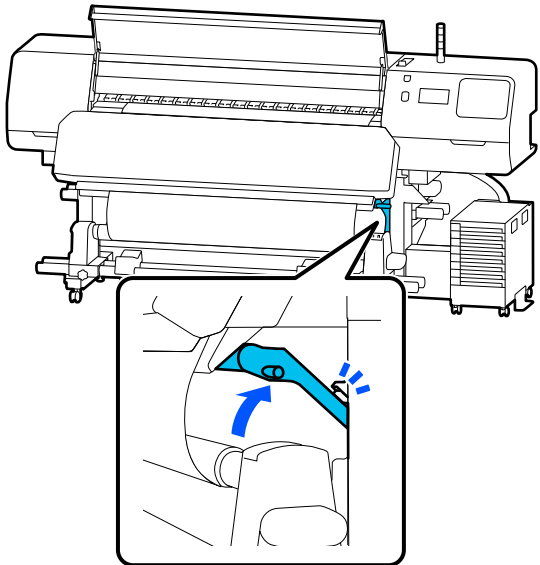

**6** Use scissors to cut away any torn or wrinkled parts.

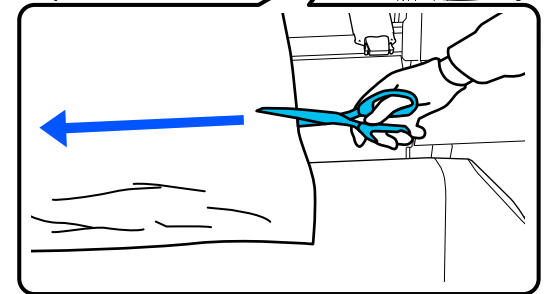
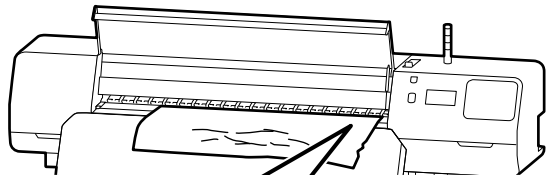
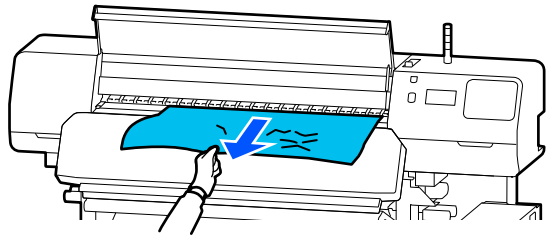
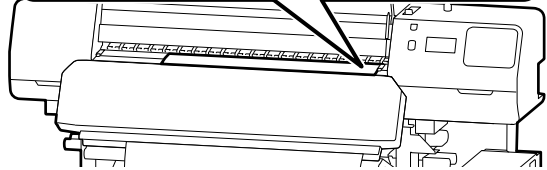
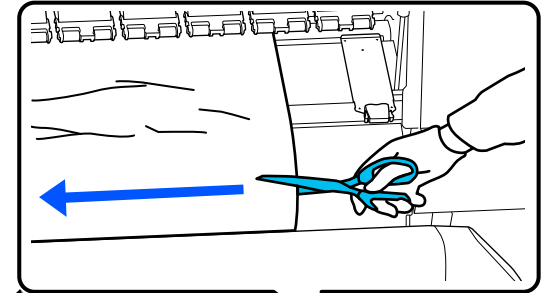

**Problem Solver**

**7** Take up the cut media.

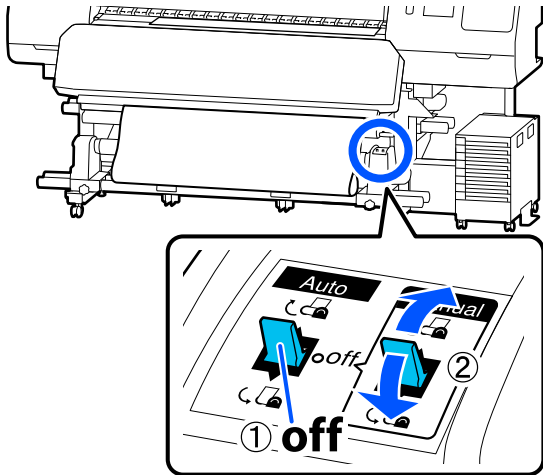

**8** Go to the back of the printer and take up the unused media.

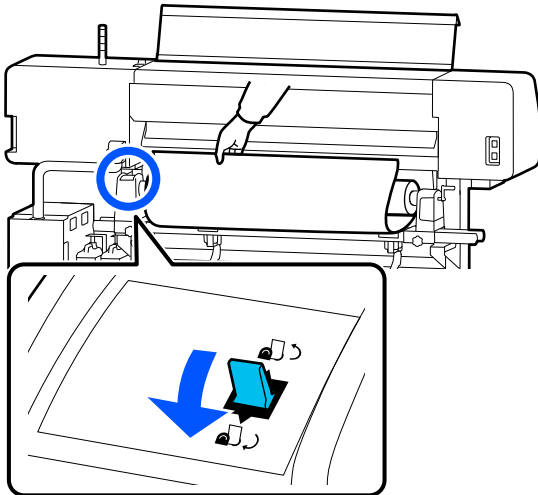

**9** Go to the front of the printer, flip the media loading lever forward, and then close the printer cover.

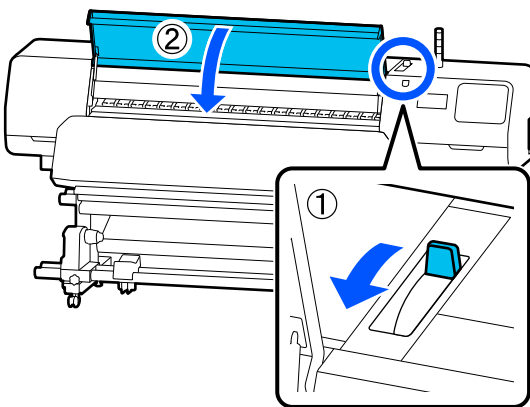

**10** Press OK.

Reload the media and resume printing.

👉 [“Loading media” on page 47](#)

**Others**

**Heater automatically turns Off**

- The pre-heater, platen heater, and curing heater turn off if no print job is received for some time and no errors occur. The time until the heaters automatically switch to Off can be changed in **Heater Off Timer** in the setup menu. 👉 [“General Settings menu” on page 106](#)

**The control panel display keeps turning off.**

- **Is the printer in sleep mode?**  
When no operations are performed on the printer for the time set in **Sleep Timer** in the setup menu, the printer enters sleep mode. The time before entering sleep mode can be changed in the General Settings menu.  
👉 [“General Settings menu” on page 106](#)  
The heaters return from sleep mode when a print job is received, the media loading lever is used, or another operation involving printer hardware is performed.

**Forgotten password for network setup protection**

- **Contact your dealer or Epson Support.**

**The red light is on inside the printer.**

- **This is not a failure.**  
The red light is a light inside the printer.

---

# Appendix

---

## Options and Consumable Products

For the latest information, see the Epson Web site. (as of June, 2020)

Epson recommends the use of genuine Ink Supply Units. Epson cannot guarantee the quality or reliability of nongenuine ink. The use of non-genuine ink may cause damage that is not covered by Epson's warranties, and under certain circumstances, may cause erratic printer behavior.

Information about non-genuine ink levels may not be displayed, and use of non-genuine ink is recorded for possible use in service support.

---

## Ink Supply Unit

### SC-R5000 Series

Printer model	Product		Part number
SC-R5000	Ink Supply Unit	Black	T48F1
		Cyan	T48F2
		Magenta	T48F3
		Yellow	T48F4
		Light Cyan	T48F5
		Light Magenta	T48F6
		Optimizer	T48F7
		Maintenance Liquid	T48F8
SC-R5010	Ink Supply Unit	Black	T48G1
		Cyan	T48G2
		Magenta	T48G3
		Yellow	T48G4
		Light Cyan	T48G5
		Light Magenta	T48G6
		Optimizer	T48G7
		Maintenance Liquid	T48G8



## Appendix

Printer model	Product		Part number
SC-R5030	Ink Supply Unit	Black	T48D1
		Cyan	T48D2
		Magenta	T48D3
		Yellow	T48D4
		Light Cyan	T48D5
		Light Magenta	T48D6
		Optimizer	T48D7
		Maintenance Liquid	T48D8
SC-R5040	Ink Supply Unit	Black	T48H1
		Cyan	T48H2
		Magenta	T48H3
		Yellow	T48H4
		Light Cyan	T48H5
		Light Magenta	T48H6
		Optimizer	T48H7
		Maintenance Liquid	T48H8
SC-R5070	Ink Supply Unit	Black	T48E120
		Cyan	T48E220
		Magenta	T48E320
		Yellow	T48E420
		Light Cyan	T48E520
		Light Magenta	T48E620
		Optimizer	T48E720
		Maintenance Liquid	T48E820

**Appendix**

Printer model	Product		Part number
SC-R5080	Ink Supply Unit	Black	T48K1
		Cyan	T48K2
		Magenta	T48K3
		Yellow	T48K4
		Light Cyan	T48K5
		Light Magenta	T48K6
		Optimizer	T48K7
		Maintenance Liquid	T48K8

**SC-R5000L Series**

Each set contains two of the same color.

Printer model	Product		Part number
SC-R5000L	Ink Supply Unit	Black	T45U1
		Cyan	T45U2
		Magenta	T45U3
		Yellow	T45U4
		Light Cyan	T45U5
		Light Magenta	T45U6
		Optimizer	T45U7
		Maintenance Liquid	T45U8
SC-R5010L	Ink Supply Unit	Black	T45V1
		Cyan	T45V2
		Magenta	T45V3
		Yellow	T45V4
		Light Cyan	T45V5
		Light Magenta	T45V6
		Optimizer	T45V7
		Maintenance Liquid	T45V8

## Appendix

Printer model	Product		Part number
SC-R5030L	Ink Supply Unit	Black	T45R1
		Cyan	T45R2
		Magenta	T45R3
		Yellow	T45R4
		Light Cyan	T45R5
		Light Magenta	T45R6
		Optimizer	T45R7
		Maintenance Liquid	T45R8
SC-R5040L	Ink Supply Unit	Black	T45W1
		Cyan	T45W2
		Magenta	T45W3
		Yellow	T45W4
		Light Cyan	T45W5
		Light Magenta	T45W6
		Optimizer	T45W7
		Maintenance Liquid	T45W8
SC-R5070L	Ink Supply Unit	Black	T45S120
		Cyan	T45S220
		Magenta	T45S320
		Yellow	T45S420
		Light Cyan	T45S520
		Light Magenta	T45S620
		Optimizer	T45S720
		Maintenance Liquid	T45S820

## Appendix

Printer model	Product	Part number	
SC-R5080L	Ink Supply Unit	Black	T46A1
		Cyan	T46A2
		Magenta	T46A3
		Yellow	T46A4
		Light Cyan	T46A5
		Light Magenta	T46A6
		Optimizer	T46A7
		Maintenance Liquid	T46A8

## Maintenance Items

Product	Part number	Explanation
Cleaning Ink Supply Unit (except for SC-R5080/SC-R5080L)	T45X1*1	Use when performing Keeping Preparation.
Cleaning Ink Supply Unit (for SC-R5080/SC-R5080L)	T45X2	
Wiper Unit (except for SC-R5080/SC-R5080L)	C13S210100	The following consumable items are included in one maintenance set.
Wiper Unit (for SC-R5080/SC-R5080L)	C13S210101	<input type="checkbox"/> Wiper unit (x1) <input type="checkbox"/> Gloves (x2)
Cleaning Kit (except for SC-R5080/SC-R5080L)	C13S210103	Identical to the Cleaning Kit supplied with the printer.
Cleaning Kit (for SC-R5080/SC-R5080L)	C13S210104	
Waste Ink Bottle (except for SC-R5080/SC-R5080L)	C13S210071	Identical to the Waste Ink Bottle supplied with the printer. Contains one bottle.
Waste Ink Bottle (for SC-R5080/SC-R5080L)	C13S210072	
Media Cleaner Brush	C12C936031	Identical to the Media Cleaner Brush supplied with the printer.
Media Edge Plate	C12C935321	Identical to the Media Edge Plate supplied with the printer.
Thermal Sheet	C12C936551	Identical to the Thermal Sheet supplied with the printer.
Cleaning Stick	C13S090013	Identical to the cleaning kit items supplied with the printer.

**Appendix**

<b>Product</b>	<b>Part number</b>	<b>Explanation</b>
Clean Room Wiper* <sup>2</sup>	C13S090016	Identical to the Clean Room Wiper supplied with the printer.

\*1 North American and Latin American users: Please use part number C13T45X100 when ordering.

\*2 Not available for purchase in some countries and regions. We recommend BEMCOT M-3II from the Asahi Kasei Corporation when purchasing commercial products.

## Supported Media

The following media can be used with the printer.

Print quality is greatly affected by the type and quality of media used. Choose a media suited to the task at hand. For information on use, refer to the documentation supplied with the media or contact the manufacturer. Before buying media in large quantities, try printing on a smaller sample and check the results.



**Important:**

*Do not use media that is wrinkled, scuffed, torn, or dirty.*

### Roll media

Roll core size	2 or 3 inch
Roll outer diameter	Media Feeding Unit: Up to 250 mm (9.8 in.) Auto take-up reel unit: Up to 200 mm (7.87 in.)
Media width	300 to 1,626 mm (64 inches)
Media thickness	Maximum 1 mm (0.039 inches)
Roll weight	Maximum 45 kg (99 lbs)

## Moving and Transporting the Printer

This section describes how to move and transport the product.

### Moving the Printer

This section assumes that the product is being moved to another location on the same floor without traversing stairs, ramps, or lifts. See below for information on moving the printer between floors or to another building.

 [“Transport” on page 138](#)



**Warning:**

- To prevent ground leak accidents, connect to a grounded (earthed) outlet. Connecting to anything other than a grounded outlet could result in electric shock or fire.*
- Use only the type of power source indicated on the printer's label. An electric shock or fire could occur.*
- Do not connect the power cable to a power strip or multi plug. An electric shock or fire could occur. Connect the power cable directly to an outlet for domestic use.*



**Caution:**

*Do not tilt the product more than 10 degrees forward or back while moving it. Failure to observe this precaution could result in the printer falling over, causing accidents.*

Appendix

**! Important:**

- ❑ Do not remove the ink supply units. Failure to observe this precaution could cause the print head nozzles to dry out.
- ❑ Be sure to move the printer under the following conditions.
  - ❑ Do not separate the ink unit and the printer. (Transport the printer with the ink tube connector connected to the back of the printer and the connector locked.)
  - ❑ Make sure the ink unit wire is fastened.

**Getting Ready**

- 1** Confirm that the printer is off.
- 2** Remove the Waste Ink Bottle.
  - 🔗 “Replacing the Waste Ink Bottle” on page 90
- 3** Disconnect the power cable and all other cables from the printer.
 

Also, remove the following from the ink unit.

  - ❑ Power cable and connection cable
  - ❑ Overturn-prevention plate (for both sides)
- 4** Remove media from the Media Feeding Unit and the Auto Take-up Reel Unit.
- 5** Unlock the two casters on the front of the printer's legs.
 

Unlock all four casters on the ink unit.

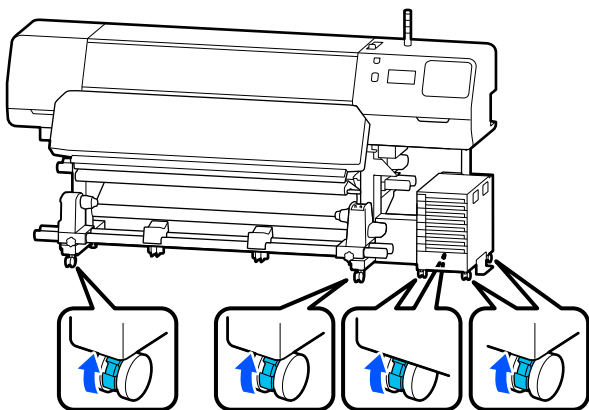

**! Important:**

When performing level adjustment using the levelers, make sure you raise the levelers above the casters before trying to move the printer. Moving the printer without raising the levelers could cause a malfunction. You need the spanner supplied to adjust the levelers.

- (1) Loosen the nut on the top of the levelers.
- (2) Turn the nut on the bottom counter-clockwise.
- (3) Check that it is above the casters.

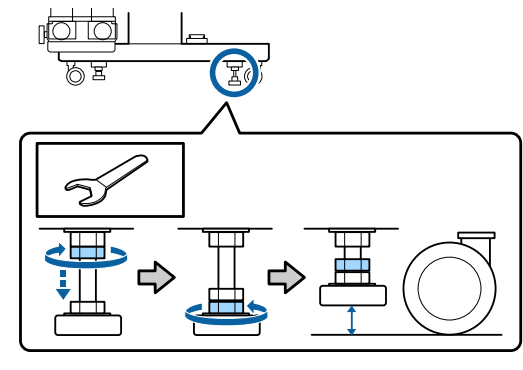

- 6** Move the printer.
 

Use three people to move the printer; one on each side of the printer and one for the ink unit. Also, move so that the printer goes first in the direction you are going.

**! Important:**

Use the casters on the dedicated printer stand to move the printer indoors a short distance over a level floor. They can not be used for transport.

**When moving through a narrow space**

You can move through doors and so on that are at least 1050 mm (41.3 in.) wide. If you remove the curing heater, you can pass through gaps that are at least 900 mm (35.4 in.) wide.

Follow the steps below to remove the curing heater.

Appendix

**!** Important:

- ❑ Make sure you use two people when removing and carrying the curing heater.
- ❑ When carrying the curing heater, make sure your hands are positioned as shown in the figure.

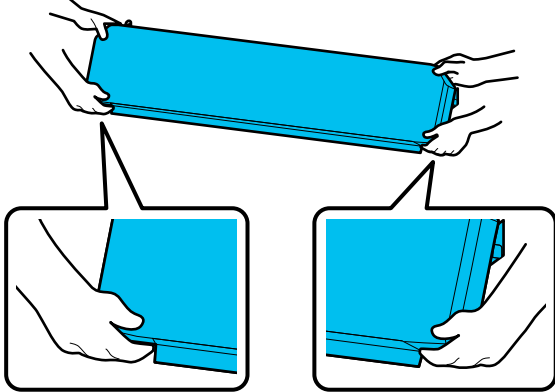

**1** Turn off the printer and unplug both of the power cables.

**2** Unplug both power cables from the curing heater.

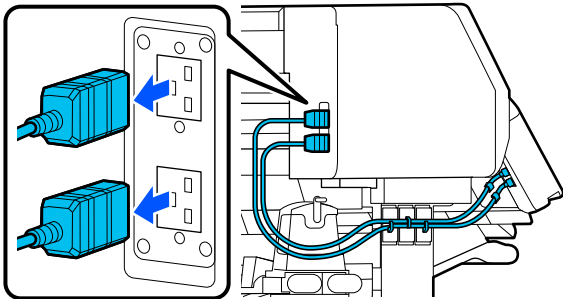

**3** Open the printer cover and the maintenance covers on the left and right.

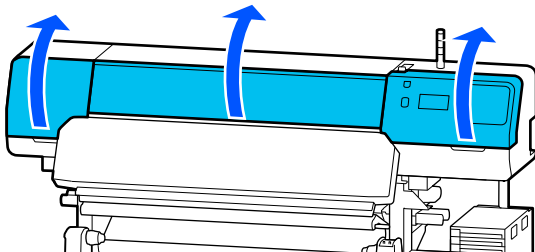

**4** Open the covers on the left and right of the curing heater.

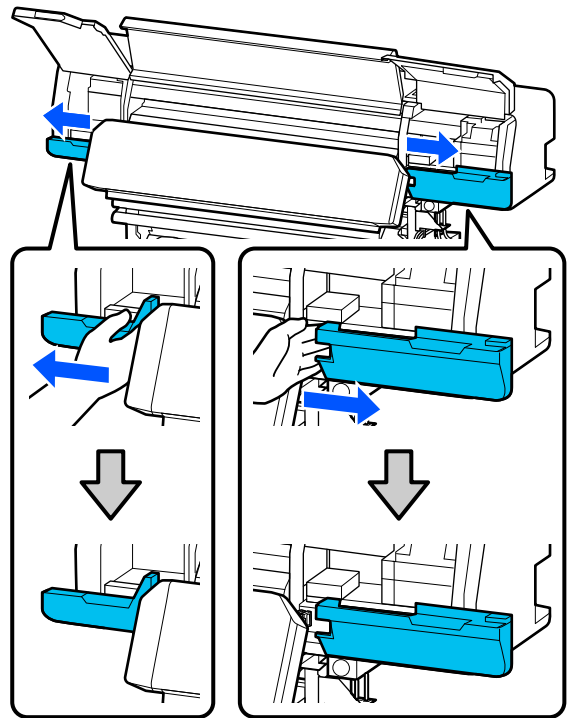

**5** Remove the connector for the curing heater.

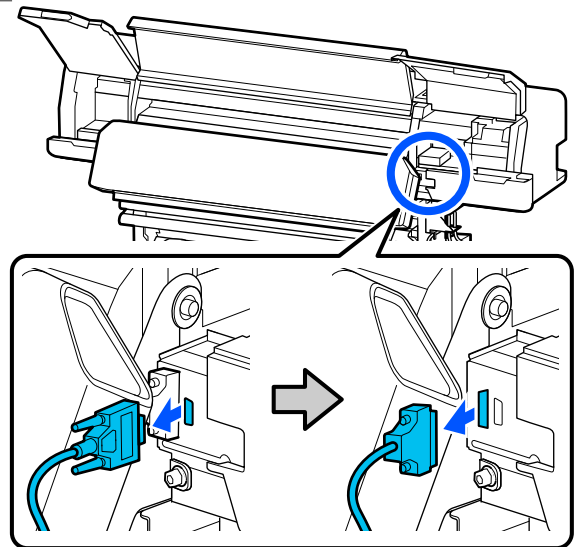



Appendix

**6** Remove the screws.

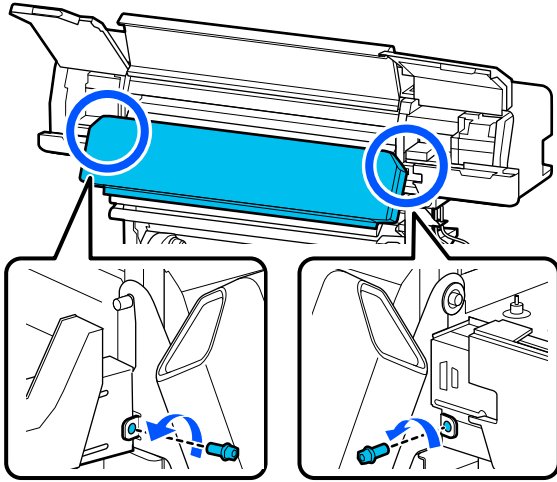

**7** Remove the curing heater.

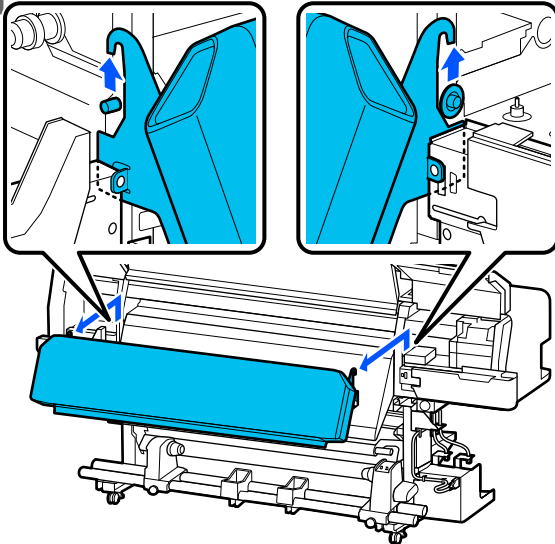

**8** Close the covers on the left and right.

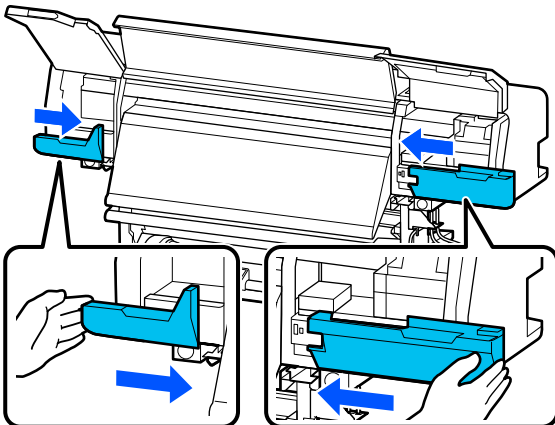

**9** Close the printer cover and the maintenance covers on the left and right.

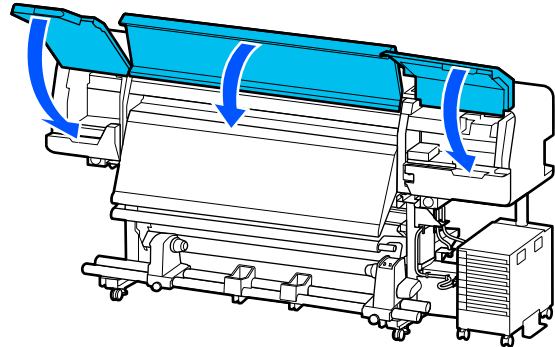

**Post-Move Setup**

After moving the printer, follow the steps below to ready it for use.

**1** If you have removed the curing heater, be sure to see the following to install it correctly.

Check that the new location is appropriate, and attach the parts that were removed.

Regions other than North America and Latin America :  *Setup Guide* (booklet)

If you do not have the *Setup Guide* on hand, select and refer to the model of your printer from <http://epson.sn>.

North American and Latin American users:  
Contact your dealer for product installation. The product must be installed by an authorized dealer. Damage to the product from unauthorized installation will not be covered by your Epson warranty.

**2** Plug the power plug into an outlet with a grounding (earth) connector, and then turn on the power.

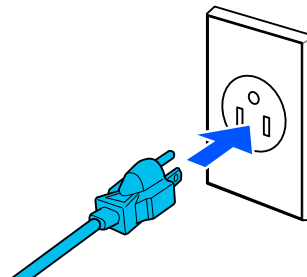

## Appendix

**Important:**

*The shape of the plug varies with the region or country of sale. Use the supplied power cable only.*

**3**

Perform a Print Head Nozzle Check to check for clogged nozzles.

 [“How to Print a Nozzle Check Pattern” on page 95](#)

**4**

Execute **Print Adjustments** in the Settings menu.

 [“Optimizing Media Settings \(Automatic Adjustment\)” on page 61](#)

---

## Transport

Before transporting the printer, contact your dealer or Epson Support.

 [“Where To Get Help” on page 145](#)

## Appendix

## Print Lengths by Pass Number and Creating a Job

---

**Table of Print Lengths by Pass Number**

Number of Passes	Media width	
	54 Inches or Less	Up to 64 Inches
1 pass	253.7 m (832.3 ft.)	228.8 m (750.6 ft.)
4 pass	70.4 m (230.9 ft.)	62.7 m (205.7 ft.)
5 pass	56 m (183.7 ft.)	49.9 m (163.7 ft.)
6 pass	43.1 m (141.4 ft.)	38.5 m (126.3 ft.)
9 pass	31 m (101.7 ft.)	27.7 m (90.9 ft.)
14 pass	19.5 m (64 ft.)	17.4 m (57.1 ft.)
20 pass	13.5 m (44.3 ft.)	12.1 m (39.7 ft.)
26 pass	10.7 m (35.1 ft.)	9.5 m (31.1 ft.)
35 pass	7.8 m (25.6 ft.)	6.9 m (22.6 ft.)

---

### Creating a job

Take one of the following actions if the print length exceeds three hours.

- If the result of nesting jobs in RIP or Step and Repeat is over three hours, divide the nested jobs into multiple jobs within the three hour time window, or set the Layout Area Size in Step and Repeat to a print length within the table above.
- If a single job takes more than three hours, you can split the image into multiple jobs by using the cropping function.
- If a single job takes more than three hours but you do not want to split the image, print in a faster print mode to finish printing within three hours.

## Appendix

# System Requirements

This software can be used in the following environments. (As of June 2020)

The supported operating systems may change.

For the latest information, see the Epson Web site.

---

## Epson Edge Dashboard

 **Important:**

*Make sure the computer on which the Epson Edge Dashboard is installed meets the following requirements. If these requirements are not met, the software cannot monitor the printer correctly.*

- Disable your computer's hibernate function.*
- Disable the sleep function so that the computer does not enter sleep status.*

### Windows

Operating systems	Windows 7 SP1 / Windows 7 x64 SP1 Windows 8 / Windows 8 x64 Windows 8.1 / Windows 8.1 x64 Windows 10 / Windows 10 x64
CPU	Multi-core processor (3.0 GHz or better recommended)
Free memory	4 GB or more
Hard disk (free space during installation)	2 GB or more
Display resolution	1280 × 1024 or higher
Communication interface	High Speed USB Ethernet 1000Base-T
Browser	Internet Explorer 11 Microsoft Edge

### Mac

Operating systems	Mac OS X 10.7 Lion or later
CPU	Multi-core processor (3.0 GHz or better recommended)
Free memory	4 GB or more
Hard disk (free space during installation)	2 GB or more

## Appendix

Display resolution	1280 × 1024 or higher
Communication interface	High Speed USB Ethernet 1000Base-T
Browser	Safari 6 or later

### Linux

Distribution	Debian 8.6 64bit (MATE desktop environment only) or later
CPU	Multi-core processor (3.0 GHz or better recommended)
Free memory	4 GB or more
Hard disk (free space during installation)	2 GB or more
Display resolution	1280 × 1024 or higher
Communication interface	High Speed USB Ethernet 1000Base-T
Browser	Mozilla Firefox 45 (ESR) or later

---

## Epson Edge Print

Operating system	Windows 7 x64 SP1 Windows 8 x64 Windows 8.1 x64 Windows 10 x64
CPU	Multi-core processor (3.0 GHz or better recommended)
Available memory space	8 GB or more
Hard disk (Available volume to install)	50 GB or more
Display resolution	1280 × 1024 or higher
Communication interface	High Speed USB Ethernet 100Base-TX/1000Base-T

The computer on which this software is installed is expected to be able to simultaneously use other applications, such as Adobe Illustrator. So, we recommend using a computer with the highest specifications available.

In addition, the data that this software handles is normally several GB, and could reach several tens of GB for long high-quality print jobs. Because of this, we recommend a computer that has a hard disk with sufficient surplus available memory capacity.

---

## Web Config

The following is a list of supported browsers.

## Appendix

Internet Explorer 11, Microsoft Edge, Firefox\*, Chrome\*, Safari\*

\*Make sure you are using the latest version.

Appendix

# Specifications Table

Printer Specifications	
Printing method	On-demand ink jet
Nozzle configuration	
Except for LM and LC	400 nozzles x 2 x 2 rows x 5 colors (Black, Cyan, Magenta, Yellow, Optimizer)
LM, LC	400 nozzles x 2 x 1 rows x 2 colors (Light Magenta, Light Cyan)
Resolution (maximum)	1200 x 2400 dpi Print resolution equivalent to 600 x 600 x 8 Half Tone layers
Control code	ESC/P raster (undisclosed command)
Media feed method	Friction feed method
Built-in memory	2 GB
Interface	Hi-Speed USB-Compatible with the USB 2.0 Specification. 100Base-TX/1000Base-T*1
Rated voltage (input)	
#1, #2	AC200-240 V
Ink unit*2	AC100-240 V
Rated voltage (output)	
#3	AC200-240 V
Rated frequency (input)	
#1, #2	50/60 Hz
Ink Unit	50/60 Hz
Rated frequency (output)	
#3	50/60 Hz
Rated current (input)	
#1, #2	16 A
Ink Unit	1.4 A
Rated current (output)	

Printer Specifications	
#3	1.4 A
Power consumption	
SC-R5000 Series (total for numbers #1 and #2)	Printing: Approx. 4.6 kW Sleep mode: Approx. 44.0 W Power off: Approx. 1.0 W
SC-R5000L Series (total for numbers #1 and #2)	Printing: Approx. 4.6 kW Sleep mode: Approx. 46.0 W Power off: Approx. 1.1 W
Temperature and humidity (without condensation)	
Recommended	20 to 25°C (68 to 77°F), 40 to 60%
In use	15 to 30°C (59 to 86°F), 20 to 80%
During storage (before unpacking)	-20 to 60°C (-4 to 140°F) (within 120 hours at 60°C [140°F], within a month at 40°C [104°F]), 5 to 85%
During storage*3 (after unpacking)	-20 to 40°C (-4 to 104°F) (within a month at 40°C [104°F]), 5 to 85%
Temperature and humidity range Gray area: When in use Diagonal line area: Recommended (%)	
<p>The graph plots humidity (%) on the y-axis (10 to 90) against temperature (°C) on the x-axis (10 to 40). A gray shaded region indicates the 'When in use' range, which is approximately 15°C to 30°C and 20% to 80% humidity. A diagonal line area within this gray region indicates the 'Recommended' range, which is approximately 20°C to 27°C and 40% to 60% humidity.</p>	
Dimension	
Storage dimensions	2949 (W) x 1045 (D) x 1605 (H) mm (116.1 [W] x 41.1 [D] x 63.2 [H] inches)
Maximum dimensions	2949 (W) x 1045 (D) x 1774 (H) mm (116.1 [W] x 41.1 [D] x 69.5 [H] inches)
Weight*4	

Appendix

Printer Specifications	
SC-R5000 Series	Approx. 425 kg (937 lbs)
SC-R5000L Series	Approx. 449 kg (990 lbs)

- \*1 Use a shielded twisted pair cable (category 5e or higher).
- \*2 Make sure you connect the power cable for the ink unit to the printer's AC outlet (# 3).
- \*3 When storing the printer in an environment below -15°C, make sure you execute **Keeping Preparation** in the settings menu. If the printer is stored without executing this procedure, the print head could be damaged.

 “Long-term Storage (Pre-storage Maintenance)” on page 97

- \*4 Not including ink supply units

Ink Specifications	
Type	Dedicated ink supply unit
Types of ink	Resin ink
Use by date	See the date printed on the ink supply unit packaging or the ink supply unit.
Print quality guarantee expiry	1 year (from the date on the ink unit)
Storage temperature	Uninstalled: -20 to 40°C (-4 to 104°F) (within 4 days at -20°C [-4°F], within a month at 40°C [104°F])  When ink unit is installed: -20 to 40°C (-4 to 104°F) (within 4 days at -20°C [-4°F], within a month at 40°C [104°F])  Transporting: -20 to 60°C (-4 to 140°F) (within 4 days at -20°C [-4°F], within a month at 40°C [104°F], within 3 days at 60°C [140°F])
Dimensions	180 (W) × 410 (D) × 30 (H) mm (7.1 [W] × 16.1 [D] × 1.2 [H] inches)
Capacity	1500 ml (50.7 fl. oz)



**Important:**

Use the printer at an altitude of 2000 m (6562 ft.) or less.



**Warning:**

This is a class A product. In a domestic environment this product may cause radio interference in which case the user may be required to take adequate measures.

**Information of EU declaration of conformity**

The full text of the EU declaration of conformity of this equipment is available at the following internet address.

<https://www.epson.eu/conformity>



---

## Where To Get Help

---

### Technical Support Web Site

Epson's Technical Support Web Site provides help with problems that cannot be solved using the troubleshooting information in your product documentation. If you have a Web browser and can connect to the Internet, access the site at:

<https://support.epson.net/>

If you need the latest drivers, FAQs, manuals, or other downloadables, access the site at:

<https://www.epson.com>

Then, select the support section of your local Epson Web site.

## Contacting Epson Support

---

### Before Contacting Epson

If your Epson product is not operating properly and you cannot solve the problem using the troubleshooting information in your product documentation, contact Epson support services for assistance. If Epson support for your area is not listed below, contact the dealer where you purchased your product.

Epson support will be able to help you much more quickly if you give them the following information:

- Product serial number  
(The serial number label is usually on the back of the product.)
- Product model
- Product software version  
(Click **About**, **Version Info**, or similar button in the product software.)
- Brand and model of your computer
- Your computer operating system name and version
- Names and versions of the software applications you normally use with your product

---

### Help for Users in North America

Visit <https://www.epson.com/support> (U.S.) or <http://www.epson.ca/support> (Canada) and search for your product to download software and utilities, view manuals, get FAQs and troubleshooting advice, or contact Epson.

Epson provides technical support and information on the installation, configuration, and operation of professional printing products through the Epson Preferred Limited Warranty Plan. Dial (888) 377-6611, 6 AM to 6 PM, Pacific Time, Monday through Friday. Days and hours of support are subject to change without notice. Before you call, make sure you have your printer serial number and proof of purchase.

## Where To Get Help

**Note:**

- If you experience difficulty with the toll-free line, call (562) 276-1305.
- For help using any other software on your system, see the documentation for that software for technical support

### Purchase Supplies and Accessories

You can purchase genuine Epson ink, paper, and accessories from an Epson authorized reseller. To find the nearest reseller, visit <http://proimaging.epson.com> (U.S.) or <http://proimaging.epson.ca> (Canada), select your product series and product, and click the **Where to Buy** button. Or call 800-GO-EPSON (800-463-7766) in the U.S. or 800-807-7766 in Canada.

### Help for Users in Latin America

If you need additional help with your Epson product, contact Epson.

Epson provides these technical support services:

#### Internet Support

Visit Epson's support website at <http://epson.com.jm/Support/> (Caribbean), <http://www.epson.com.br/suporte> (Brazil), or <http://www.latin.epson.com/soporte> (other regions) for solutions to common problems. You can download drivers and documentation, get FAQs and troubleshooting advice, or e-mail Epson with your questions.

#### Speak to a Support Representative

Before you call Epson for support, please have the following information ready:

- Product name
- Product serial number (located on a label on the product)
- Proof of purchase (such as a store receipt) and date of purchase
- Computer configuration
- Description of the problem

Then call:

Country	Telephone
Argentina	(54 11) 5167-0300 0800-288-37766
Bolivia*	800-100-116
Brazil	0800-007-5000
Chile	(56 2) 2484-3400
Colombia	Bogota: (57 1) 592-2200 Other cities: 018000-915235
Costa Rica	800-377-6627
Dominican Republic*	1-888-760-0068
Ecuador*	1-800-000-044
El Salvador*	800-6570
Guatemala*	1-800-835-0358
Mexico	Mexico City: (52 55) 1323-2052 Other cities: 01-800-087-1080
Nicaragua*	00-1-800-226-0368
Panama*	00-800-052-1376
Paraguay	009-800-521-0019
Peru	Lima: (51 1) 418-0210 Other cities: 0800-10-126
Uruguay	00040-5210067
Venezuela	(58 212) 240-1111

\* Contact your local phone company to call this toll-free number from a mobile phone.

If your country does not appear in the list, contact the sales office in the nearest country. Toll or long distance charges may apply.

## Where To Get Help

### Purchase Supplies and Accessories

You can purchase genuine Epson ink, paper, and accessories from an Epson authorized reseller. To find the nearest reseller, visit <http://www.epson.com.jm> (Caribbean), <http://www.epson.com.br> (Brazil), or <http://www.latin.epson.com> (other regions) or call your nearest Epson sales office.

### Help for Users in Europe

Check your **Pan-European Warranty Document** for information on how to contact Epson support.

### Help for Users in Taiwan

Contacts for information, support, and services are:

**World Wide Web (<https://www.epson.com.tw>)**

Information on product specifications, drivers for download, and products enquiry are available.

### Epson HelpDesk (Phone: +0800212873)

Our HelpDesk team can help you with the following over the phone:

- Sales enquiries and product information
- Product usage questions or problems
- Enquiries on repair service and warranty

### Repair service center:

Telephone number	Fax number	Address
02-23416969	02-23417070	No.20, Beiping E. Rd., Zhongzheng Dist., Taipei City 100, Taiwan
02-27491234	02-27495955	1F., No.16, Sec. 5, Nanjing E. Rd., Songshan Dist., Taipei City 105, Taiwan

Telephone number	Fax number	Address
02-32340688	02-32340699	No.1, Ln. 359, Sec. 2, Zhongshan Rd., Zhonghe City, Taipei County 235, Taiwan
039-605007	039-600969	No.342-1, Guangrong Rd., Luodong Township, Yilan County 265, Taiwan
038-312966	038-312977	No.87, Guolian 2nd Rd., Hualien City, Hualien County 970, Taiwan
03-4393119	03-4396589	5F., No.2, Nandong Rd., Pingzhen City, Taoyuan County 32455, Taiwan (R.O.C.)
03-5325077	03-5320092	1F., No.9, Ln. 379, Sec. 1, Jingguo Rd., North Dist., Hsinchu City 300, Taiwan
04-23011502	04-23011503	3F., No.30, Dahe Rd., West Dist., Taichung City 40341, Taiwan (R.O.C.)
04-23805000	04-23806000	No.530, Sec. 4, Henan Rd., Nantun Dist., Taichung City 408, Taiwan
05-2784222	05-2784555	No.463, Zhongxiao Rd., East Dist., Chiayi City 600, Taiwan
06-2221666	06-2112555	No.141, Gongyuan N. Rd., North Dist., Tainan City 704, Taiwan
07-5520918	07-5540926	1F., No.337, Minghua Rd., Gushan Dist., Kaohsiung City 804, Taiwan
07-3222445	07-3218085	No.51, Shandong St., Sanmin Dist., Kaohsiung City 807, Taiwan
08-7344771	08-7344802	1F., No.113, Shengli Rd., Pingtung City, Pingtung County 900, Taiwan

## Where To Get Help

### Help for Users in Australia/New Zealand

Epson Australia/New Zealand wishes to provide you with a high level of customer service. In addition to your product documentation, we provide the following sources for obtaining information:

#### Your Dealer

Don't forget that your dealer can often help identify and resolve problems. The dealer should always be the first call for advice on problems; they can often solve problems quickly and easily as well as give advice on the next step to take.

#### Internet URL

##### Australia

<https://www.epson.com.au>

##### New Zealand

<https://www.epson.co.nz>

Access the Epson Australia/New Zealand World Wide Web pages.

The site provides a download area for drivers, Epson contact points, new product information and technical support (e-mail).

#### Epson Helpdesk

Epson Helpdesk is provided as a final backup to make sure our clients have access to advice. Operators on the Helpdesk can aid you in installing, configuring and operating your Epson product. Our Pre-sales Helpdesk staff can provide literature on new Epson products and advise where the nearest dealer or service agent is located. Many types of queries are answered here.

The Helpdesk numbers are:

Australia	Phone:	1300 361 054
	Fax:	(02) 8899 3789
New Zealand	Phone:	0800 237 766

We encourage you to have all the relevant information on hand when you ring. The more information you prepare, the faster we can help solve the problem. This information includes your Epson product documentation, type of computer, operating system, application programs, and any information you feel is required.

### Help for Users in Singapore

Sources of information, support, and services available from Epson Singapore are:

#### World Wide Web

<https://www.epson.com.sg>

Information on product specifications, drivers for download, Frequently Asked Questions (FAQ), Sales Enquiries, and Technical Support via e-mail are available.

#### Epson HelpDesk (Toll Free: 800-120-5564)

Our HelpDesk team can help you with the following over the phone:

- Sales enquiries and product information
- Product usage questions or problems
- Enquiries on repair service and warranty

### Help for Users in Thailand

Contacts for information, support, and services are:

#### World Wide Web

<https://www.epson.co.th>

Information on product specifications, drivers for download, Frequently Asked Questions (FAQ), and e-mail are available.

#### Epson Hotline (Phone: (66)2685-9899)

Our Hotline team can help you with the following over the phone:

## Where To Get Help

- Sales enquiries and product information
- Product usage questions or problems
- Enquiries on repair service and warranty

---

### Help for Users in Vietnam

Contacts for information, support, and services are:

Epson Hotline (Phone): +84 28 3925 5545

Service Center: 68 Nam Ky Khoi Nghia  
Street, Nguyen Thai Binh  
Ward, District 1, Ho Chi  
Minh City, Vietnam

---

### Help for Users in Indonesia

Contacts for information, support, and services are:

#### World Wide Web

(<https://www.epson.co.id>)

- Information on product specifications, drivers for download
- Frequently Asked Questions (FAQ), Sales Enquiries, questions through e-mail

#### Epson Hotline

- Sales enquiries and product information
- Technical support
  - Phone (62) 21-572 4350
  - Fax (62) 21-572 4357

#### Epson Service Center

Jakarta Mangga Dua Mall 3rd floor No 3A/B  
Jl. Arteri Mangga Dua,  
Jakarta

Phone/Fax: (62) 21-62301104

Bandung Lippo Center 8th floor  
Jl. Gatot Subroto No.2  
Bandung

Phone/Fax: (62) 22-7303766

Surabaya Hitech Mall It IIB No. 12  
Jl. Kusuma Bangsa 116 – 118  
Surabaya

Phone: (62) 31-5355035  
Fax: (62)31-5477837

Yogyakarta Hotel Natour Garuda  
Jl. Malioboro No. 60  
Yogyakarta

Phone: (62) 274-565478

Medan Wisma HSBC 4th floor  
Jl. Diponegoro No. 11  
Medan

Phone/Fax: (62) 61-4516173

Makassar MTC Karebosi Lt. III Kav. P7-8  
Jl. Ahmad Yani No.49  
Makassar

Phone: (62)411-350147/411-350148

---

### Help for Users in Hong Kong

To obtain technical support as well as other after-sales services, users are welcome to contact Epson Hong Kong Limited.

#### Internet Home Page

Epson Hong Kong has established a local home page in both Chinese and English on the Internet to provide users with the following information:

- Product information
- Answers to Frequently Asked Questions (FAQs)
- Latest versions of Epson product drivers

Users can access our World Wide Web home page at:

<https://www.epson.com.hk>

## Where To Get Help

### Technical Support Hotline

You can also contact our technical staff at the following telephone and fax numbers:

Phone: (852) 2827-8911

Fax: (852) 2827-4383

---

### Help for Users in Malaysia

Contacts for information, support, and services are:

#### World Wide Web

(<https://www.epson.com.my>)

- Information on product specifications, drivers for download
- Frequently Asked Questions (FAQ), Sales Enquiries, questions through e-mail

#### Epson Trading (M) Sdn. Bhd.

Head Office.

Phone: 603-56288288

Fax: 603-56288388/399

#### Epson Helpdesk

- Sales enquiries and product information (Infoline)  
Phone: 603-56288222
- Enquiries on repair services & warranty, product usage and technical support (Techline)  
Phone: 603-56288333

---

### Help for Users in India

Contacts for information, support, and services are:

### World Wide Web

(<https://www.epson.co.in>)

Information on product specifications, drivers for download, and products enquiry are available.

#### Helpline

For Service, Product info, or to order consumables - 18004250011 (9AM - 6PM) - This is a Toll-free number.

For Service (CDMA & Mobile Users) - 3900 1600 (9AM - 6PM) Prefix local STD code

---

### Help for Users in the Philippines

To obtain technical support as well as other after sales services, users are welcome to contact the Epson Philippines Corporation at the telephone and fax numbers and e-mail address below:

Trunk Line: (63-2) 706 2609

Fax: (63-2) 706 2665

Helpdesk (63-2) 706 2625  
Direct Line:

E-mail: [epchelpdesk@epc.epson.com.ph](mailto:epchelpdesk@epc.epson.com.ph)

#### World Wide Web

(<https://www.epson.com.ph>)

Information on product specifications, drivers for download, Frequently Asked Questions (FAQ), and E-mail Enquiries are available.

#### Toll-Free No. 1800-1069-EPSON(37766)

Our Hotline team can help you with the following over the phone:

- Sales enquiries and product information
- Product usage questions or problems
- Enquiries on repair service and warranty